



0000013825

31EX

LEGAL

RECEIVED

2004 AUG 30 1 A 10: 05

AZ CORP COMMISSION
DOCUMENT CONTROL



TO: Docket Control
FROM: Ernest G. Johnson
Director
Utilities Division

DATE: August 30, 2004

RE: STAFF REPORT FOR TONTO HILLS UTILITY COMPANY'S APPLICATION
FOR A PERMANENT RATE INCREASE (DOCKET NO. W-02483A-04-0242)

Attached is the Staff Report for Tonto Hills Utility Company. Staff recommends approval of its rates and charges as shown on Schedule 4 of this report.

EGJ:JRM:rdp

Originator: Jamie Ryan Moe

Attachment: Original and sixteen copies

RECEIVED

AUG 30 2004

LEGAL DIV.
ARIZ. CORPORATION COMMISSION

Arizona Corporation Commission
DOCKETED

SEP 29 2004

DOCKETED BY

AR

AZ CORP COMMISSION
DOCUMENT CONTROL

2004 SEP 29 P 12: 43

RECEIVED

Service List for: Tonto Hills Utility Company
Docket No. W-02483A-04-0242

Mr. Leonard L. Dueker, Company Consultant
President of DCI Incorporated
815 South Rochester
Mesa, Arizona 85206

Mr. Donald Unthank, President
Tonto Hills Utility Company
11802 East Blue Wash Road
Cave Creek, Arizona 85331

Jennifer Amundson, Secretary
Tonto Hills Board of Directors
42033 North Old Mine Road
Cave Creek, Arizona 85331

Christopher C. Kempley, Esq., Chief Counsel
Legal Division
Arizona Corporation Commission
1200 West Washington Street
Phoenix, Arizona 85007

Ernest G. Johnson, Esq., Director
Utilities Division
Arizona Corporation Commission
1200 West Washington Street
Phoenix, Arizona 85007

Lyn Farmer, Esq., Chief Administrative Law Judge
Hearing Division
Arizona Corporation Commission
1200 West Washington Street
Phoenix, Arizona 85007

**STAFF REPORT
UTILITIES DIVISION
ARIZONA CORPORATION COMMISSION**

TONTO HILLS UTILITY COMPANY

DOCKET NO. W-02483A-04-0242

APPLICATION FOR A PERMANENT RATE INCREASE

AUGUST 2004

STAFF ACKNOWLEDGMENT

The Staff Report for Tonto Hills Utility Company, Docket No. W-02483A-04-0242, was the responsibility of the Staff members listed below. Jamie R. Moe was responsible for the review and analysis of the Company's application, recommended revenue requirements, rate base and rate design. John A. Chelus was responsible for the engineering and technical analysis. Alfonso Amezcua was responsible for reviewing the Commission's records on the Company, determining compliance with Commission policies/rules and reviewing customer complaints filed with the Commission.

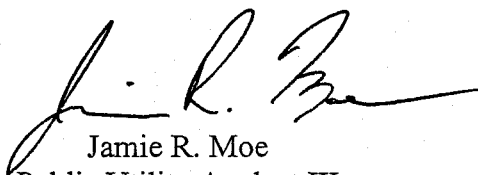

Jamie R. Moe
Public Utility Analyst III

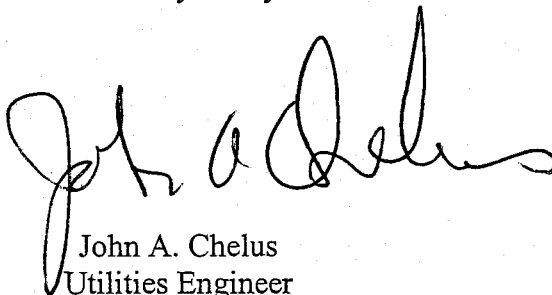

John A. Chelus
Utilities Engineer

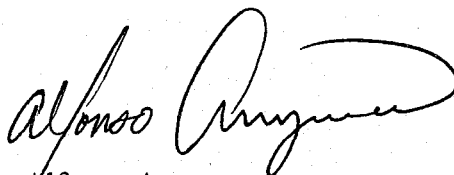

Alfonso Amezcua
Public Utilities Consumer Analyst I

EXECUTIVE SUMMARY

Tonto Hills Utility Company ("Tonto Hills" or "Company") is an "S" corporation that serves approximately 116 customers and is located in Maricopa County where it abuts the far northeast corner of Scottsdale on Cave Creek Road where it enters the Tonto National Forest. There are lots for approximately 220 total customers, of which 200 are residential and the remaining 20 would be commercial. All current customers are residential. Its current rates and charges were approved in Decision No. 61109, dated August 28, 1998.

The Company's proposed rates, as filed, produce total operating revenues of \$194,617 and operating income of \$67,575, for an operating margin of 34.72 percent and an 11.20 percent rate of return on an Original Cost Rate Base ("OCRB") of \$603,390. The Company's proposed rates would increase the typical residential bill, with a median usage of 5,261 gallons, by \$50.00, or 66.0 percent, from \$75.77 to \$125.77 (See Schedule 5, Page 1).

Staff recommends rates that produce total operating revenues of \$126,769 and operating income of \$39,856, for an operating margin of 31.44 percent and an 8.58 percent rate of return on an OCRB of \$464,733. Staff's recommended rates would increase the typical residential bill, with a median usage of 5,261 gallons, by \$4.29, or 5.7 percent, from \$75.77 to \$80.06. Staff's adjustments to remove "not used and useful" plant from rate base and to reduce rate case expense are the two primary reasons Staff's recommended revenue requirement is lower than the Company's.

The Company filed its rate case due to the extensive effort and process required to obtain an allocation of 71 acre-feet of water from the Central Arizona Project ("CAP"). The Company shareholders invested \$127,616 of equity capital and obtained a \$285,840 loan from the Water Infrastructure Finance Authority of Arizona ("WIFA") to provide funds to acquire a CAP water allocation. The Company engaged in activities and incurred costs for well feasibility reports, consultants, engineers, legal fees and archaeological studies, as well as agreeing to a contract with the City of Scottsdale for treatment and transportation of its CAP water allocation to the Company's service area. The process of developing a CAP water source began in 1996 and was completed in 2002.

Staff recommends approval of its rates and charges on Schedule 4.

TABLE OF CONTENTS

	<u>PAGE</u>
FACT SHEET	1
Company Statistics:.....	1
Rates:.....	1
Customers:	2
Notifications:.....	2
Complaints:	2
SUMMARY OF FILING	3
COMPANY BACKGROUND	3
CONSUMER SERVICES	3
ENGINEERING ANALYSIS	4
ARSENIC	4
MARICOPA COUNTY ENVIRONMENTAL SERVICES (MCES) DEPARTMENT COMPLIANCE	5
ARIZONA CORPORATION COMMISSION COMPLIANCE.....	5
ARIZONA DEPARTMENT OF WATER RESOURCES (ADWR) COMPLIANCE.....	5
OFF-SITE FACILITIES HOOK-UP FEE TARIFF	5
RATE BASE	5
OPERATING REVENUES	6
OPERATING EXPENSES	7
REVENUE REQUIREMENT AND RATE DESIGN	9
STAFF RECOMMENDATIONS	9

SCHEDULES AND TABLES

Summary of Filing	Schedule 1
Rate Base	Schedule 2
Statement of Operating Income	Schedule 3
Rate Design.....	Schedule 4
Typical Bill Analysis	Schedule 5
Staff's Depreciation Expense Calculation	Table A

Attachment

Engineering Report

Fact sheet

Company Statistics:

CC&N: Decision No. 55491, dated March 19, 1987

Current Rates: Decision No. 61109, dated August 28, 1998

Type of Ownership: "S" Corporation

Arizona Corporation Commission Class D Water Utility

Location: Tonto Hills Utility Company is located in Maricopa County where it abuts the far northeast corner of Scottsdale on Cave Creek Road where it enters the Tonto National Forest.

Rates:

Permanent Rate Application Filed: March 31, 2004

Current Test Year Ended: December 31, 2002

Prior Test Year Ended: December 31, 1997

	<u>Current Rates</u>	<u>Company Proposed Rates</u>	<u>Staff Recommended Rates</u>
Residential – 5/8" x 3/4" & 3/4" Meters	\$40.00	\$ 70.00	\$40.00
Gallons included in minimum	N/A	N/A	N/A
Excess of minimum – per 1,000 gallons			
All gallons	\$ 6.80	N/A	N/A
From 0 to 8,000 gals.	N/A	\$ 10.60	N/A
From 8,001 to 16,000 gals.	N/A	12.60	N/A
Over 16,000 gals.	N/A	14.10	N/A
From 0 to 4,000 gals.	N/A	N/A	\$ 6.80
From 4,001 to 13,000 gals.	N/A	N/A	\$10.20
Over 13,000 gals.	N/A	N/A	\$12.30
Typical residential bill based on median usage of 5,261 gallons	\$75.77	\$125.77	\$80.06

Customers:

Number of customers in the prior test year (12/31/1997): 103
Number of customers in the current test year (12/31/2002): 109

Notifications:

Customer notification mailed: March 31, 2004

Complaints:

Number of customer complaints since rate application filed: 0
Percentage of complaints to customer base: 0 percent

Number of customer opinions against proposed rate increase: 22
Percentage of opinions to customer base: 20.2 percent

Summary of Filing

The Test Year results as adjusted by Utilities Division Staff ("Staff"), for Tonto Hills Utility Company ("Tonto Hills" or "Company") show total operating revenue of \$111,617 and an operating income of \$24,704 for an 5.32 percent rate of return on an original cost rate base ("OCRB") of \$464,733 as shown on Schedule 1.

The Company's proposed rates, as filed, would produce total operating revenue of \$194,617 and operating income of \$67,575 for an operating margin of 34.72 percent and an 11.20 percent rate of return on an OCRB of \$603,390. The Company's proposed rates would increase the typical residential bill, with a median usage of 5,261 gallons, by \$50.00, or 66.0 percent, from \$75.77 to \$125.77 (See Schedule 5, Page 1).

Staff recommends rates that would produce total operating revenue of \$126,769 and operating income of \$39,856, for an operating margin of 31.44 percent and an 8.58 percent rate of return on an OCRB of \$464,733. Staff's recommended rates would increase the typical residential bill, with a median usage of 5,261 gallons, by \$4.29, or 5.7 percent, from \$75.77 to \$80.06.

Company Background

On March 31, 2004, the Company filed its rate case due to the extensive effort and process required to obtain an allocation of 71 acre-feet of water from the Central Arizona Project ("CAP"). The Company shareholders invested \$127,616 of equity capital and obtained a \$285,840 loan from the Water Infrastructure Finance Authority of Arizona ("WIFA") to provide funds to acquire a CAP water allocation. The Company engaged in activities and incurred costs for well feasibility reports, consultants, engineers, legal fees and archaeological studies, as well as agreeing to a contract with the City of Scottsdale for treatment and transportation of its CAP water allocation to the Company's service area. The process of developing a CAP water source began in 1996 and was completed in 2002.

Tonto Hills is an "S" corporation that was granted a Certificate of Convenience and Necessity by the Commission to provide water utility service to the public in Decision No. 55491, dated March 19, 1987. The Company currently serves approximately 116 customers. Its service area is located in Maricopa County where it abuts the far northeast corner of Scottsdale on Cave Creek Road where it enters the Tonto National Forest. There are approximately 200 residential and 20 commercial lots available for a total of 220 potential customers. All current customers are residential.

Consumer Services

A review of Consumer Service's records indicates that there were three complaints, twelve inquiries, and twenty-two opinions regarding Tonto Hills between the years of 2001 and

2004. All three complaints were related to new service issues. Three of the inquiries occurred during 2004 and involved rate case issues. All twenty-two opinions were received in 2004 and expressed opposition to the rate increase.

The Corporations Division of the Arizona Corporation Commission reported that Tonto Hills is in good standing.

The Company has a Cross-Connection/Backflow Tariff and a Curtailment Tariff Plan on file.

Engineering Analysis

John A. Chelus, Utilities Engineer, inspected the system on June 18, 2004. Donald J. Unthank, President, and Lou Frederick, the On-site manager, represented the Company.

The system has been plagued with an inadequate water supply for years. In addition, the groundwater is high in radiochemicals. The Company owns two wells located on Forest Service property. Only one of these wells was operational during the test year. That well produced 11 gallons per minute ("gpm") until the pump motor burned out on April 26, 2004. Neither of these wells is currently operational. A treatment system was installed in approximately 1996 to remove the radiochemicals.

Currently, the used and useful plant consists of a 64,000-gallon storage tank, a gravity fed distribution system, hydrants, meters and services. The Company's only current water source is the Central Arizona Project ("CAP"). The Company purchased 30 acre-feet of treatment capacity from the City of Scottsdale. The Company has made provision to purchase an additional 41 acre-feet of treatment capacity from the City of Scottsdale to meet increased future demand. Please refer to the attached Engineering Report for a more detailed description of the water system.

Arsenic

The U.S. Environmental Protection Agency ("EPA") has reduced the arsenic maximum contaminant level (MCL) in drinking water from 50 micrograms per liter (" $\mu\text{g/l}$ ") to 10 $\mu\text{g/l}$. The date for compliance with the new MCL is January 23, 2006. The most recent lab analysis by the Company indicated that the arsenic level in its well source supply is 14 $\mu\text{g/l}$. Based on this arsenic level, the Company will be required to implement a plan to address this issue if it should choose to re-establish use of its wells. It is not known if the existing treatment facilities would remove the arsenic to an acceptable level. This is another reason for the Company to shift from groundwater to treated CAP water. Staff recommends that the Company avoid the costs associated with treating the groundwater for arsenic and radiochemicals by using only CAP water.

Maricopa County Environmental Services (MCES) Department Compliance

Maricopa County Environmental Services (MCES) reported that the water system (PWS-07-076) is in total compliance with the state drinking water rules. MCES certified that the water system is delivering water that does not exceed any maximum contaminant level and meets the water quality standards of the Safe Drinking Water Act.

Arizona Corporation Commission Compliance

The Utilities Division Compliance Unit reports that there are no outstanding compliance issues.

Arizona Department of Water Resources (ADWR) Compliance

The Company is not subject to the gallons per capita day ("gpcd") limit and conservation rules because it pumps less than 250 acre-feet per year, and it is therefore considered a small provider by ADWR.

Off-Site Facilities Hook-Up Fee Tariff

Tonto Hills submitted a proposal for a hook-up fee in its application to assist in the purchase of treatment and transport capacity from the City of Scottsdale for its remaining 41 acre-feet CAP allocation. Staff agrees with the cost analysis presented by the Company. Staff supports a hook-up fee for Tonto Hills and recommends adoption of the specific tariff language prepared by Staff and contained in Exhibit 5 of the attached Engineering Report. The recommended hook-up fees are shown on Schedule 4.

Rate Base

Staff recommends a rate base of \$464,733, a decrease of \$138,658 from the Company's proposed rate base of \$603,390, as shown on Schedule 2, page 1. Staff's rate base results from adjustments to plant, accumulated depreciation and cash working capital.

Staff's adjustments to Plant in Service resulted in a net decrease of \$131,630, from \$763,259 to \$631,629 as shown on Schedule 2, page 1, Adjustment A. Detail of Staff's Plant in Services adjustments are as follows:

CAP Allocation was reduced by \$242, from \$413,698 to 413,456. This adjustment reflects the removal of \$1,527 of costs from 2001 that should have been expensed in accordance with the National Association of Regulatory Utility Commissioners ("NARUC") Uniform System of Accounts ("USOA") and the reclassification of \$1,285 of expenses regarding invoices from Henry L. Howe

that should be capitalized. This results in a negative net adjustment of \$242 as shown on Schedule 2, page 2.

Wells and Springs totaling \$50,197 was reduced to \$0 as shown on Schedule 2, page 2. This reflects the removal of plant items that are not used and useful as the pump burned out rendering the well inoperable. A test to determine the water level of the well did not find water at 500 feet. An obstruction prevented a deeper search.

Pumping Equipment totaling \$47,247 was reduced to \$0 as shown on Schedule 2, page 2. This adjustment reflects the removal of plant items that are not used and useful as the pump burned out and is out of operation.

Water Treatment Equipment totaling \$26,269 was reduced to \$0, as shown on Schedule 2, page 2. This adjustment reflects a \$7,675 reclassification from Miscellaneous Equipment for evaporative troughs that were misclassified; a \$1,404 reclassification from Rental Expense for the rental of a back hoe used for the addition of the evaporative troughs that should have been capitalized in accordance with the NARUC USOA; and removal of the resulting \$35,348 Water Treatment Equipment account balance because the water treatment equipment is not used and useful as the well it supports is out of service.

As noted above, Miscellaneous Equipment was reduced by \$7,675, from \$13,555 to \$5,880, as shown on Schedule 2, page 2.

Staff decreased Accumulated Depreciation by \$8,813, from \$171,887 to \$163,074 as shown on Schedule 2, page 1, Adjustment B. Staff calculated accumulated depreciation by beginning with the amount approved by the Commission in the prior rate case and adding Staff's computed depreciation expense for the intervening years. Staff removed accumulated depreciation related to the plant not considered used and useful.

Staff recalculated Cash Working Capital using the formula method that recognizes one-twenty-fourth of purchased power and purchased water expenses plus one-eighth of operating expenses less depreciation, taxes and purchased power and water expenses resulting in a net decrease of \$5,400 as shown on Schedule 2, page 1, Adjustment C.

Staff removed all \$10,440 of prepayments claimed by the Company because this amount is already included in rate base as a component of plant associated with the allocation of CAP water as shown on Schedule 2, page 1, Adjustment D.

Operating Revenues

Staff verified and accepts the Company's test year total operating revenue of \$111,617 as shown on Schedule 3, page 1.

Operating Expenses

As shown on Schedule 3, page 1, Staff adjustments decrease total operating expenses by \$40,129, from \$127,042 to \$86,913.

Staff increased Purchased Water Expense by \$6,220, from \$22,670 to \$28,890, to annualize purchased water expenses using CAP water from the City of Scottsdale to reflect discontinuation of groundwater use and exclusive use of CAP water as shown on Schedule 3, page 2, Adjustment A. Staff calculated its recommended Purchase Water Expense by beginning with the Company's total gallons sold during the test year of 8,470,000 gallons. Staff allowed for water loss of up to ten percent and calculated that the total gallons required was 9,411,000 gallons. This amount was used to calculate the annualized water costs from the City of Scottsdale at \$24,039. This would result in the Company incurring \$1,798 of OM & R charges (9,411,000 gallons = 29 acre-feet x \$62) and \$3,053 of M & I charges (71 acre-feet x \$43) from the Central Arizona Project.

Staff decreased Purchased Power Expense from \$2,582 to \$0 to eliminate purchased power expenses related to the removal of plant determined not to be used and useful as shown on Schedule 3, page 2, Adjustment B.

Staff decreased Chemicals Expense from \$405 to \$0 to eliminate chemical expense for treatment of groundwater to reflect discontinuation of groundwater use and exclusive use of CAP water delivered by the City of Scottsdale that has already been treated as shown on Schedule 3, page 2, Adjustment C.

Staff, decreased Repairs and Maintenance Expense by \$361, from \$2,745 to \$2,384, to remove the purchase of salt from the repairs and maintenance expense account to reflect discontinuation of groundwater use and exclusive use of CAP water delivered by the City of Scottsdale that has already been treated as shown on Schedule 3, page 2, Adjustment D.

Staff decreased Outside Services Expense by \$9,665 from \$21,908 to \$12,243, as shown on Schedule 3, page 2, Adjustment E. This adjustment removes \$1,080 for water testing fees that will not be required due to the discontinued use of groundwater and a \$3,800 double count of costs also recorded in the CAP Allocation plant account and reclassifies \$4,785 of costs that should be capitalized: \$1,285 to the CAP Allocation and \$3,500 to Water Treatment Equipment plant accounts.

Staff decreased Rent Expense from \$1,404 to \$0 to reclassify rental expenses to water treatment plant as shown on Schedule 3, page 3, Adjustment G. These rental cost were incurred for the use of a back hoe to place evaporative troughs into service. The rental expenses of \$1,404 should be reclassified and capitalized as Water Treatment Plant in accordance with the NARUC USOA.

Staff decreased Regulatory Commission Expense by \$30,333, from \$33,333 to \$3,000 as shown on Schedule 3, page 3, Adjustment H. This adjustment recognizes \$9,000 of rate case expense over three years to provide a normalized amount of \$3,000 per year. Tonto Hills did not effectively monitor and control its rate case costs, and the Company could not provide adequate support for its claimed costs. In response to Staff's initial request for support, the Company provided invoices to unrelated operating and maintenance expense accounts. In response to Staff's follow-up request for supporting documentation, Tonto Hills' consultant, DCI, Inc., created invoices, all dated August 2, 2004, derived from DCI's time sheets. Tonto Hills had not received a bill for services provided by DCI since May 2, 2003. Staff's review of DCI's invoices revealed inefficient activities and misclassified costs.

The short-form rate increase application for Class D and E water companies provides a relatively simple process that has assisted many utilities' efforts to effectively complete rate proceedings at minimal cost. The Company's ability to incur a large rate case obligation due to inadequate control should not be a burden for ratepayers. Staff concludes that Tonto Hills imprudently incurred rate case costs, and that the amount requested for recovery is unreasonable for a Class D utility.

Staff increased Depreciation Expense by \$736, from \$15,695 to \$16,431, as shown on Schedule 2, page 3, Adjustment I, to reflect application of Staff's recommended depreciation rates to Staff adjusted plant in service. Staff's rates are consistent with the range of anticipated economic useful life of plant equipment. Staff amortized the Company's CAP Allocation at 2.86 percent to reflect the 35 year remaining lives of the CAP contracts with the Central Arizona Water Conservation District and the City of Scottsdale. For all other rates, please see Exhibit 4 of the attached Engineering Report. Refer to Table A for a detailed calculation of Staff's Depreciation Expense.

Staff decreased test year Income Tax Expense by \$86, from \$86 to \$0, as shown on Schedule 3, page 3, Adjustment J, because as an "S" corporation the Company does not pay income taxes.

Revenue Requirement and Rate Design

Staff recommends total operating revenues of \$126,769, an increase of \$15,152, or 13.57 percent, over test year revenues of \$111,617. Staff's recommended revenue provides an 8.58 percent rate of return on a rate base of \$464,733 and an operating margin of 31.44 percent as shown on Schedule 1.

Staff and the Company agree that the present one-tier rate structure should be replaced with a three-tier inverted block rate structure to help promote efficient water use as shown on Schedule 4. Staff's recommended rate design retains the present minimum charge and the first tier commodity rates, thus placing the revenue requirement increase in the second and third commodity tier rates. The recommended rate structure gives customers the ability to control their bills with good water use management. The Company proposed and Staff recommended rate designs are shown on Schedule 4.

The present reconnection charge is \$25.00 for normal and after-hours reconnects. The Company proposes to increase the after-hours reconnect charge to \$50.00. The Company provided no support for this proposed increase, therefore, Staff recommends retaining the present charge.

Tonto Hills requests an increase in the service line and meter installation charges for 2-inch and smaller meters. Staff recommends approval of these charges as well as amounts for other meter sizes as shown on Schedule 4.

Staff Recommendations

Staff recommends approval of its rates and charges as shown on Schedule 4.

Staff further recommends that all funds collected by the Company as off-site facilities Hook-Up Fees shall be deposited into a separate interest bearing trust account and used solely for the purposes of paying for the costs of off-site facilities and repayment of loans obtained for the installation of off-site facilities.

Staff further recommends that the Commission order the Company to docket annual water Hook-Up Fee account reports. The Hook-Up Fee Report should cover the calendar year period and be due by April 15th of each year disclosing:

1. Name of each entity paying Hook-Up Fee in the previous calendar year;
2. Amount of Hook-Up Fee paid by each entity in the previous calendar year;
3. Description of utility plant constructed with Hook-up Fee funds in the previous calendar year;
4. Balance of Hook-Up Fee account at the end of the previous calendar year;
5. Interest earned on Hook-Up Fee account in the previous calendar year;

6. Any other pertinent information that may be required by Staff.

Staff further recommends that the Company maintain its books and records in accordance with the NARUC Uniform System of Accounts that has been adopted by the Commission.

Staff further recommends that in addition to the collection of its regular rates and charges, the Company shall collect from its customers their proportionate share of any Privilege, Sales or Use Tax as provided for in A.A.C. R14-2-409(D).

SUMMARY OF FILING

	-- Present Rates --		-- Proposed Rates --	
	Company as Filed	Staff as Adjusted	Company as Filed	Staff as Adjusted
Revenues:				
Metered Water Revenue	\$109,879	\$109,879	\$193,748	\$125,900
Unmetered Water Revenue	1,738	1,738	869	869
Other Water Revenues	0	0	0	0
Total Operating Revenue	\$111,617	\$111,617	\$194,617	\$126,769
Operating Expenses:				
Operation and Maintenance	\$106,789	\$66,010	\$106,789	\$66,010
Depreciation	15,695	16,431	15,695	16,431
Property & Other Taxes	4,472	4,472	4,472	4,472
Income Tax	86	0	86	0
Total Operating Expense	\$127,042	\$86,913	\$127,042	\$86,913
Operating Income/(Loss)	(\$15,425)	\$24,704	\$67,575	\$39,856
Rate Base O.C.L.D.	\$603,390	\$464,733	\$603,390	\$464,733
Rate of Return - O.C.L.D.	-2.56%	5.32%	11.20%	8.58%
Times Interest Earned Ratio (Pre-Tax)	-1.40	2.50	-1.40	3.98
Debt Service Coverage Ratio (Pre-Tax)	0.07	1.36	0.07	3.18
Operating Margin	-13.82%	22.13%	34.72%	31.44%

- NOTES: 1. The times interest earned ratio (TIER) represents the ability of the Company to pay interest expenses before taxes.
2. Operating Margin represents the proportion of funds available to pay interest and other below the line or non-ratemaking expenses.

RATE BASE

	----- Original Cost -----			Staff
	Company	Adjustment		
Plant in Service	\$763,259	(\$131,630)	A	\$631,629
Less:				
Accum. Depreciation	171,887	(8,813)	B	163,074
Net Plant	\$591,372	(\$122,817)		\$468,555
Less:				
Plant Advances	\$0	\$0		\$0
Accumulated Deferred Income Taxes	9,666	0		9,666
Total Advances	\$9,666	\$0		\$9,666
Contributions Gross	\$0	\$0		\$0
Less:				
Amortization of CIAC	0	0		0
Net CIAC	\$0	\$0		\$0
Total Deductions	\$9,666	\$0		\$9,666
Plus:				
1/24 Power & Water	\$1,052	\$152	C	\$1,204
1/8 Operation & Maint.	10,192	(5,552)	C	4,640
Inventory	0	0		0
Prepayments	10,440	(10,440)	D	0
Total Additions	\$21,684	(\$15,841)		\$5,844
Rate Base	\$603,390	(\$138,658)		\$464,733

Explanation of Adjustment:

- A See Schedule 2, Page 2
- B See Schedule 2, Page 3
- C Reflects Staff's adjustments to Purchased Water, Purchased Power and Operating Expense.
- D Reflects Staff's disallowal of Prepayments as they are already recorded in Plant

PLANT ADJUSTMENT

	Company Exhibit	Adjustment		Staff Adjusted
301 Organization	\$385	\$0		\$385
302 Franchises	0	0		0
303 Land & Land Rights	35,282	0		35,282
303.1 CAP Allocation	413,698	(242)	A	413,456
304 Structures & Improvements	2,277	0		2,277
307 Wells & Springs	50,197	(50,197)	B	0
311 Pumping Equipment	47,247	(47,247)	C	0
320 Water Treatment Equipment	26,269	(26,269)	D,E	0
330 Distribution Reservoirs & Standpipes	12,483	0		12,483
331 Transmission & Distribution Mains	136,063	0		136,063
333 Services	14,598	0		14,598
334 Meters & Meter Installations	3,650	0		3,650
335 Hydrants	1,325	0		1,325
336 Backflow Prevention Devices	0	0		0
339 Other Plant and Misc. Equipment	0	0		0
340 Office Furniture & Equipment	6,230	0		6,230
341 Transportation Equipment	0	0		0
343 Tools Shop & Garage Equipment	0	0		0
344 Laboratory Equipment	0	0		0
345 Power Operated Equipment	0	0		0
346 Communication Equipment	0	0		0
347 Miscellaneous Equipment	13,555	(7,675)	E	5,880
348 Other Tangible Plant	0	0		0
105 C.W.I.P.	0	0		0
TOTALS	\$763,259	(\$131,630)		\$631,629

Explanation of Adjustment:

- A To remove \$1,527 of capital costs related to M & I Charges that should have been expensed in accordance with the NARUC USOA. To reclassify \$1,285 of outside service expense related to the Henry L. Howe invoices which should be capitalized in accordance with the NARUC USOA. A net adjustment of (\$242).
- B To remove Wells and Springs as plant no longer used and useful. The pump is no longer in operation rendering the well no longer used and useful.
- C To remove Pumping Equipment as plant no longer used and useful. The pump burned out and is no longer in service.
- D To remove Water Treatment Equipment as plant no longer used and useful. To reclassify \$7,675 regarding evaporative troughs from Miscellaneous Equipment to Water Treatment Equipment according to the NARUC USOA. To reclassify \$1,404 related to the rental of a back hoe used for the addition of the evaporative troughs from Rental Expense which should have been capitalized under Water Treatment Equipment according to the NARUC USOA. Finally, to remove the \$35,348 resulting Water Treatment Equipment balance which eliminates not used and useful plant that is out of service.
- E To reclassify \$7,675 related to evaporative troughs from Miscellaneous Equipment to Water Treatment Equipment according to the NARUC USOA.

ACCUMULATED DEPRECIATION ADJUSTMENT

	<u>Amount</u>
Accumulated Depreciation - Per Company	\$171,887
Accumulated Depreciation - Per Staff	163,074 A
Total Adjustment	<u>(\$8,813)</u>

Explanation of Adjustment:

A -	Accum. Depr. As of December 31, 1996, per Decision No. 60893		\$ 170,163
	Plus:		
	Depreciation Expense	1998 \$ 15,273	
		1999 16,911	
		2000 19,137	
		2001 20,433	
		2002 29,509	
			\$ 101,263
	Less:		
	Plant Accum. Depr. Removals	1998 \$ -	
		1999 -	
		2000 -	
		2001 -	
		2002 108,352	
			(108,352)
	Accumulated Depreciation as of December 31, 2002		<u>\$ 163,074</u>

STATEMENT OF OPERATING INCOME

	Company Exhibit	Staff Adjustments	Staff Adjusted
Revenues:			
461 Metered Water Revenue	\$109,879	\$0	\$109,879
460 Unmetered Water Revenue	1,738	0	1,738
474 Other Water Revenues	0	0	0
Total Operating Revenue	\$111,617	\$0	\$111,617
Operating Expenses:			
601 Salaries and Wages	\$8,425	\$0	\$8,425
610 Purchased Water	22,670	6,220 A	28,890
615 Purchased Power	2,582	(2,582) B	0
618 Chemicals	405	(405) C	0
620 Repairs and Maintenance	2,745	(361) D	2,384
621 Office Supplies & Expense	821	0	821
630 Outside Services	21,908	(9,665) E	12,243
635 Water Testing	2,676	(2,249) F	427
641 Rents	1,404	(1,404) G	0
650 Transportation Expenses	28	0	28
657 Insurance - General Liability	9,138	0	9,138
659 Insurance - Health and Life	0	0	0
666 Regulatory Commission Expense - Rate Case	33,333	(30,333) H	3,000
675 Miscellaneous Expense	654	0	654
403 Depreciation Expense	15,695	736 I	16,431
408 Taxes Other Than Income	0	0	0
408.11 Property Taxes	4,472	0	4,472
409 Income Tax	86	(86) J	0
Total Operating Expenses	\$127,042	(\$40,129)	\$86,913
OPERATING INCOME/(LOSS)	(\$15,425)	\$40,129	\$24,704
Other Income/(Expense):			
419 Interest and Dividend Income	\$985	\$0	\$985
421 Non-Utility Income	0	0	0
427 Interest Expense	10,263	0	10,263
4XX Reserve/Replacement Fund Deposit	12,901	0	12,901
426 Miscellaneous Non-Utility Expense	0	0	0
Total Other Income/(Expense)	(\$22,179)	\$0	(\$22,179)
NET INCOME/(LOSS)	(\$37,604)	\$40,129	\$2,525

STAFF ADJUSTMENTS

A -	PURCHASED WATER - Per Company Per Staff	\$22,670 28,890	<u> </u> <u> </u> \$6,220
	To annualize the purchase of water from the City of Scottsdale.		
B -	PURCHASED POWER - Per Company Per Staff	\$2,582 0	<u> </u> <u> </u> (\$2,582)
	To remove the purchased power expense of \$2,582 related to plant removed from plant in service.		
C -	CHEMICALS - Per Company Per Staff	\$405 0	<u> </u> <u> </u> (\$405)
	To remove chemical expense as water is now treated by the City of Scottsdale.		
D -	REPAIRS AND MAINTENANCE - Per Company Per Staff	\$2,745 2,384	<u> </u> <u> </u> (\$361)
	To remove purchase of salt from Repairs and Maintenance, as water is already treated by the City of Scottsdale.		
E -	OUTSIDE SERVICES - Per Company Per Staff	\$21,908 12,243	<u> </u> <u> </u> (\$9,665)
	To reflect the removal of \$1,080 of water testing fees and \$3,800 already accounted for in plant under the CAP Allocation account, and reclassify \$1,285 to the CAP Allocation account and \$3,500 to Water Treatment Plant.		
F -	WATER TESTING - Per Company Per Staff	\$2,676 427	<u> </u> <u> </u> (\$2,249)
	To reflect the Staff calculation of normalized annual water testing costs.		

STAFF ADJUSTMENTS (Cont.)

G -	RENTS - Per Company	\$1,404	
	Per Staff	0	<u>(\$1,404)</u>

To reclassify \$1,404 of backhoe costs that should be capitalized as Water Treatment Plant according to the NARUC USOA.

H -	REGULATORY COMMISSION EXPENSE - RATE CASE	\$33,333	
	- Per Company	3,000	<u>(\$30,333)</u>
	Per Staff		

To normalize Staff's recommended Rate Case Expense level of \$9,000 over three years.

I -	DEPRECIATION - Per Company	\$15,695	
	Per Staff	16,431	<u>\$736</u>

To reflect the application of Staff's recommended rates to Staff's recommended plant by account.

J -	INCOME TAX - Per Company	\$86	
	Per Staff	0	<u>(\$86)</u>

To remove income taxes as an "S" corporation pays none.

RATE DESIGN

Monthly Usage Charge	Present	-Proposed Rates-	
	Rates	Company	Staff
5/8" x 3/4" Meter	\$ 40.00	\$ 70.00	\$ 40.00
3/4" Meter	40.00	70.00	40.00
1" Meter	90.00	158.00	100.00
1 1/2" Meter	115.00	200.00	200.00
2" Meter	155.00	270.00	320.00
3" Meter	N/A	490.00	640.00
4" Meter	N/A	630.00	1,000.00
6" Meter	N/A	840.00	2,000.00
Gallons Included in Minimum	0	0	0
Excess of Minimum - per 1,000 gallons	\$ 6.80	N/A	N/A
From 0 to 8,000 gallons	N/A	\$ 10.60	N/A
From 8,001 to 16,000 gallons	N/A	12.60	N/A
Over 16,000 gallons	N/A	14.10	N/A
From 0 to 4,000 gallons	N/A	N/A	\$ 6.80
From 4,001 to 13,000 gallons	N/A	N/A	10.20
Over 13,000 gallons	N/A	N/A	12.30
<u>Off-Site Facilities Hookup Fees</u>			
5/8" x 3/4" Meter	N/A	\$ 3,000.00	\$ 3,000.00
3/4" Meter	N/A	4,500.00	4,500.00
1" Meter	N/A	7,500.00	7,500.00
1 1/2" Meter	N/A	15,000.00	15,000.00
2" Meter	N/A	24,000.00	24,000.00
3" Meter	N/A	52,500.00	52,500.00
4" Meter	N/A	90,000.00	90,000.00
6" Meter	N/A	186,000.00	186,000.00
<u>Service Line and Meter Installation Charges</u>			
5/8" x 3/4" Meter	\$600.00	\$800.00	\$800.00
3/4" Meter	600.00	800.00	800.00
1" Meter	700.00	900.00	900.00
1 1/2" Meter	850.00	1,100.00	1,100.00
2" Meter	1,150.00	1,500.00	1,500.00
3" Meter	0.00	0.00	2,245.00
4" Meter	0.00	0.00	3,200.00
6" Meter	0.00	0.00	5,875.00
<u>Service Charges</u>			
Establishment	\$ 15.00	\$ 15.00	\$ 15.00
Establishment (After Hours)	25.00	25.00	25.00
Reconnection (Delinquent)	25.00	25.00	25.00
Reconnection (Delinquent & After Hours)	-	50.00	25.00
Late Fee	-	15.00	1.50%
Deposit	*	0.00%	*
Deposit Interest	*	*	*
Re-Establishment (Within 12 Months)	**	**	**
NSF Check	\$ 25.00	\$ 25.00	\$ 25.00
Deferred Payment	1.50%	1.50%	1.50%
Meter Re-read	\$ 15.00	\$ 15.00	\$ 15.00
Meter Test (Svc Chg Plus Cost of Bench Test)	****	****	****
<u>Monthly Service Charge for Fire Sprinkler</u>			
4" or Smaller	***	\$0.00	***
6"	***	0.00	***
8"	***	0.00	***
10"	***	0.00	***
Larger than 10"	***	0.00	***

* Per Commission Rules (R14-2-403.B)

** Months off system times the minimum (R14-2-403.D)

*** 1.00% of Monthly Minimum for a Comparable Sized Meter Connection, but no less than \$5.00 per month. The Service Charge for Fire Sprinklers is only applicable for service lines separate and distinct from the primary water service line.

**** \$35.00 plus the cost of the bench test.

Tonto Hills Utility Company
 DOCKET NO. : W-02483A-04-0242
 Test Year Ended December 31, 2002

TABLE A

Staff's Depreciation Expense Calculation

Account Number	Account Description	Plant Account Balance	Fully Depreciated Plant	Depreciable Plant	Depreciation Rate	Depreciation Expense
301	Organization	\$ 385	\$ -	\$ 385	0.00%	\$ -
303	Land & Land Rights	35,282	-	35,282	0.00%	-
303.1	CAP Water Allocation	413,456	-	413,456	2.86%	11,813
304	Structures & Improvements	2,277	-	2,277	3.33%	76
330.1	Storage Tanks	12,483	12,483	-	2.22%	-
331	Transmission & Distrib. Mains	136,063	-	136,063	2.00%	2,721
333	Services	14,598	-	14,598	3.33%	486
334	Meters & Meter Installations	3,650	-	3,650	8.33%	304
335	Hydrants	1,325	-	1,325	2.00%	27
340	Office Furniture & Equipment	6,230	-	6,230	6.67%	416
347	Miscellaneous Equipment	5,880	-	5,880	10.00%	588
		<u>\$631,629</u>	<u>\$ 12,483</u>	<u>\$ 619,146</u>		<u>\$ 16,431</u>

Depreciation Expense per Staff \$ 16,431
 Depreciation Expense per Company 15,695
Staff's Adjustment \$ 736

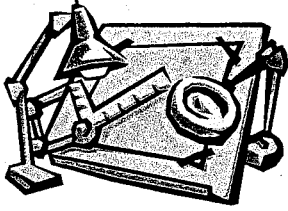

**Engineering Report For
Tonto Hills Utility Company
for a Rate Increase
Docket No. W-02483A-04-0242
By John A. Chelus
July 1, 2004**

EXECUTIVE SUMMARY

Conclusions

- I. Maricopa County Environmental Services ("MCES") reported that the water system is in total compliance with the state drinking water rules. MCES certified that the water system is delivering water that does not exceed any maximum contaminant level and meets the water quality standards of the Safe Drinking Water Act.
- II. Tonto Hills has a curtailment tariff on file with the Utilities Division.

Recommendations

- I. Water testing expenses are based upon participation in the ADEQ Monitoring Assistance Program. Annual testing expenses should be adjusted to the level described in Section G, Table 1 (\$ 510.00).
- II. It is recommended that the Company use depreciation rates by individual National Association of Regulatory Utilities Commissioners ("NARUC") category, as delineated in Exhibit 4.
- III. Staff believes that a hook-up fee is an appropriate method to recover capital costs for future off-site infrastructure. Recommended tariff language is included in Exhibit 5 of this report.

Staff further recommends that all funds collected by the Company as Off-site facilities Hook-up Fees shall be deposited into a separate interest bearing trust account and used solely for the purposes of paying for the costs of off-site facilities and repayment of loans obtained for the installation of off-site facilities.

Staff further recommends that the Commission require the Company to docket annual Water Hook-Up Fee reports. The Hook-Up Fee Report should cover the calendar year period and be due by April 15th of the following year.

1. Name of each entity paying Hook-up Fee;
 2. Amount of Hook-Up Fee paid by each entity;
 3. Description of utility plant constructed with Hook-Up Fee funds;
 4. Balance of Hook-Up Fee account;
 5. Interest earned on Hook-Up Fee account;
 6. Any other pertinent information that may be required by Staff.
- IV. Staff recommends accepting the Company's proposed meter and service line installation charges. In addition, Staff is proposing rates for 4 inch and 6 inch meters as described in Section M.**
- V. Staff recommends removal from rate base of all plant associated with the wells and treatment facilities which are not used and useful at the present time. This plant is described in Section B of this report.**
- VI. Staff recommends using only Central Arizona Project ("CAP") water to avoid the costs associated with treating the groundwater for arsenic and radio-chemicals.**

TABLE OF CONTENTS

	<u>PAGE</u>
ENGINEERING REPORT FOR.....	1
TONTO HILLS UTILITY COMPANY	1
FOR A RATE INCREASE	1
DOCKET NO. W-02483A-04-0242	1
EXECUTIVE SUMMARY	1
A. LOCATION OF COMPANY	4
B. DESCRIPTION OF THE WATER SYSTEM	4
OFF-SITE WATER FACILITIES HOOK-UP FEE TARIFF.....	1
OFF-SITE FACILITIES HOOKUP FEE TABLE	2
METER SIZE.....	2
NARUC METER FACTOR	2
TOTAL FEE.....	2
EXHIBITS	
CERTIFICATED AREA AND LOCATION OF COMPANY	1&2
PROCESS SCHEMATIC	3
DEPRECIATION RATES	4
HOOK-UP FEE TARIFF.....	5

A. LOCATION OF COMPANY

Tonto Hills Utility Company, ("Tonto Hills" or "Company") serves approximately 116 customers and is located in Maricopa County where it abuts the far northeast corner of Scottsdale on Cave Creek Road where it enters the Tonto National Forest. John A. Chelus, Utilities Engineer, inspected the system on June 18, 2004. Donald J. Unthank, President and Lou Frederick, On-site manager, represented the Company. Exhibit 1 describes the location of the Company within Maricopa County, and Exhibit 2 describes the certificated area of the water company within Maricopa County.

B. DESCRIPTION OF THE WATER SYSTEM

Background

The water system serves the Tonto Hills subdivision, which was platted around 1958. There are lots for approximately 220 total customers available. Of these, 200 would be residential. The remaining 20 would be commercial. All 116 current customers are residential. The average lot size is 1.8 acres.

The system has been plagued with an inadequate water supply for years. In addition, the groundwater is high in radiochemicals. The Company owns two wells located on Forest Service property. Only one of the two wells was operable until the pump motor on this well burned out on April 26, 2004. It only produced 11 gallons per minute ("gpm") when it was operational. A treatment system was installed in approximately 1986 to remove the radiochemicals. An application to secure permission to drill more wells on Forest Service Land was disapproved in 1996.

Negotiations began in 1996 with Scottsdale to have Scottsdale treat and deliver Central Arizona Project ("CAP") water to Tonto Hills, if Tonto Hills secured its own allocation of CAP water. In 1997 the Company received approval for a moratorium on new connections until an adequate water supply was found. Negotiations to secure a 71 acre-foot allocation of CAP water from BHP Copper began in 1998. In the meantime, the Company had to haul water to meet demand. On August 11, 1999, Tonto Hills made a request of the City of Scottsdale to install a construction meter and temporary two-inch diameter line from a fire hydrant to the system. This is when water hauling stopped.

In December 1999, the Water Infrastructure Finance Authority of Arizona ("WIFA"), entered into an agreement with Tonto Hills to finance the cost to secure the CAP allocation for 71 acre-feet, to pay increasing pumping capacity of the Scottsdale pump station and purchase treatment capacity in the Scottsdale system for 30 acre-ft/year. The total cost was \$413,456 and the loan amount was \$285,840. The difference came from profits. The approval of the loan occurred in Decision No. 62286 on February 1st, 2000. In January 2000, the Scottsdale City Council approved the treatment and transport agreement. On February 22, 2002, the Superior Court of Arizona ratified the CAP water

supply contract to Tonto Hills. The cost to acquire the allocation of 71 acre-feet was \$101,451. This included fees for consultants and back taxes.

The City of Scottsdale's Pump Station 94 has been upgraded to increase its capacity as part of the agreement with Tonto Hills. In May 2003, the City of Scottsdale converted from reading the fire hydrant meter to reading a permanent 1-1/2 inch diameter meter.

Currently, the used and useful plant consists of a 64,000-gallon storage tank, a gravity fed distribution system, hydrants, meters and services. As of now, 30 acre-ft of treatment capacity has been purchased from the City of Scottsdale. The remaining 41 acre-ft of treatment capacity that will be necessary will be purchased in the near future as demand increases.

Current System Status and Recommended Adjustments to Plant going forward

In April 2004, the well motor for the only remaining 11 gpm well burned up. This was due to a decreasing groundwater table. An attempt was made to measure the static water level. The 500 foot long probe did not encounter any water. This is compared to January 24, 2003, when the static water level was 214 feet. This well is reported to have a depth of 990 feet. Since April 2004 to present, the wells, treatment facilities, and booster pumps have not been used. The well has not been repaired.

Today, Tonto Hills is a consecutive water system to the City of Scottsdale and relies totally on treated CAP water. It is the desire of Tonto Hills to determine what the condition of the well is, and if possible replace the well pump and leave the pump and treatment facilities as stand-by. The Company may choose to do this, however, the plant would not be considered used and useful while in standby mode because it is not needed unless Scottsdale fails to provide water through the interconnection.

Since Tonto Hills is using only CAP water, any operation and maintenance ("O & M") costs, chemical costs, water treatment costs, electric pumping costs, and water testing costs associated with the wells and water treatment system will not be incurred from this time going forward. The Company will no longer be concerned with radiochemicals or arsenic in the water. Only bacteriological and lead and copper testing will be required. Exhibit 3 provides a process schematic for the water system.

Recommended Plant to Be Removed from Rate Base as Not Used and Useful

Account No.	Description	Approx. Year Installed	Original Cost
307	Wells & Springs	1960	\$50,197
311	Pumping Equipment	1986	\$47,247
320	Water Treatment Equipment	1986	\$26,269
320	Water Treatment Equipment	2002	\$43,268
	Total		\$166,981

C. ARSENIC

The U.S. Environmental Protection Agency ("EPA") has reduced the arsenic maximum contaminant level (MCL) in drinking water from 50 micrograms per liter (" $\mu\text{g/l}$ ") to 10 $\mu\text{g/l}$. The date for compliance with the new MCL is January 23rd, 2006. The most recent lab analysis by the Company indicated that the arsenic level in its well source supply is 14 $\mu\text{g/l}$. Based on this arsenic level, the Company will be required to implement a plan to address this issue if it should choose to re-establish use of its wells. It is not known if the existing treatment facilities would remove the arsenic to an acceptable level. This is another reason for the Company to rely completely on the treated CAP water from the City of Scottsdale. Staff recommends using only CAP water to avoid the costs associated with treating the groundwater for arsenic and radiochemicals.

**D. MARICOPA COUNTY ENVIRONMENTAL SERVICES (MCES)
DEPARTMENT COMPLIANCE**

Maricopa County Environmental Services ("MCES") reported that the water system (PWS- 07-076) is in total compliance with the state drinking water rules. MCES certified that the water system is delivering water that does not exceed any maximum contaminant level and meets the water quality standards of the Safe Drinking Water Act.

E. ARIZONA CORPORATION COMMISSION COMPLIANCE

A check with the Utilities Division compliance Unit showed no outstanding compliance issues.

**F. ARIZONA DEPARTMENT OF WATER RESOURCES (ADWR)
COMPLIANCE**

Since the Company pumps less than 250 Acre-ft per year, it is considered a small provider by ADWR and is not subject to the gallons per capita day ("gpcd") limit and conservation rules.

G. WATER TESTING EXPENSES

Tonto Hills is now a consecutive system and the majority of water testing is now done by the City of Scottsdale who provides water to Tonto Hills. Tonto Hills will remain responsible for monthly bacteriological sampling as well as lead and copper monitoring. It is recommended that the Company request a waiver from participation in the ADEQ Monitoring Assistance Program ("MAP") since the wells, if repaired, will be on standby status only. Staff is not including the costs associated with participation in MAP in its estimates.

Table 1 shows the estimated annual monitoring expense, assuming no participation in the MAP program. Water testing expenses should be adjusted to the annual expense amount shown in Table 1, which is **\$510**.

Table 1. Water Testing Cost

Monitoring (Tests per 3 years, unless noted)	Cost per test	No. of tests per 3 years	Total 3 year cost	Annual Cost
Bacteriological - monthly	\$15	72	1080	360
Nitrate - annual	\$25	3	75	25
Lead & Copper - annual	\$25	5	125	42
Total				\$ 427.00

H. WATER USE

Water Sold

Based on the information provided by the Company, water use for April 2003 to April 2004 is shown in the graph. This time period is most representative of the current water usage after the moratorium was lifted. Also, beginning with October 2003, all meters are read on the same day including the City of Scottsdale meter and any well meters when well water is used which provides more accurate data. The highest monthly domestic water use was 289 gal/day per service in July, and the low monthly domestic water use was 190 gal/day-service in January. The average annual use was 228 gal/day per service.

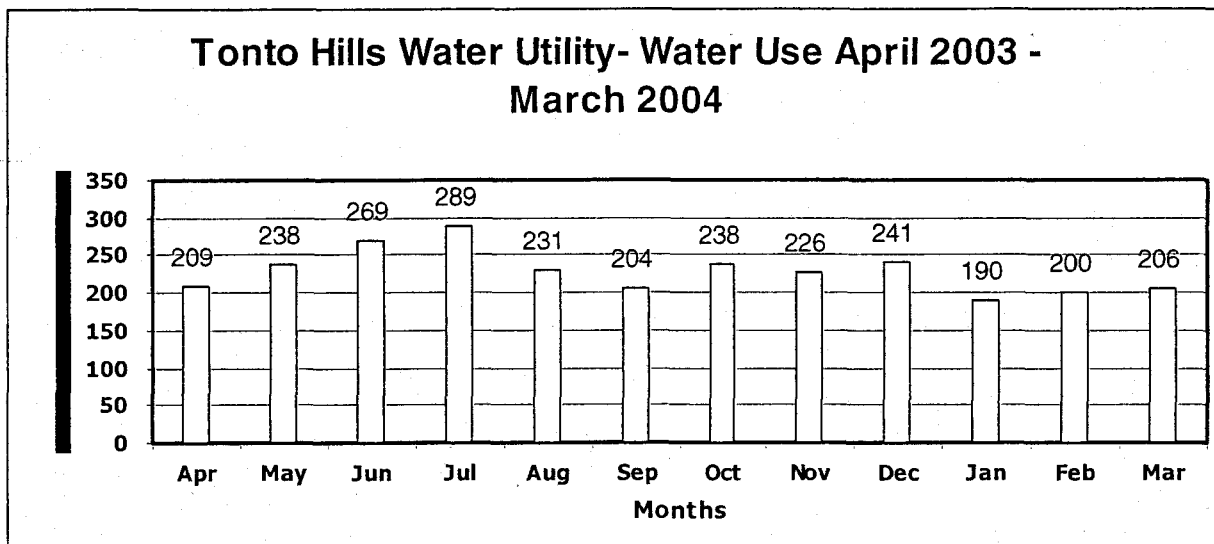

Non-account Water

Non-account water should be 10 percent or less and never more than 15 percent. It is important to be able to reconcile the difference between water sold and the water produced by the source. A water balance will allow a water company to identify water and revenue losses due to leakage, theft, and flushing. During the period from October 2003 through March 2004, when all meter readings were coordinated, the Company reported a loss of 8.43 percent, which is within acceptable limits.

I. GROWTH

Since the moratorium on additional service connections was lifted on July 31, 2003, the number of customers has increased from 100 to 116 as of April 2004.

J. DEPRECIATION RATES

Staff has developed typical and customary depreciation rates within a range of anticipated equipment life. These rates are presented in Exhibit 4. It is recommended that the company use depreciation rates by individual National Association of Regulatory Utilities Commissioners ("NARUC") category, as delineated in Exhibit 4.

K. CURTAILMENT PLAN TARIFF

A curtailment tariff is an effective tool to allow a water company to manage its resources during periods of shortages due to pump breakdowns, droughts, or other unforeseeable events. Tonto Hills has a curtailment tariff on file with the Utilities Division.

L. OFF-SITE FACILITIES HOOK-UP FEE TARIFF

A hook-up fee is an appropriate way to recover the capital burden imposed by new customers. Tonto Hills submitted a proposal for a hookup fee in their application to assist in the purchase of treatment and transport capacity from the City of Scottsdale for their remaining 41 acre-feet CAP allocation. Staff agrees with the cost analysis presented by the Company. Staff supports the concept of a hook-up fee and recommends the adoption of the specific tariff language prepared by Staff and contained in Exhibit 5 of this report.

M. SERVICE LINE AND METER INSTALLATION CHARGES

The Company has requested to change its meter and service line charges as shown in the following table. These charges are refundable advances and the Company's proposed charges are within Staff's experience of reasonable and customary charges. Therefore, Staff recommends accepting the Company's proposed meter and service line installation charges. In addition, Staff is proposing rates for 4 inch and 6 inch meters.

Service Line and Meter Installation Charges

Meter Size	Current Charges	Proposed Charges	Staff Recommendation
5/8 x3/4-inch	\$600	\$800	\$800
3/4-inch	\$600	\$800	\$800
1-inch	\$700	\$900	\$900
1-1/2-inch	\$850	\$1,100	\$1,100
2-inch	\$1,150	\$1,500	\$1,500
3-inch	\$1,720	\$2,245	\$2,245
4-inch			\$3,200
6-inch			\$5,875

EXHIBITS

CERTIFICATED AREA AND LOCATION OF COMPANY EXHIBIT 1 (& 2)

PROCESS SCHEMATIC..... EXHIBIT 3

DEPRECIATION RATES..... EXHIBIT 4

HOOK-UP FEE TARIFF..... EXHIBIT 5

Exhibit 1

MARICOPA COUNTY

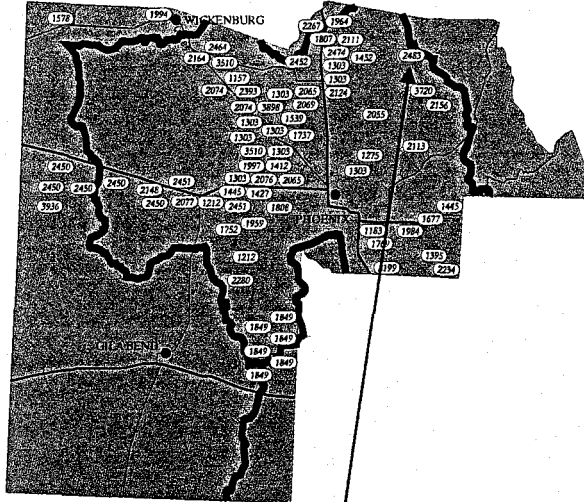

- | | |
|---|---|
| (1997) ADAMAN MUTUAL WATER COMPANY | (1737) NEW RIVER UTILITY COMPANY |
| (1578) AGRILLA WATER SERVICES, INC. | (2099) PIMA UTILITY COMPANY |
| (2077) ALLENVILLE WATER COMPANY, INC. | (2464) PUESTA DEL SOL WATER COMPANY |
| (1303) ARIZONA-AMERICAN WATER COMPANY | (1395) QUEEN CREEK WATER COMPANY |
| (1445) ARIZONA WATER COMPANY | (3898) RANCHO CABRILLO WATER COMPANY |
| (2074) BEARDSLEY WATER COMPANY, INC. | (1808) RIGBY WATER COMPANY |
| (1275) BERNEIL WATER COMPANY | (2156) RIO VERDE UTILITIES, INC. |
| (1964) BLACK CANYON RETREAT WATER COMPANY | (1539) ROSE VALLEY WATER COMPANY |
| (1994) CABALLEROS WATER COMPANY, INC. | (2111) SABROSA WATER COMPANY |
| (1452) CAVE CREEK WATER COMPANY | (1183) SENDE VISTA WATER COMPANY, INC. |
| (2113) CHAPARRAL CITY WATER COMPANY | (2474) SHANGRI-LA ASSOCIATES, INC. |
| (2393) CHAPARRAL WATER COMPANY | (2280) SOUTH RAINBOW VALLEY WATER COOPERATIVE |
| (3510) CIRCLE CITY WATER COMPANY L.L.C. | (2069) SUNRISE WATER COMPANY, INC. |
| (1752) CLEARWATER UTILITIES COMPANY, INC. | (2076) TIERRA BUENA WATER COMPANY |
| (1984) DAIRYLAND WATER CORPORATION | (2483) TONTO HILLS UTILITY COMPANY |
| (2124) DESERT HILLS WATER COMPANY, INC. | (1677) TURNER RANCHES WATER & SANITATION COMPANY |
| (3936) EAGLE TAIL WATER COMPANY LC | (1212) VALENCIA WATER COMPANY |
| (1959) GRANDVIEW WATER COMPANY, INC. | (1412) VALLEY UTILITIES WATER COMPANY, INC. |
| (2234) H2O, INC. | (2148) VALLEY VIEW WATER COMPANY, INC. |
| (2055) JAMES P. PAUL WATER COMPANY | (2451) WATER UTILITY OF GREATER BUCKEYE, INC. |
| (1769) KYRENE WATER COMPANY | (2450) WATER UTILITY OF GREATER TONOPAH, INC. |
| (2452) LAKE PLEASANT WATER COMPANY | (3720) WATER UTILITY OF NORTHERN SCOTTSDALE, INC. |
| (1427) LITCHFIELD PARK SERVICE COMPANY | (1157) WEST END WATER COMPANY |
| (2267) MCADAMS WATER COMPANY | (2065) WILHOIT WATER COMPANY, INC. |
| (1849) MOBILE WATER COMPANY | (1807) WRANGLERS ROOST WATER COMPANY |
| (2164) MORRISTOWN WATER COMPANY | |

Exhibit 2

COUNTY: Maricopa

RANGE 5 East

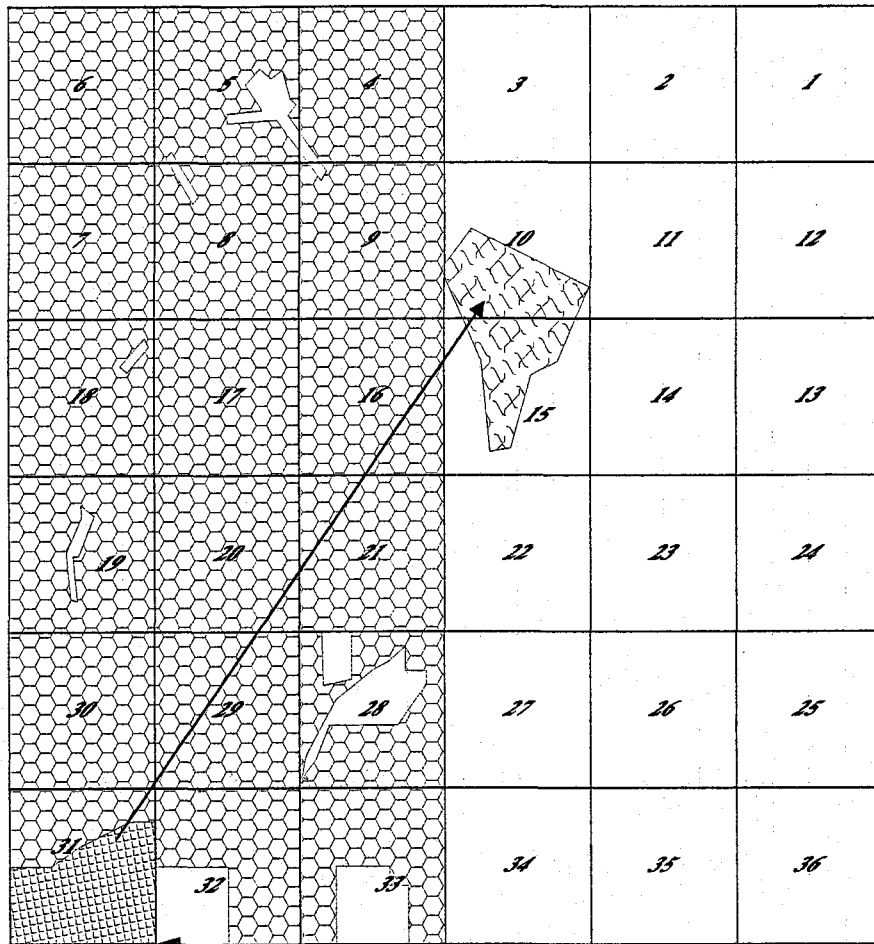

TOWNSHIP 6 North

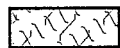

W-2483 (1)

Tonto Hills Utility Company

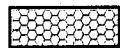

C-0011 (5)

City of Scottsdale (Nonjurisdictional)



C-0023 (3)

Town of Carefree (Nonjurisdictional)

City of Scottsdale
(South 40 Feet of Section 31)

Exhibit 3

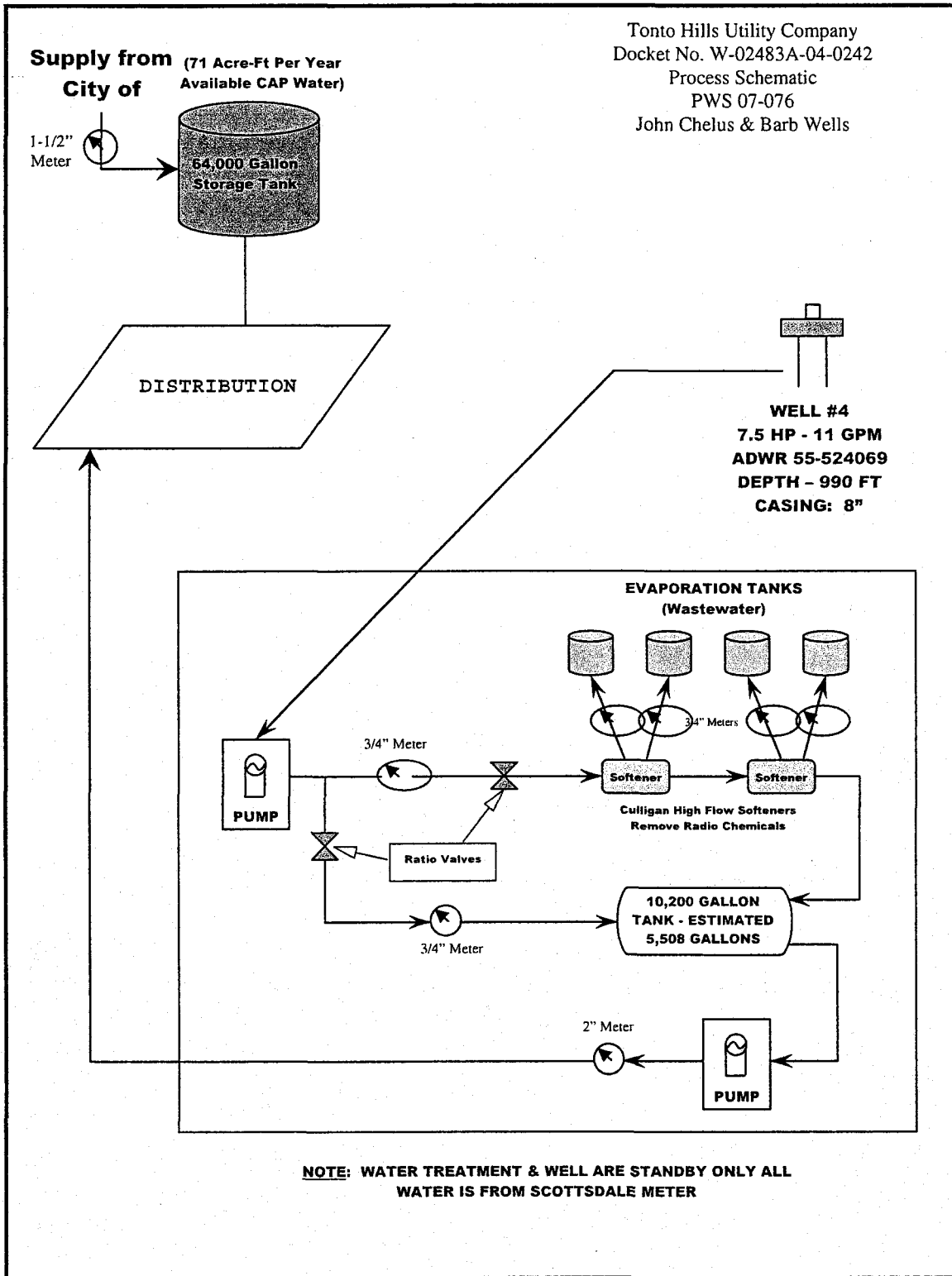

EXHIBIT 4
TYPICAL DEPRECIATION RATES FOR WATER COMPANIES

NARUC Account No.	Depreciable Plant	Average Service Life (Years)	Annual Accrual Rate (%)
304	Structures & Improvements	30	3.33
305	Collecting & Impounding Reservoirs	40	2.50
306	Lake, River, Canal Intakes	40	2.50
307	Wells & Springs	30	3.33
308	Infiltration Galleries	15	6.67
309	Raw Water Supply Mains	50	2.00
310	Power Generation Equipment	20	5.00
311	Pumping Equipment	8	12.5
320	Water Treatment Equipment		
320.1	Water Treatment Plants	30	3.33
320.2	Solution Chemical Feeders	5	20.0
330	Distribution Reservoirs & Standpipes		
330.1	Storage Tanks	45	2.22
330.2	Pressure Tanks	20	5.00
331	Transmission & Distribution Mains	50	2.00
333	Services	30	3.33
334	Meters	12	8.33
335	Hydrants	50	2.00
336	Backflow Prevention Devices	15	6.67
339	Other Plant & Misc Equipment	15	6.67
340	Office Furniture & Equipment	15	6.67
340.1	Computers & Software	5	20.00
341	Transportation Equipment	5	20.00
342	Stores Equipment	25	4.00
343	Tools, Shop & Garage Equipment	20	5.00
344	Laboratory Equipment	10	10.00
345	Power Operated Equipment	20	5.00
346	Communication Equipment	10	10.00
347	Miscellaneous Equipment	10	10.00
348	Other Tangible Plant	----	----

NOTES:

1. These depreciation rates represent average expected rates. Water companies may experience different rates due to variations in construction, environment, or the physical and chemical characteristics of the water.
2. Acct. 348, Other Tangible Plant may vary from 5% to 50%. The depreciation rate would be set in accordance with the specific capital items in this account.

UTILITY: Tonto Hills Utility Company SHEET NO. 1
DOCKET NO. W-02483A-04-0242
DECISION NO. _____
EFFECTIVE DATE: _____

**OFF-SITE WATER FACILITIES HOOK-UP FEE TARIFF
FOR
TONTO HILLS UTILITY COMPANY**

I. Purpose and Applicability

The purpose of the hook-up fees payable to Tonto Hills Utility Company ("the Company") pursuant to this tariff is to equitably apportion the costs of purchasing water treatment and transport capacity from the City of Scottsdale that will be required to serve new customers.

These charges are applicable to all new service connections established after the effective date of this tariff. The charges are one-time charges and are payable as a condition to the Company's establishment of service, as more particularly provided below.

II. Definitions

Unless the context otherwise requires, the definitions set forth in R-14-2-401 of the Arizona Corporation Commission's rules and regulations governing water utilities shall apply in interpreting this tariff schedule.

"Applicant" means any party entering into an agreement with Company for the installation of water facilities to serve new service connections.

"Company" means Tonto Hills Utility Company, an Arizona corporation.

"Main Extension Agreement" means any agreement whereby an Applicant agrees to advance the costs of the installation of water facilities to the Company to serve new service connections, or install water facilities to serve new service connections and transfer ownership of such water facilities to the Company, which agreement shall require the approval of the Arizona Corporation Commission (same as line extension agreement).

"Off-Site Facilities" means treatment and transport capacity purchased from the City of Scottsdale to treat and transport the Central Arizona Project ("CAP") allocation owned by the Company, which facilities will benefit the entire water system.

"Service Connection" means and includes all service connections for single-family residential, commercial, industrial, or other uses, regardless of meter size.

III. Off-Site Hook-Up Charges

Each new service connection shall pay the total off-site facilities hookup fee, derived from the following table:

UTILITY: Tonto Hills Utility Company SHEET NO. 2

DOCKET NO. W-02483A-04-0242

DECISION NO. _____

EFFECTIVE DATE: _____

OFF-SITE FACILITIES HOOKUP FEE TABLE		
Meter Size	NARUC Meter Factor	Total Fee
5/8" x 3/4 "	1	\$3,000
3/4"	1.5	\$4,500
1"	2.5	\$7,500
1- 1/2 "	5	\$15,000
2"	8	\$24,000
3"	17.5	\$52,500
4"	30	\$90,000
6"	62	\$186,000

IV. Terms and Conditions

- (A) Assessment of One Time Hook-Up Charge: The hook-up fee may be assessed only once per service connection, or lot within a platted subdivision (similar to meter and service line installation charges). However, this provision does not exempt from the hook-up fee, any newly created parcel(s) which are the result of further subdivision of a lot or land parcel and which do not have a service connection.
- (B) Use of Off-Site Hook-Up Fee: Hook-Up fees may only be used to pay for the capital items of off-site facilities, or for repayment of loans obtained for installation of off-site facilities. Off site hook-up fees shall not be used for repairs, maintenance, plant replacements, or operational purposes.
- (C) Time of Payment:
- (1) In the event that the Applicant is required to enter into a main extension agreement, whereby the Applicant agrees to advance the costs of installing mains, valves, fittings, hydrants and other on-site improvements in order to extend service in accordance with R-14-2-406 (B), payment of the charges required hereunder shall be made by the Applicant within 15 calendar days after receipt of notification from the Company that the Utilities Division of the Arizona Corporation Commission has approved the main extension agreement in accordance with R14-2-406(M).
 - (2) In the event that the Applicant is not required to enter into a main extension agreement, the charges hereunder shall be due and payable at the time the meter and service line installation fee is due and payable.
- (D) Failure to Pay Charges; Delinquent Payments: – Under no circumstances will the Company set a meter or otherwise allow service to be established if the Applicant has not paid in full all charges as provided by this off-site hook-up fee tariff.

UTILITY: Tonto Hills Utility Company SHEET NO. 3

DOCKET NO. W-02483A-04-0242

DECISION NO. _____

EFFECTIVE DATE: _____

- (E) Off-Site Hook-Up Fee Non-refundable: - The amounts collected by the Company pursuant to the off-site hook-up fee shall be non-refundable contributions in aid of construction.
- (F) Use of Charges Received: All funds collected by the Company as off-site hook-up fees, shall be deposited into a separate interest bearing trust account and used solely for the purposes of paying for the costs of off-site facilities, including repayment of loans obtained for the installation of off-site facilities that will benefit the entire water system.
- (G) All funds collected by the Company as Off-site facilities Hook-up Fees shall be deposited into a separate interest bearing trust account and used solely for the purposes of paying for the costs of off-site facilities, including repayment of loans obtained for the installation of off-site facilities.
- (H) Off-Site Hook-Up Fees In Addition to Other Charges: The off-site hook-up fees shall be in addition to any costs associated with a main extension agreement for on-site facilities, and are in addition to the amounts to be advanced pursuant to charges authorized under other sections of this tariff
- (I) Disposition of Excess Funds: After all necessary and desirable off-site facilities are constructed utilizing funds collected pursuant to the off-site hook-up fee or the off-site hook-up fee has been terminated by order of the Arizona Corporation Commission (Commission), any funds remaining in the trust shall be refunded. The manner of the refund shall be determined by the Commission at the time a refund becomes necessary.

Effective Date: _____

Approved for Filing in Compliance with
Decision No. _____

WESTERN ENVIRONMENTAL TECHNOLOGIES, INC.

P. O. Box 4752 • Cave Creek, Arizona 85327
(480) 488-1385

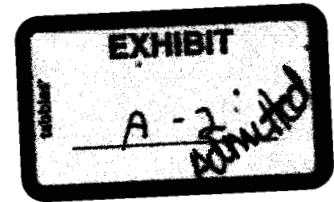

October 17, 2002

Dorothy Hains
Arizona Corporation Commission
1200 West Washington Street
Phoenix, AZ 85007

RE: Arsenic Levels for Tonto Hills Water Company PWS # 07-076

Dear Ms. Hains;

Enclosed is a copy of the laboratory results taken April 25 2001 at the Tonto Hills Water System PWS # 07-076 for Arsenic. The Arsenic level was 0.0082 mg/l which is below the .010 mg/l trigger level per your letter.

Sincerely

A handwritten signature in cursive script, appearing to read "Robert Hanus".

Robert Hanus
(480)488-1385

cc. Mr. Don Unthank, Tonto Hills Water

CLASSIFICATION
OF ARSENIC LEVEL

AZ CORP COMMISSION
DOCUMENT CONTROL

2004 SEP 29 P 12:41

RECEIVED

DRINKING WATER INORGANIC CHEMICAL ANALYSIS REPORT

SAMPLES TO BE TAKEN AT P.O.E ONLY

>>>> PUBLIC WATER SYSTEM INFORMATION <<<<

>>>> TO BE FILLED OUT BY SYSTEM PERSONNEL <<<<

MAP2001

7076

Tonto Hills Utility Co.

System ID

System Name

04/25/01 09:35 (24 hr clock)

Donald J. Unthank

Sample Date Sample time

Owner/Contact Person Name

()

(480) 488 0253

Owner/Contact Fax Number

Owner/Contact Person Phone Number

SAMPLE TYPE

Compliance Monitoring

FOR MCL EXCEEDANCE OR COMPOSITE TRIGGER

[_____]

Original Violating Specimen Number

SAMPLE COLLECTION POINT/ID

Point of Entry# [002 _____]

SAMPLE TYPE

CONFIRMATION

CONFIRMATION FOR COMPOSITE TRIGGER

POE002 PWSID07076

SAMPLING SITE ID

*** INORGANIC CHEMICAL ANALYSIS ***

To be filled out by laboratory personnel

Analy Method	MCL Value	Trigger Value	Contaminant Name	Cont. Code	Test Start Date/Time	Analysis Run Date/Time	Results*	Exceeds MCL	Exceeds Trigger*
200.9	0.050	✓	Arsenic ✓	1005		05/09/01	0.0082 ✓	<input type="checkbox"/>	<input type="checkbox"/>
200.8	2		Barium	1010		05/08/01 12:15	0.0028	<input type="checkbox"/>	<input type="checkbox"/>
200.8	0.005		Cadmium	1015		05/08/01 12:15	< 0.0005	<input type="checkbox"/>	<input type="checkbox"/>
200.8	0.1		Chromium	1020		05/08/01 12:15	0.0018	<input type="checkbox"/>	<input type="checkbox"/>
00F.C	4.0		Fluoride	1025		05/08/01	2.9	<input type="checkbox"/>	<input type="checkbox"/>
245.1	0.002		Mercury	1035		01/30/01 19:23	< 0.0002	<input type="checkbox"/>	<input type="checkbox"/>
	10	5	Nitrate (as N)	1040				<input type="checkbox"/>	<input type="checkbox"/>
	1	0.5	Nitrite (as N)	1041				<input type="checkbox"/>	<input type="checkbox"/>
200.8	0.05		Selenium	1045		05/08/01 12:15	< 0.005	<input type="checkbox"/>	<input type="checkbox"/>
200.8	0.006		Antimony	1074		05/08/01 12:15	< 0.001	<input type="checkbox"/>	<input type="checkbox"/>
200.8	0.004		Beryllium	1075		05/08/01 12:15	< 0.001	<input type="checkbox"/>	<input type="checkbox"/>
4500CN	0.2		Cyanide (as free)	1024		05/04/01	< 0.03	<input type="checkbox"/>	<input type="checkbox"/>
	0.1		Nickel	1036				<input type="checkbox"/>	<input type="checkbox"/>
200.8	0.002		Thallium	1085		05/08/01 12:15	< 0.001	<input type="checkbox"/>	<input type="checkbox"/>
	No MCL		Sulfate	1055				<input type="checkbox"/>	<input type="checkbox"/>
	No MCL		Sodium	1052				<input type="checkbox"/>	<input type="checkbox"/>

>>>> LABORATORY INFORMATION <<<<

To be filled out by laboratory personnel

SPECIMEN NUMBER

[2104270243I]

ID Number [AZ0/4/5/5] Name: [Montgomery Watson Laboratories]

Comments: [78677-2104270243]

Authorized Signature: [*[Signature]*]

Date Public Water System Notified: [_____]

* All units must be reported in milligrams per liter (mg/l)

DWAR2: REVISED 05/08/98

Page 1 of 1

WILLIAM A. MUIDELL
CHAIRMAN
JIM IRVIN
COMMISSIONER
MARC SPITZER
COMMISSIONER



RE SUBMIT

BRIAN C. McNEIL
EXECUTIVE SECRETARY

ARIZONA CORPORATION COMMISSION

DATE: July 16, 2002
TO: COMMISSION REGULATED AFFECTED WATER COMPANIES
RE: ARSENIC LEVEL EXCEEDING 10 PARTS PER BILLION

On December 17, 2001, Staff of the Arizona Corporation Commission wrote a letter to all Commission regulated water companies asking for their arsenic test results. Staff has received your test results and your arsenic level(s) exceeds the new standard of 10 parts per billion ("ppb").

For those water companies whose source(s) exceeds the 10 ppb level, Staff is requesting a detailed plan of how your company plans to achieve compliance by January 2006. Your compliance plan is important to Staff because it will indicate what options of treatment or non-treatment are available and to insure that compliance planning is taking place before the January 2006 compliance deadline.

Please submit the requested detailed plan no later than October 1, 2002. If you have any questions, please feel free to contact me at 602-542-0745 or any of the following Staff:

1. Water Engineers:
John Chelus at 602-542-7273
Dorothy Hains at 602-542-7274
Lyndon Hammon at 602-542-7276
Marlin Scott, Jr. at 602-542-7272
2. Del Smith, Engineering Supervisor at 602-542-7277
3. Steve Olea, Assistant Director at 602-542-7270

7/23/02
SPOKE TO DOROTHY HAINES / ADVISED HER THAT OUR ARSENIC TESTS ARE 5 PPB. SHE WILL RESPOND

Again, thank you for your prompt attention in this manner. As always, Staff stands ready to assist in any way that it can.

Sincerely,

Ernest G. Johnson
Director
Utilities Division

EGJ MSJ:nms

Cover Sheet
Arizona Corporation Commission
Docket Control Center



Company/Case Name TONTO HILLS UTILITY COMPANY
Doing Business As (d/b/a) _____
Docket Number (s) W-02483A-04- 0242

Description of Document or Nature of Action
Please choose the item that best describes the nature of the case/filing.

UTILITIES - NEW APPLICATION

- | | |
|--|---|
| <input type="checkbox"/> New CC&N | <input type="checkbox"/> Main Extension |
| <input checked="" type="checkbox"/> Rates | <input type="checkbox"/> Contract/Agreements |
| <input type="checkbox"/> Interim Rates | <input type="checkbox"/> Formal Complaint |
| <input type="checkbox"/> Cancellation of CC&N | <input type="checkbox"/> Waiver/Rule Variance |
| <input type="checkbox"/> Deletion of CC&N | <input type="checkbox"/> Line Siting Committee Case |
| <input type="checkbox"/> Extension of CC&N | <input type="checkbox"/> Small Water Company - Surcharge |
| <input type="checkbox"/> Tariff (NEW) | <input type="checkbox"/> Sale of Assets & Transfer of Ownership |
| <input type="checkbox"/> Request for Arbitration | <input type="checkbox"/> Sale of Assets & Cancellation of CC&N |
| <input type="checkbox"/> Full or Partially Arbitrated | <input type="checkbox"/> Fuel Adjuster/PGA |
| <input type="checkbox"/> Interconnection Agreement | <input type="checkbox"/> Merger |
| <input type="checkbox"/> Voluntary Interconnection Agreement | <input type="checkbox"/> Financing |
| <input checked="" type="checkbox"/> Miscellaneous - Specify: <u>HOOK-UP RATE</u> | |

UTILITIES - REVISIONS/AMENDMENTS TO PENDING OR APPROVED MATTERS

Application: _____ Tariff: (Promotional or Compliance)
(Circle One)
Company _____ Decision No: _____
Docket Number _____ Docket No: _____

SECURITIES or MISCELLANEOUS FILINGS

- | | |
|---|---|
| <input type="checkbox"/> Affidavit (Publication, Public Notice) | <input type="checkbox"/> Request/Motion for Extension of Time |
| <input type="checkbox"/> Comments | <input type="checkbox"/> Request/Motion for a Hearing |
| <input type="checkbox"/> Exception | <input type="checkbox"/> Request/Motion for an Intervention |
| <input type="checkbox"/> Exhibit(s) | <input type="checkbox"/> Miscellaneous Request/Motion |
| <input type="checkbox"/> Notice of Appearance/Intent | <input type="checkbox"/> Request/Motion for a Re-hearing |
| <input type="checkbox"/> Notice of Errata | <input type="checkbox"/> Request/Motion to Continue Hearing |
| <input type="checkbox"/> Opposition | <input type="checkbox"/> Request/Motion to Strike |
| <input type="checkbox"/> Petition | <input type="checkbox"/> Response |
| | <input type="checkbox"/> Testimony |
| | <input type="checkbox"/> Waiver |
| | <input type="checkbox"/> Witness List |
| | <input type="checkbox"/> Intervention |

OTHER: _____

03-31-04
Date

Leonard L. Dueker...President of DCI, INC..Contact Person
Print the name of the person whose signature appears on the filing
(i.e. Contact Person, Respondent, Attorney, Applicant, etc.)

ARIZONA CORPORATION COMMISSION



**RATE APPLICATION
FOR WATER COMPANIES
WITH ANNUAL GROSS OPERATING REVENUES
(INCLUDING REQUESTED RATE RELIEF)
OF LESS THAN \$250,000
PER ARIZONA ADMINISTRATIVE CODE R14-2-103
Details at website: www.cc.state.az.us**

TONTO HILLS UTILITY COMPANY
UTILITY NAME

DECEMBER 31, 2002
TEST YEAR ENDED

Required invoices to be submitted are listed in the checklist on page 1.

You must complete ALL items in the application according to the instructions provided. If you have any questions regarding the application, call the Chief of Accounting and Rates at (602) 542-0743 for Staff assistance or see our website at: www.cc.state.az.us

IN ORDER TO PROCESS YOUR APPLICATION
FORWARD THE ORIGINAL AND FIFTEEN COPIES OF THE
APPLICATION AND COVER SHEET PLUS THREE
PACKETS WITH COPIES OF
CHECKLIST ITEMS 5-11 (PAGE 1)
TO DOCKET CONTROL CENTER
1200 WEST WASHINGTON STREET
PHOENIX, ARIZONA 85007

Note: Please refer to the checklist on page 1 for the required attachments.

2004 SEP 29 P 12:43

RECEIVED

TABLE OF CONTENTS

WATER RATE APPLICATION CHECKLIST	1
GENERAL INSTRUCTIONS	2
NARRATIVE DESCRIPTION OF APPLICATION FOR RATE ADJUSTMENT.....	3
AFFILIATE RELATIONSHIP	5
STATEMENTS IN SUPPORT OF RATE REQUEST	6
CURRENT AND PROPOSED RATES AND CHARGES INSTRUCTIONS.....	8
CURRENT AND PROPOSED RATES AND CHARGES	9
SERVICE CHARGES INSTRUCTIONS.....	10
CURRENT AND PROPOSED SERVICE CHARGES.....	11
UTILITY PLANT IN SERVICE INSTRUCTIONS.....	12
PLANT ADDITIONS AND RETIREMENTS BY YEAR.....	13
PLANT SUMMARY.....	14
UTILITY PLANT IN SERVICE.....	15
WATER COMPANY PLANT DESCRIPTION.....	16
WATER COMPANY PLANT DESCRIPTION CONTINUED.....	17
WATER USE DATA SHEET	18
COMPARATIVE STATEMENT OF INCOME AND EXPENSE.....	19
CALCULATION OF DEPRECIATION EXPENSE.....	20
BALANCE SHEET	21
BALANCE SHEET (CONTINUED).....	22
ADVANCES IN AID OF CONSTRUCTION (ACCT. 252)	24
GROSS CONTRIBUTIONS IN AID OF CONSTRUCTION (ACCT. 271).....	25
BILL COUNT INSTRUCTIONS.....	26
BILL COUNT WORKSHEET 1 ST QUARTER.....	27
BILL COUNT WORKSHEET 2 ND QUARTER.....	28
BILL COUNT WORKSHEET 3 RD QUARTER.....	29
BILL COUNT WORKSHEET 4 TH QUARTER.....	30
BILL COUNT SUMMARY.....	31
CUSTOMER NOTIFICATION.....	32
APPENDIX: WATER COMPLIANCE AFFIDAVITS AND ADOR TAX CLEARANCE FORM	33

WATER RATE APPLICATION CHECKLIST

Please use the following checklist to ensure that all necessary attachments are included in the application. Provide an explanation for any omitted item. Please include 15 copies of this application in your application submission. Also, please include three packets with copies of checklist items 5-11.

ORIGINAL APPLICATION PACKAGE ITEMS

- 1. The Arizona Department of Environmental Quality ("ADEQ") or Maricopa County Environmental Services Department ("MCESD") compliance status report. Use the appropriate request form in the appendix at the end of this application to obtain the status report. A separate form should be used for each public water system, as defined by ADEQ, that is part of this application. Submit the completed status report(s) obtained from ADEQ or MCESD with your application.
- 2. The Arizona Department of Revenue ("ADOR") certificate of compliance letter of good standing. Use the tax clearance application in the appendix at the end of this application in order to obtain the certificate of compliance. (Send in the certificate of compliance with your application.)
- 3. The utility's most recent ADEQ annual sampling invoice for its Monitoring Assistance Program.
- 4. Invoices for each plant asset purchase in excess of \$100,000 during the Test Year, as well as all of the intervening years since the utility's prior year. **on page Error! Bookmark not defined..**

Please provide 3 packets with copies of the following information to support entries on the Income Statement on page **Error! Bookmark not defined.**

- 5. A breakdown by name of all invoices for the Salaries and Wages expense. (Acct. 601)
- 6. Invoices for Purchased Water during the Test Year. (Acct. 610)
- 7. Invoices for Purchased Power during the Test Year. (Acct. 615)
- 8. Invoices for Repairs and Maintenance in excess of \$150 incurred during the Test Year. (Acct. 620)
- 9. Invoices for Outside Services in excess of \$150 incurred during the Test Year. (Acct. 630)
- 10. Invoices for Water Testing during the Test Year (Acct. 635)
- Statements from the county for Property Tax expenses incurred during the Test Year. (Acct. 408.11)

**SEE APPENDIX B
FOR THESE ITEMS**

Company Name: Tonto Hills utility Company	Test Year Ended: December 31,
--	----------------------------------

APPENDICES

APPENDIX B **Original Application Package Items (Page 1)**

APPENDIX C **Non-Accounted for Water**

APPENDIX D **City of Scottsdale Development fee**

1A

GENERAL INSTRUCTIONS

Processing the request for a rate adjustment requires completion of ALL PARTS of this application. Complete the Narrative Description of the Application for Rate Adjustment on pages 3 and 4, as well as the statements on pages 5 and 6. Read the accompanying instructions and fill in the entries on pages 9 through 31. Dollar amounts should be rounded to the nearest dollar. NO ENTRY SHOULD BE LEFT BLANK. If an amount is zero, enter a zero. **Any application that is found to be insufficient will not be processed until the deficiencies are corrected per A.A.C. R14-2-103.B.7.**

A completed application also requires notification of customers of the rate request. The format of the customer notification letter is provided on page 32 of this application. Use the language and form of this letter in notifying customers. The customer notification must be provided to customers on the same date as the rate application is filed. A copy of this notice, together with a notarized cover letter stating the method of customer notification and the date the notification was sent to the customers, must accompany the application form.

Please provide any supplementary information the Company believes will assist in the evaluation of the rate request. For example, if expense items are substantially different from the latest annual report filed with the Commission, or if significant plant additions have been made since the prior rate increase, attach supporting explanations for those changes to the application. Clearly label any attachments and staple them to the application.

Selection of a Test Year for the utility is an important part of the application. A Test Year older than the year reflected in the most current Annual Report filed with the Utilities Division is usually considered outdated. Questions regarding the selection of a Test Year should be addressed to the Chief of Accounting and Rates at (602) 542-0743.

Please contact the Arizona Department of Environmental Quality (and/or its authorized county agencies) and request a compliance status report. Submit a copy of this report as part of this filing. Please refer to the appendix of this application form.

Please contact the Arizona Department of Revenue and request a certificate of compliance letter of good standing regarding taxes. Submit a copy of this compliance certificate. Please refer to the appendix of this application form.

After you have included all the required items from the checklist on the previous page, please submit the original and fifteen copies of the completed application with a cover sheet to:

Docket Control Center
Arizona Corporation Commission
1200 West Washington Street
Phoenix, Arizona 85007

Also, please include three packets with copies of checklist items 5-11 (see page 1) in your application filing with the Docket Control Center.

NARRATIVE DESCRIPTION OF APPLICATION FOR RATE ADJUSTMENT

Instructions:

Please provide the reasons for your requested rate adjustment by checking the appropriate box(es) below. If desired, the Company may also attach a written narrative regarding its reasons for the requested rate adjustment. Your narrative may also include efforts made by the utility to control costs/expenses and/or mitigate the amount of rate adjustment.

Changes in current, compared to past operations, that necessitate the rate adjustment

Please explain:

The obtainment of a CAP Water Supply. See TONTO HILLS UTILITY COMPANY HISTORY, _____
immediately following this page, that describes the need for a CAP Water Supply and the effort and process
required to obtain the CAP Water Supply. _____

Descriptions and/or calculations of adjustments made to amounts that are included in this application that are different than amounts recorded in your books/ledgers (pro forma adjustments)

Please explain:

See pages 19.1 through 19.4 _____

Significant factors influencing your revenues, expenses and/or rate base

Please explain:

See the TONTO HILLS UTILITY COMPANY HISTORY referenced above. _____

Anticipated growth/decline in customers expected in the next two years, the amount of anticipated construction to serve those customers, and how financed; the type of customers served by the utility, e.g. residential, irrigation, small retail businesses, large commercial, etc.

Please explain:

Growth is anticipated to be spread over the next twenty years, approximately 100 customers total _____
or approximately 5 customers per year. The additional Treat and Transport capacity will be _____
purchased from the City of Scottsdale as growth occurs. This will be financed from the _____
proposed Hook-Up Charges collected. _____ Installation of additional services and meters will be

funded from connection charges. _____

Anticipated construction

Please explain:

No construction will be required to serve these new customers, other than the installation _____
of services and meters. _____

Efforts made to encourage conservation of water through the proposed rate design or through other means

Please explain:

_____ The proposed 3 tiered rates will provide an increased incentive to conserve water. The present rate of _____ water use of the existing customers is substantially less, 1/4 acre foot per year per customer, than _____ the average of approximately 1/2 acre foot per single family residence in the valley. All customers _____ of the TONTO HILLS UTILITY COMPANY are single family residential. _____

Other factors

Please explain:

Attach additional pages as necessary.

HISTORY

TONTO HILLS UTILITY COMPANY HISTORY

FORMATION

The Tonto Hills Utility Company (THUC) is a private utility, subject to regulation by the Arizona Corporation Commission. It serves an existing 40-year-old subdivision in Maricopa County lying immediately adjacent to the City of Scottsdale (COS). It contains 205 lots, with 109 lots connected and served.

The utility was formed by the sub-divider of the land. Because of problems with water quality, and for other reasons he became disenchanted with owning the company, and refused to maintain and/or improve the system. Some of the homeowners in the development purchased the company in order to provide an adequate water supply to the development. Since acquisition they have made improvements to the system, including equipment to treat the water from one of the wells for radiochemicals.

WATER SUPPLY

There were two wells, both of which are located on United States Forest Land, but only one well is now operable and has a capacity of 11 gpm. The well has a high level of radioactivity that must be removed by treatment before delivery to the system.

Recent droughts, together with additional new home construction, resulted in summer demands greater than the well capacity and therefore requiring the trucking of water from an adjacent system.

RISK

With only one very small well providing water for 109 dwelling units, the homes were at very great risk of having only hauled water as their supplemental supply, or if the well is no longer in service their only supply.

OTHER WELLS

Tonto Hills Utility Company (THUC) retained the engineering firm of Brown and Caldwell to prepare a Well Feasibility Report for provision of additional water supply from new wells.

Following this THUC made a request to the Tonto National Forest to drill additional wells on the National Forest.

In a letter dated July 3, 1996 the Forest Service disapproved the application.

CITY OF SCOTTSDALE AGREEMENT

In 1996 DCI, INC. began negotiating with the City of Scottsdale for an agreement to treat and transport water from the CAP Canal through its system to the Tonto Hills Utility System. The initial contacts made it clear that Tonto Hills Utility Company had to provide its own water supply.

MORATORIUM

At this point THUC applied to the Corporation Commission for and received a moratorium (July 2, 1997—DECISION NO. 60266) on new connections to the system until it has demonstrated that it has adequate production to meet demand.

SEARCH FOR CAP WATER

THUC continued to look for CAP Water that could be transferred to THUC. One was the SUNRISE Water Company. In response to an inquiry by DCI, INC., SUNRISE Water Company on August 4, 1997 informed DCI, INC. that they were not interested in transferring their CAP Allocations of either SUNRISE Water Company or WEST END Water Company.

In 1998 THUC's consultants became aware of BHP Copper's desire to transfer its rights to CAP Water to others and worked with the Representatives of BHP Copper, Arizona Department of Water Resources, CAWCD, Bureau of Reclamation, City of Scottsdale, the Town of Carefree and THUC to have the BHP allocation assigned in the following proportions:

Town of Carefree	900 acre-feet
Tonto Hills Utility Company	71 acre feet
City of Scottsdale	<u>1,300 acre-feet</u>
TOTAL	2,271 acre-feet

The 71-acre feet requested by THUC is the total projected ultimate demand of THUC.

TEMPORARY CONNECTION TO THE CITY OF SCOTTSDALE SYSTEM

The one well was not keeping up with the demand of the system, and THUC was hauling water. Because of this, DCI, INC. on August 11, 1999, made a request of the City of Scottsdale to install a construction meter on a fire hydrant near the tank of THUC until the permanent connection to the City's system had been installed and was operational.

The City gave its permission, and a 2-inch PVC line was laid from the tank to the ROW Line of 111th Place. The construction meter was then connected to the 2 inch PVC line by means of garden hoses.

DCI, INC. worked with Desert Properties Limited Partnership for a permanent Easement for the 2-inch pipeline, which was granted to THUC.

Since then the City has been providing Treated CAP Water to the THUC system through the Temporary connection.

WATER INFRASTRUCTURE FINANCING AUTHORITY LOAN

In December of 1999 the Water Infrastructure Finance Authority of Arizona entered into a Loan Agreement with THUC agreeing to provide financing of the Costs to obtain the CAP Water Supply and have it treated and transported to THUC's system. The loan provided for financing up to \$ 285,840 at 6.2%. The actual costs totaled \$412,936.63 with the difference coming from profits.

APPROVAL OF THE WIFA LOAN BY THE CORPORATION COMMISSION

On October 5, 1999 THUC filed with the Arizona Corporation Commission an application for approval to borrow \$285,840 in long-term debt from the Water Infrastructure Finance Authority of Arizona for the purpose of purchasing existing Central Arizona Project ("CAP") allocations, a development fee for treatment of the CAP water, consulting fees, plant additions and delivery charges associated with the CAP water. On the 1st day of February, 2000, Decision NO. 62286, DOCKET NO. W-02483A-99-0558, the application was approved.

CITY OF SCOTTSDALE TREAT AND TRANSPORT AGREEMENT

In January 2000 the Treat and Transport Agreement between THUC and the City of Scottsdale was approved by the City Council.

CAP WATER SUPPLY

On February 22, 2002 the Superior Court of the State of Arizona ratified, confirmed, and validated the Subcontract for Central Arizona Project Water, entered into on July 20, 2002, by and among the United States of America, the Central Arizona Water Conservation District and Tonto Hills Utility Company.

PUMP STATION 94

One of the requirements of the City to deliver the ultimate CAP supply to the THUC system was to increase the capacity of Pump Station 94, owned by the City of Scottsdale. Desert Mountain Development needed to, also, increase its capacity. THUC and Desert Mountain negotiated an agreement to accomplish the rebuild. The construction is complete.

Mountain negotiated an agreement to accomplish the rebuild. The construction is complete.

WAIVER OF COS REQUIREMENT FOR AN ORIFICE PLATE

In the agreement with the COS there was a requirement that an orifice plate be installed in the line from the meter to the tank to restrict the flow from the COS system to a maximum of 70 gpm. While using the temporary connection, the operator of the THUC system became concerned that the installation of an orifice plate would not permit the receipt of the full 70 gpm from the COS System. DCI, INC. worked with the operator and became equally concerned. Calculations were prepared by DCI, INC. and shared with the COS. The City of Scottsdale waived the requirement to install an orifice plate based on these calculations and the provision that if delivery of more than 70 gpm became a problem for COS customers, THUC would install an orifice plate.

NEW PERMANENT NON-GROUNDWATER SUPPLY ...CAPITAL COSTS

DCI, INC., in behalf of THUC, negotiated an agreement with the City of Scottsdale to treat and transport Water from the Central Arizona Project Canal (The canal transports water from the Colorado River) through the City's system to THUC's system.

THUC, the City of Scottsdale and the Town of Carefree received the transfer of CAP allocations of water previously held by BHP Copper. THUC's share was 71 acre-feet and cost THUC approximately \$37,112.

Federal Law required an Environmental clearance for the Spotted Owl and Indian Artifacts.

This consultant cost totaled \$28,528.

The Bureau of Reclamation assisted in the processing of the required approvals. Their charges were \$8,300.

The charges paid to the CAWCD for back taxes and other charges were \$27,511.

The agreement with the COS provided that THUC would pay the same Development Fee as other new customers. The development fee provides for the portion of the capital cost required to treat and transport the CAP water to THUC. The cost paid in 2002 for transportation of 30 acre-feet was \$180,641.41. The charge to transport the remaining 41 acre feet of CAP water will be paid at some point in the future when additional capacity is required and at the rates in effect at that time. At the current rate the cost to transport all 71 acre feet would have been \$427,515 to supply 205 lots.

Over time THUC will purchase the balance of the 71 acre-feet from the City of Scottsdale. Scottsdale staff has estimated that this charge will increase approximately 5% per year.

In addition THUC must increase the capacity of a COS pump station that will deliver THUC's water to its system. THUC's share of the cost to increase the pump station's capacity was \$67,250.

The combined total of the cost of the CAP water supply, the Environmental Consultant charges, the COS development fee, and the pump station was \$412,936.63. The majority of which (\$285,840) was borrowed from the Water Infrastructure Finance Authority of Arizona at an annual interest rate of 6.25%, with the difference coming from profits .

NEW PERMANENT NON-GROUNDWATER SUPPLY ...OPERATING COSTS

THUC pays to the CAP a charge of approximately \$107 per acre-foot of CAP water used.

In addition THUC pays to the COS a monthly charge for the quantity of CAP water treated and transported by the COS for THUC. This charge is billed at the same rate used to bill COS customers less the cost for the CAP Water paid to the CAWCD by THUC, plus a surcharge of 10% for service outside the City, together with a surcharge of 20% for lifting water to a greater elevation than the average elevation of the COS system.

SATISFACTION OF ALL CONDITIONS OF THE THUC & CITY OF SCOTTSDALE AGREEMENT

On July 1, 2003, David M. Mansfield, General Manager, Water Resources Department, City of Scottsdale signed a letter addressed to Don Unthank, President, Tonto Hills Utility Company **that "confirmed that Tonto Hills Utility Company has satisfied all conditions precedent to the City's treatment and transport obligations under the Agreement and the City stands ready to fulfill its obligations under the Agreement for the delivery of up to 30 acre-feet per year."**

TONTO HILLS UTILITY COMPANY REQUESTS THAT THE ARIZONA CORPORATION COMMISSION STAFF THAT THE MORATORIUM BE LIFTED

On July 15, 2003, THUC requested that the Arizona Corporation Commission lift the moratorium.

...

ARIZONA CORPORATION COMMISSION TERMINATED THE MORATORIUM ON NEW CONNECTIONS

On July 31, 2003, the Arizona Corporation Commission, by Staff Memorandum to Docket Control (Docket No. W-02483A-97-0306, Decision No. 60266), "Staff has determined that the Company has met the requirements for cessation of the moratorium on new connections, as contemplated in Decision No. 60266, and therefore, the moratorium approved for Tonto Hills in Decision No. 60266 shall no longer be in effect."

TONTO HILLS UTILITY COMPANY ADVISE ITS CUSTOMERS THAT THE MORATORIUM HAS BEEN TERMINATED

On August 8, 2003, Don Unthank, President, advised the Customers of THUC that:

1. The Tonto Hills Utility Company had satisfied the requirements of the Federal and Local Governments regarding the through put of CAP water to the community.
2. The Arizona Corporation Commission had terminated the moratorium on new meter connections per THUC's request.

BENJAMIN FRANKLIN'S PERSPECTIVE

Benjamin Franklin, in his Poor Richard's Almanac, provided us with the following:

*"When the well's dry,
We know the worth of water."*

AUG-13-2003 16:54

AZ CORP COMM

6025422129

P.01

MEMORANDUM

RECEIVED

TO: Docket Control
Arizona Corporation Commission

2003 AUG -1 A 9:42

FROM: Ernest G. ^{ELP}Johnson
Director
Utilities Division

RECEIVED

AZ CORP COMM
DOCUMENT CONTROL

AUG 04 2003

DATE: July 31, 2003

AZ CORPORATION COMMISSION
DIRECTOR OF UTILITIES

RE: TONTO HILLS UTILITY COMPANY, DOCKET NO. W-02483A-97-0306,
Decision No. 60266.

On June 16, 1997, Tonto Hills Utility Company ("Tonto Hills") filed with the Arizona Corporation Commission ("A.C.C.") an application for curtailment of customer water usage. Tonto Hills is a public service corporation providing water service to a Certificate of Convenience and Necessity ("CC&N") territory which is contiguous to the eastern boundary of the Scottsdale, Arizona city limits.

In Decision No. 60266, dated July 2, 1997, the Commission approved a water usage curtailment for Tonto Hills, ordering that zero meter installation permits be granted during the period of the curtailment order. The Commission further stated the following:

"...that the moratorium on new connections remain in place until such time as the Company demonstrates that it has adequate production to meet demand."

As the Company has been unable to secure an adequate water source to meet demand, the curtailment has remained in effect since being ordered in Decision No. 60266.

On January 31, 2000, the Company entered into an agreement with the City of Scottsdale titled "Agreement for Treatment and Transportation of Water Delivered Through the CAP Canal". The treatment and transportation of Central Arizona Project ("CAP") water under this agreement is meant to address the Company's water production needs. However, the agreement required the Company to satisfy certain conditions prior to receiving water from the City of Scottsdale, including the construction of certain system improvements and the payment of development fees.

On July 1, 2003, the City of Scottsdale informed Mr. Don Unthank, President of Tonto Hills, that all the required conditions in the agreement were met and that the City of Scottsdale stood ready to provide treatment and transportation of CAP water.

On July 15, 2003, A.C.C. Staff received a letter from the Company stating that Tonto Hills was requesting that the moratorium associated with Decision No. 60266 be lifted.

After reviewing the filing of the Company, Staff determined that the 30 acrs-feet of water guaranteed by the City of Scottsdale each year represented an adequate amount of production to meet demand.

Based on the fact that the Company has secured an adequate production source, Staff has determined that the Company has met the requirements for cessation of the moratorium on new connections, as contemplated in Decision No. 60266.

Therefore, the moratorium approved for Tonto Hills in Decision No. 60266 shall no longer be in effect.

Originator: Brian K. Bozzo



Water Resources

9388 E. San Salvador Dr.
Scottsdale, AZ 85258

PHONE 480-312-5685
FAX 480-312-5615

July 1, 2003

Don Unthank, President
Tonto Hills Utility Company
11802 E. Blue Wash Road
Cave Creek, AZ 85331

Re: Agreement for Treatment and Transportation of Water Delivered Through the CAP Canal, No. 1999-135-COS, Between the City of Scottsdale and Tonto Hills Utility Company ("Agreement")

Dear Mr. Unthank:

On January 31, 2000, the City of Scottsdale ("City") and Tonto Hills Utility Company ("Company") entered into the above-referenced agreement for the treatment and transportation of Central Arizona Project water. The Agreement requires the Company to satisfy several conditions before the City has any obligation to treat and transport water to the Company, including the payment of development fees and the construction of certain system improvements. This letter will serve to confirm that Tonto Hills Utility Company has satisfied all conditions precedent to the City's treatment and transport obligations under the Agreement and the City stands ready to fulfill its obligations under the Agreement for the delivery of up to 30 acre-feet per year.

Very truly yours,

A handwritten signature in cursive script that reads "David M. Mansfield".

David M. Mansfield
General Manager, Water Resources Department

c: Paul Norman, Assistant City Attorney
Rick Gregoire, Water Resources Analyst

Leonard Dueker, P.E., President, DCI, Inc., 815 S. Rochester, Mesa, AZ 85206
Michael C. Sheedy, Beer, Toone & Sheedy, P.C., 76 E. Mitchell Drive, Phoenix, AZ
85012-2330

c:\data\word\tontohills\agreementconfirmlet

FILE

**TONTO HILLS UTILITY COMPANY
11802 E. Blue Wash Rd.
Cave Creek, AZ 85331**

July 8, 2003

Arizona Corporation Commission
1200 W. Washington St.
Phoenix, AZ 85007

Dear Commissioners,

The Tonto Hills Utility Company (THUC) has completed all of the requirements with various government entities to receive our allocation of C.A.P. water through Scottsdale's distribution system.

(Please see enclosures)

Therefore; T.H.U.C. now requests that decision #60266, which placed a moratorium on new water connections, be rescinded.

Sincerely,

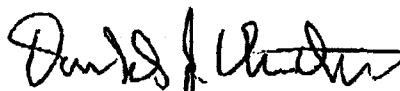

Donald J. Unthank
President, T.H.U.C.

**Tonto Hills Utility
Company**

Memo

To: All Customers
From: Don Unthank
CC:
Date: 08/18/03
Re: Moratorium

Dear Customers:

The Tonto Hills Utility Company has satisfied the requirements of the Federal and Local Governments regarding the through put of CAP water to the community.

The Arizona Corporation Commission has terminated the moratorium on new meter connections per THUC's request.

Thank you for your indulgence in the long process leading to this conclusion.

Thank you,

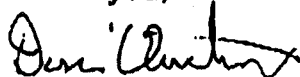

Don Unthank

PAGE

5

AFFILIATE RELATIONSHIP

Please indicate a **yes** or **no** answer to the questions below and provide an explanation where necessary.

A parent-subsidary relationship, or affiliation, with another entity includes corporations, partnerships, sole proprietorship, limited liability corporations (LLCs), as well as common ownership of a water company and another entity, such as a development company or wastewater company.

Are any assets owned jointly with any affiliated or subsidiary entities?

YES NO

If **Yes**, please provide a description of each jointly owned asset, it's cost, and the percentage of the asset owned by the utility. (Please note the amounts reported on pages 13 and 15 should only include the percentage of plant owned by the utility.)

Were any of the assets constructed or acquired from an affiliated or subsidiary entity?

YES NO

If **Yes**, please identify the affiliated entity, the relationship with the utility, and a detailed listing of all transactions reflected in the Plant accounts. Also include detail for other balance sheet accounts, such as Advances, Contributions in Aid of Construction, inter-company payables and receivables, as well as affiliated revenues and expenses from the Company's Income Statement.

STATEMENTS IN SUPPORT OF RATE REQUEST

Complete the following statements in support of your rate request.

 TONTO HILLS UTILITY COMPANY (the "Company") requests an adjustment in the existing rates charged by the Company. The information contained in this application is based upon a twelve-month Test Year ending 12/31/02 (mm/dd/yy). The Company had total operating revenues of \$ 111,617.11 , served 109 metered and 0 un-meter customers, and sold 8,464,509 gallons of water during the Test Year.

(from page 19)

(from page 18)

The Company is requesting a(n) increase/decrease in revenues in the amount of \$ 83,000.00 .

Total annual operating revenues, if the Company is granted the rate adjustment, will be \$ 194,617.11 .

- | | | | |
|---|---|---------------------------------------|----|
| The Company is current on all property taxes. | <input checked="" type="checkbox"/> X YES | <input type="checkbox"/> | |
| The Company is current on all sales taxes.
(Please use the form in the appendix and see checklist item 2 on page 1.) | <input checked="" type="checkbox"/> X YES | <input type="checkbox"/> | NO |
| The Company currently has a Curtailment Plan Tariff on file with the Commission | <input checked="" type="checkbox"/> X YES | <input type="checkbox"/> | NO |
| The Company currently has a Backflow Prevention Tariff on file with the Commission | <input type="checkbox"/> YES | <input checked="" type="checkbox"/> X | NO |

The Company notified its customers of its application for a rate adjustment on _____ (mm/dd/yy). **A COPY OF THE NOTICE WITH A NOTARIZED COVER LETTER STATING THE METHOD OF CUSTOMER NOTIFICATION, AS WELL AS THE DATE OF THE NOTIFICATION, MUST BE ATTACHED. (See page 32)**

By completing this application in support of the Company's request for a rate adjustment, the Company realizes that Original Cost Less Depreciation ("OCLD") plant information will be used to determine the fair value rate base, i.e., the Company waives the right to Reconstruction Cost New.

The utility company ownership is one of the following:

- Sole Proprietorship
- Partnership
- "C" Corporation
- "S" Corporation
- Limited Liability Corporation ("LLC")
- Association--Cooperative
- Other, please specify

Note: If a corporation, please list stockholders and the respective number of shares owned below.

Stockholders	Number of Shares Owned
James Skane	16,000
Bette Shenk Trust	5,000
Dunning Living Trust	3,000
Donald & Mary Ann Unthank	14,000
Donsld Schmid	5,000
Dorothy Frederick	2,000
Larry Sutter	10,500
Robert Sutter	10,500
T.H.U.C. Treasury	5,000
TOTAL	71,000

I have read and completed this application, and to the best of my knowledge all of the information contained herein, and attached to this application, is true and correct.

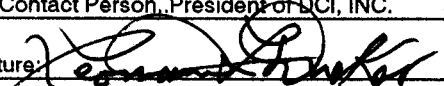
Name of Authorized Representative (print) Leonard L. Dueker for Tonto Hills Utility Company	Company Name: Tonto Hills Utility Company
Title: Contact Person, President of DCI, INC.	Address: 11802 E. BLUE WASH ROAD
Signature: 	Cave Creek, Az 85331
Date: 3-31-04	Phone Number: (480)-488-0253
E-mail Address: lduekerdci@cox.net	Fax Number: (480)-922-9872
Website Address:	Contact Person Phone: (480)-218-5405 Contact Person Fax Num: (480)-699-1978

CURRENT AND PROPOSED RATES AND CHARGES INSTRUCTIONS

Complete the schedules on pages 9 and 11 showing rates and charges currently in effect, and those proposed by the Company. Specify the customer class or classes (i.e., residential, commercial, industrial, irrigation, all, or other classes) in the space provided.

MONTHLY CHARGE:

Enter the monthly minimum (or service) charge and gallons included in the minimum for each meter size. For example, enter "\$12.00 for zero gallons." Propose a monthly minimum (or service) charge for every meter size listed on page 9. Also, enter the commodity (or excess) charge for the gallonage the customer will be charged for gallons used over those included in the minimum charge. For example, enter "\$1.25 per 1,000 gallons." If excess charges vary with gallonage used, enter the rates and gallons covered in each tier of consumption in the space provided. For example:

First Tier	Up to 3,000 gallons	\$1.00 per 1,000 gallons
Second Tier	3,001 to 10,000 gallons	\$1.50 per 1,000 gallons
Third Tier	Over 10,000 gallons	\$2.50 per 1,000 gallons

If a flat rate, rather than a metered rate, is currently approved or proposed, enter the monthly rate in the space provided. A "flat rate" is a charge that is not based on gallons used. (For example, \$10.00 for all the water you can use.) If the Company currently has a flat rate and wishes to continue this rate, please contact the Chief of Accounting and Rates at 602-542-0743. It is likely that Staff will **not** recommend the continuation of such a rate.

CURRENT AND PROPOSED RATES AND CHARGES

CUSTOMER CLASS: Residential Commercial Industrial

Irrigation All Other, specify _____

CURRENT RATES

PROPOSED RATES

MINIMUM OR SERVICE CHARGES
5/8" x 3/4
3/4" Meter
1" Meter
1-1/2" Meter
2" Meter
3" Meter
4" Mete
6" Meter

\$	GALLONS
40.00	for 0.00
40.00	for 0.00
90.00	for 0.00
115.00	for 0.00
155.00	for 0.00

\$	GALLONS
70.00	for 0.00
70.00	for 0.00
158.00	for 0.00
200.00	for 0.00
270.00	for 0.00
490.00	for 0.00
630.00	for 0.00
840.00	for 0.00

GALLONS IN EXCESS OF MINIMUM
Commodity Charge in Excess of Minimum (Charge Per 1,000 Gallons)
First Tier \$10.60
Second Tier \$12.60
Third Tier \$14.10
FLAT RATE

Current Rates

Proposed Rates

Rate	Gallons	Rate	Gallons
\$ 6.80	Up to ALL	\$ 10.60	Up to 8,000
\$	to	\$ 12.60	8,001 to 16,000
\$	Over	\$ 14.10	Over 16,000
\$	Per Month	\$	Per Month

Note: If rates and charges vary across customer classes, duplicate the form and complete one for each rate class. (e.g., residential, commercial) unless "All" is checked.

SERVICE CHARGES INSTRUCTIONS

Listed below are current and proposed service charges as appropriate. Commission Rules should be consulted in proposing new service charges. Please list current and proposed rates on Page 11, as well as any service charges not listed below that the Company proposes to charge.

Service Charge (Commission Rule)	Description
Service Line and Meter Installation Charge (R14-2-405.B)	A refundable Advance in Aid of Construction paid by a new customer to cover the cost of installing all customer piping up to the meter, as well as the cost of installing the meter. Propose a charge for every meter size listed on page 11.
Establishment (R14-2-403.D.1)	A charge covering the cost to establish a new account for a person requesting service when the utility needs only to install a meter for initial establishment, reestablishment, or reconnection.
Establishment (After Hours) (R14-2-403.D.2)	A charge covering the cost to establish a new account for a person requesting service during a period other than regular working hours.
Meter Test (R14-2-408.F)	A charge for testing the accuracy of a meter upon a customer's request. No charge will be levied if the meter is found to be in error by more than +/- three (3) percent.
Deposit (R14-2-403.B)	A refundable security deposit not exceeding two times the average residential class bill for residential customers, and not exceeding two and one-half times a non-residential customer's estimated maximum monthly bill.
Deposit Interest (R14-2-403.B.3)	Annual percentage interest rate applied to customer deposits. A six percent rate shall be applied if the company does not specify an interest rate with the Commission.
Re-establishment (R14-2-403.D.1)	A charge for service at the same location where the same customer had ordered a service disconnection within the preceding twelve-month period.
NSF Check (R14-2-409.F.1)	A fee for each instance where a customer tenders payment for utility service with an insufficient funds check.
Deferred Payment (R14-2-409.G.6)	Applicable monthly finance charges (interest rate) applied in a deferred payment agreement between the company and a customer.
Meter Re-read (R14-2-408.C.2)	Charge for a customer requested re-read of meter applicable when the original reading was found not to be in error.

Company Name: Tonto Hills Utility Company	Test Year Ended: 12/31/2002
--	--------------------------------

CURRENT AND PROPOSED SERVICE CHARGES

CUSTOMER CLASS: Residential Commercial Industrial
 Irrigation All Other, specify _____

SERVICE LINE AND METER INSTALLATION CHARGES	CURRENT CHARGES	PROPOSED CHARGES
5/8" x 3/4" Meter	\$ 600.00	\$ 800.00
3/4" Meter	\$ 600.00	\$ 800.00
1" Meter	\$ 700.00	\$ 900.00
1-1/2" Meter	\$ 850.00	\$ 1,100.00
2" Turbo Meter	\$ 1,150.00	\$ 1,500.00
2" Compound Meter	\$ 1,720.00	\$ 2,245.00
4" Meter		\$ -
6" Meter		\$ -

Establishment	\$ 15.00	\$ 15.00
Establishment (after hours)	\$ 25.00	\$ 25.00
Reconnection (delinquent)	\$ 25.00	\$ 25.00
Reconnection (delinquent) after hours	\$ -	\$ -
Meter Test	\$ 35.00	\$ 35.00
Deposit	*	*
Deposit Interest	**	**
Re-Establishment (within 12 months)	***	***
NSF Check	\$ 25.00	\$ 25.00
Deferred Payment	1.50%	1.50%
Meter Re-read (If Correct)	\$ 15.00	\$ 15.00
Meter Test (Svc Chg Plus Cost of Bnch Test)	\$ 35.00	\$ 35.00

Note: If rates and charges vary across customer classes, duplicate the form and complete one for each rate class. (e.g., residential, commercial) unless "All" is checked.

* Per Commission Rule AAC R-14.2.403.B.7

** Per Commission Rule AAC R14.2.403.B.3

*** Number of months off system times the monthly minimum per Commission Rule AAC R.14.2.403.D

HOOK-UP FEE

Company Name: Tonto Hills Utility Company	Test Year Ended: December 31, 2002
---	--

CURRENT AND PROPOSED RATES AND CHARGES (Continued)

NON-REFUNDABLE OFF-SITE FACILITIES HOOK UP FEE

TONTO HILLS UTILITY COMPANY CURRENTLY OWNS 30 ACRE FEET PER YEAR OF
 TREAT AND TRANSPORT CAPACITY
 FOR WHICH IT PAID THE CITY OF SCOTTSDALE A ONE-TIME FEE OF \$180,641.41

 AS GROWTH OCCURS AND ADDITIONAL TREAT AND TRANSPORT CAPACITY IS REQUIRED,
 TONTO HILLS UTILITY COMPANY MAY PURCHASE ADDITIONAL CAPACITY
 IN 1 ACRE FOOT PER YEAR INCREMENTS AS REQUIRED,
 UP TO A MAXIMUM OF 71 ACRE FEET PER YEAR AT THE THEN APPLICABLE DEVELOPMENT FEE

 THE PROPOSED NON-REFUNDABLE, ONE TIME HOOK-UP FEE WILL BE USED EXCLUSIVELY TO PURCHASE
 THE ADDITIONAL TREAT AND TRANSPORT CAPACITY THAT WILL BE REQUIRED TO SERVE
 THE NEW CUSTOMERS

See Section D for City of Scottsdale Development Fees

**NON-REFUNDABLE, ONE TIME, TONTO HILLS HOOK-UP FEE, TO BE PAID
 WITH THE APPLICATION FOR THE SETTING OF A NEW METER,
 AND PAID IN ADDITION TO THE SERVICE LINE AND METER
 INSTALLATION CHARGES DETAILED ON PAGE 11**

Meter Siz			HOOK-UP FEE
5/8" by 3/4"	Size Factor	1	\$3,000
3/4"	Size Factor	1.50	\$4,500
1"	Size Factor	2.5	\$7,500
1-1/2"	Size Factor	5	\$15,000
2"	Size Factor	8	\$24,000
3"	Size Factor	17.5	\$52,500
4"	Size Factor	30	\$90,000
6"	Size Factor	62	\$186,000

Company Name: Tonto Hills Utility Company	Test Year Ended: December 31, 2002
---	--

**CALCULATION OF HOOK-UP FEE
FOR COS TREAT AND TRANSPORT FACILITIES COSTS**

Year	Initial Treat & Transport Costs			
	AF/Yr of Treat and Transport Capacity Purchased Initially Af/Yr	Payment to COS for 30 AC-Ft/yr of Capacity Service	Total Cost Dollars per AC-FT/YR of Capacity	Rounded Total Cost Dollars per AC-FT/YR of Capacity
2002	30	\$180,640	\$6,021.33	\$6,021

TOTAL TREAT & TRANSPORT CAPACITY

Total Capacity that can be Purchased Over Time AF/YR	Treat and Transport Capacity Purchased Initially AF/YR	Balance of Total Capacity that can be Purchased Over Time AF/YR
71	30	41

**TOTAL TREAT & TRANSPORT COSTS FOR REMAINING 41 ACRE FEET
& HOOK-UP FEE CALCULATION**

CITY OF SCOTTSDALE STAFF ANTICIPATES THAT
THIS FEE WILL INCREASE 5% PER YEAR.

Total Lots in Development	Lots in Service in 2003 With Additions in 2003	Remaining Lots to be Serviced	Balance of Total Capacity that can be Purchased Over Time Af/Yr	Rounded Total Cost Dollars per AC-FT/YR of Capacity See Page 9A For Calculations	Total Cost of Remaining Capacity at 2003/04 Rates	HOOK-UP FEE
						Total Cost of Remaining Capacity at 2003/04 Costs \$/Lot
205	113	92	41	\$6,686	\$274,143	\$2,980

July 1, 2003
through
June 30, 2004

USE
\$3,000.00
FOR 5/8 X 3/4 " METER

Company Name: Tonto Hills utility Company	Test Year Ended: December 31, 2002
--	---------------------------------------

Exhibit "C-1"
WATER NEED REPORT
(For Non-Residential Development Only)
CALCULATION OF CURRENT (EFFECTIVE JULY 1, 2003)
WATER DEVELOPMENT FEE

Owner name: Tonto Hills Utility Company Date: _____

Project Name Agreement for Treatment and Transportation of Water Delivered Through the CAP Canal
Between the City of Scottsdale and Tonto Hills Utility Company

Agreement Number: 1999-135-COS

Fee Calculation Table:

(1)	Total capacity desired for use in a Calendar Year	gallons / year	325,851
(2)	Total capacity purchased prior to this date for use in a calendar year	gallons / year	0
(3)	Additional capacity to be purchased for use in a calendar year (Line (1) minus line (2))	gallons / year	325,851
(4)	Divide line (3) by the number of days in a year		365
(5)	Additional capacity to be purchased (Average Daily Use)	gallons / day	893
(6)	Water Development Fee in effect at this time for Zone B-E in Dollars per gallon / day		\$7.34
(7)	Sub-Total Fees (multiply line (5) by line (6))		\$6,552.73
(8)	2.04% Administration Fee (multiply line (7) by 0.0204)		\$133.68
(9)	TOTAL FEES (line (7) plus line (8))	\$/Annual Af/Yr	\$6,686.41

\$/Annual Af/Yr

I am an officer of the above referenced company and I have prepared the above calculations. I am aware of the penalties and fines that will be enforced against the company, if the average annual water usage in any year exceeds the quantity purchased by ten percent (10%) or more.

TONTO HILLS UTILITY COMPANY

BY: _____ Date: _____
Signature *Title*

BY: _____ Phone Number: _____
Typed Name of party signing

MAIL WITH CHECK TO: Water Resources Department City of Scottsdale 9388 E. San Salvador Drive Scottsdale, Az 85258
--

PAGE

12

UTILITY PLANT IN SERVICE INSTRUCTIONS

Instructions for Page 13

Begin the computation of utility plant in service by completing the worksheet on page 13 labeled Plant Additions and Retirements by Year. On this worksheet insert the dollar amount of plant additions and retirements for each account by year. Provide all additions and retirements for all years beginning with the Test Year in the prior rate case and ending with the test year used in this application. If there are more than two intervening years, make copies of page 13 to report all intervening years.

Instructions for Page 14

Upon completion of the above task, please add all additions on page 13 per plant account and enter the total on page 14 (Plant Summary), column B (Total Additions). Similarly, add all retirements by plant account and enter the total on page 14, column C (Total Retirements).

To assist you in the completion of page 14, please refer to the Commission Decision issued in the Company's prior rate case. That Decision established the value for the Original Cost of the plant and accumulated depreciation at the end of the prior test year. It may be necessary to refer to the associated Staff Report for individual account detail relating to the totals listed in the Decision.

Place the original cost of the plant in service per the prior decision in column A (Plant in Service Per Prior Decision).

Complete column D (Test Year End Total), of page 14, for each plant account by adding column A and B and subtracting column C.

The totals calculated by plant must then be copied to page 15 (Utility Plant in Service), in the column titled Original Cost.

Instructions for Page 15

The Test Year End Totals by plant account on page 14 must be recorded to the Utility Plant in Service worksheet on page 15, in the column titled Original Cost. The second column (Accumulated Depreciation) will include the accumulated depreciation as stated in the Commission's prior Decision plus each year's depreciation expense since the prior Test Year. The third column, Original Cost Less Depreciation is calculated by subtracting Accumulated Depreciation from Original Cost for each account.

Note: For assistance with any of the above, please contact the Chief of Accounting and Rates at 602-542-0743.

Plant Additions and Retirements by Year

Acct. No.	Description	Year 1998		Year 1999		Year 2000		Year 2001		Year 2002		Total	
		Additions	Retirements	Additions	Retirements	Additions	Retirements	Additions	Retirements	Additions	Retirements	Additions	Retirements
301	Organization												
302	Franchises												
303	Land & Land Rights			\$25,260								\$25,260	
303.1	CAP Water Supply Rights	\$6,942		\$66,099		\$11,607		\$23,145		\$281,144		\$412,937	
304	Structures & Improvements												
307	Wells & Springs												
311	Pumping Equipment		(\$2,098)										(\$2,098)
320	Water Treatment Equipment												
320.1	Water Treatment Plants												
320.2	Solution Chemical Feeders												
330	Distribution Reservoirs & Standp/ps												
330.1	Storage Tanks									\$3,205		\$3,205	
330.2	Pressure Tanks												
331	Transmission & Distrib. Mains												
333	Services		\$14,598										
334	Meters & Meter Installations		\$3,650										
335	Hydrants												
336	Backflow Prevention Devices												
339	Other Plant & Misc. Equipment												
340	Office Furniture & Equipment									\$745		\$745	
340.1	Computers & Software												
341	Transportation Equipment												
343	Tools, Shop & Garage Equip.												
344	Laboratory Equipment												
345	Power Operated equipment												
346	Communication Equipment												
347	Miscellaneous Equipment		\$1,654		\$1,654		\$1,654		\$1,654		\$1,654		\$9,270
348	Other Tangible Plant		(\$698)		(\$698)		(\$698)		(\$697)		(\$697)		(\$3,488)
	TOTAL WATER PLANT	\$26,048	\$0	\$114,315	\$0	\$13,308	\$0	\$24,102	\$0	\$285,306	\$0	\$450,417	(\$5,586)

See Appendix B
Section 4.0
for Invoices
of Acct No. 303.1

Invoices N/A

Information N/A
Invoices N/A

Note: Enter all additions and retirements, by year, from the prior test year through the end of the current test year. Enter the totals for the additions and retirements for all intervening years on page 14, Columns B and C, respectively.

Revised 8/27/02

A. SETTLEMENT STATEMENT U.S. DEPARTMENT OF HOUSING AND URBAN DEVELOPMENT



Type of Loan

1. <input type="checkbox"/> FHA 2. <input type="checkbox"/> FmHA 3. <input type="checkbox"/> Conv Unins.	6. File number	7. Loan Number	8. Mortgage Insurance Number
4. <input type="checkbox"/> VA 5. <input type="checkbox"/> Conv. Ins	42-45-00268-BH		

C. NOTE: THIS NOTE IS FURNISHED TO GIVE YOU A STATEMENT OF THE ACTUAL SETTLEMENT COSTS. AMOUNTS PAID TO AND BY THE SETTLEMENT AGENT ARE SHOWN. ITEMS MARKED "(P.O.C.)" WERE PAID OUTSIDE OF THE CLOSING; THEY ARE SHOWN HERE FOR INFORMATIONAL PURPOSES AND ARE NOT INCLUDED IN THE TOTALS.

D. Name and Address of Borrower TONTA HILLS UTILITY COMPANY	E. Name and Address of Seller ROBERT D. SUTTER KATHY D. SUTTER	F. Name and Address of Lender
--	--	-------------------------------

G. PROPERTY LOCATION: VACANT LAND MARICOPA, AZ Lot 228E Tonta Hills	H. Settlement Agent SECURITY TITLE AGENCY Place of Settlement 8787 EAST PINNACLE PEAK, SUITE 120 SCOTTSDALE, AZ 85255	I. Settlement Date 01/19/99
--	---	------------------------------------

J. SUMMARY OF BORROWER'S TRANSACTIONS		K. SUMMARY OF SELLER'S TRANSACTIONS	
100. GROSS AMOUNT DUE FROM BORROWER		400. GROSS AMOUNT DUE TO SELLER	
101. CONTRACT SALES PRICE	25,000.00	401. CONTRACT SALES PRICE	25,000.00
102. PERSONAL PROPERTY		402. PERSONAL PROPERTY	
103. SETTL. CHRGS. TO BORROWER (LINE 1400)	307.00	403.	
104.		404.	
105.		405.	
106. CITY/TOWN TAXES		406. CITY/TOWN TAXES	
107. COUNTY TAXES		407. COUNTY TAXES	
108. ASSESSMENTS		408. ASSESSMENTS	
109. HOA DUES: 01/20/99 TO 03/31/99	9.59	409. HOA DUES: 01/20/99 TO 03/31/99	9.59
110.		410.	
111.		411.	
112.		412.	
20. Gross Amount Due From Borrower	25,316.59	420. Gross Amount Due To Seller	25,009.59
300. AMOUNT PAID BY OR IN BEHALF OF BORROWER		500. REDUCTIONS IN AMOUNT DUE TO SELLER	
201. DEPOSITS		501. EXCESS DEPOSIT (SEE INSTRUCTIONS)	
202. PRINCIPAL AMOUNT OF NEW LOAN(S)		502. SETTL. CHRGS. TO SELLER (LINE 1400)	894.62
203. EXISTING LOAN(S) TAKEN SUBJECT TO		503. EXISTING LOAN(S) TAKEN SUBJECT TO	
204. CLOSING FUNDS	25,259.96	504.	
205.		505.	
206.		506.	
207.		507.	
208.		508.	
209.		509.	
210. CITY/TOWN TAXES		510. CITY/TOWN TAXES	
211. COUNTY TAXES: 01/01/99 TO 01/20/99	59.93	511. COUNTY TAXES: 01/01/99 TO 01/20/99	59.93
212. ASSESSMENTS		512. ASSESSMENTS	
213.		513.	
214.		514.	
215.		515.	
216.		516.	
217.		517.	
218.		518.	
219.		519.	
220. Total Paid By/For Borrower	25,319.89	520. Total Reductions In Amt Due Seller	954.55
600. CASH AT SETTLEMENT FROM/TO BORROWER		600. CASH AT SETTLEMENT FROM/TO SELLER	
301. Gross amounts due from Borrower (line 120)	25,318.59	601. Gross amount due to Seller (line 420)	25,009.59
302. Less amounts paid by/for Borrower (line 220)	25,319.89	602. Less reductions in amount due Seller (line 520)	954.55
303. CASH TO BORROWER	3.30	603. CASH TO SELLER	24,055.04

CLOSING FUNDS TO BE DEPOSITED IN THE FORM OF A BANK WIRE OR CASHIER'S CHECK

REL # 217-12-0208

SECURITY TITLE AGENCY

RECORDING REQUESTED BY:

2208E

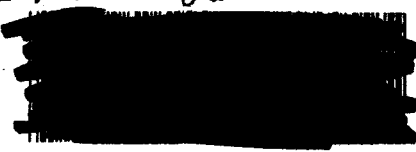

OFFICIAL RECORDS OF MARICOPA COUNTY RECORDER HELEN PURCELL

99-0052669 01/20/99 11:20

VECENTA 187 OF 147

When recorded mail to: Tonto Hills Utility Company

SPACE ABOVE THIS LINE FOR RECORDER'S USE

ESCROW NO. 42-45-00288-BH

SPECIAL WARRANTY DEED

For the consideration of Ten Dollars, and other valuable considerations, I or we, ROBERT D. SUTTER and KATHY D. SUTTER, Husband and Wife and CHARLES LARRY SUTTER, an Unmarried Man as Joint Tenants with Right of Survivorship do hereby convey to TONTO HILLS UTILITY COMPANY, an Arizona Corporation the following described real property situated in Maricopa County, Arizona: LEGAL DESCRIPTION ATTACHED HERETO AS EXHIBIT A AND MADE A PART HEREOF

Subject to: Current taxes, assessments, reservations in patents and all easements, rights of way, encumbrances, liens, covenants, conditions, and restrictions as may appear of record. And the Grantor hereby binds itself and its successors to warrant and defend the title as against all acts of the Grantor herein and no other, subject to the matters above set forth. Dated December 24, 1998

Robert D. Sutter
Kathy D. Sutter
Charles Larry Sutter

Kathy D. Sutter
Kathy D. Sutter

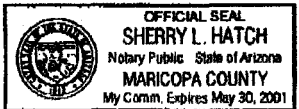

STATE OF ARIZONA
COUNTY OF MARICOPA

This foregoing instrument was acknowledged before me this 14 day of January, 1999 by Robert D. Sutter, Kathy D. Sutter, Charles Larry Sutter

My commission expires May 30, 2001
Sherry L. Hatch
Notary Public

STATE OF
COUNTY OF

This foregoing instrument was acknowledged before me this ___ day of ___, 19__ by

My commission expires
Notary Public

BROWN TANK & STEEL

P.O. Box 20781
Phoenix, Arizona 85036
Phone (602) 243-3053 • Fax (602) 268-6576

INVOICE NO.
3777

DATE
11/19/02

T O B R O W N

TONTO HILLS WATER CO.
11431 E. Manama
Cave Creek, AZ 85331

S H I P T O

TONTO HILLS WATER CO.

QUANTITY SHIPPED	DESCRIPTION	UNIT PRICE	UNIT	AMOUNT
2	8' dia x 32' long open top troughs w/saddles, top angle internal stiffeners. No Paint <i>replacement for old tanks</i>	3550.00	ea	\$7,100.00
				TAX
				575.10
				\$7,675.10

*ck # 2847
11-22-02*

PLEASE PAY THIS AMOUNT →

Thank You

PLEASE PAY THIS INVOICE - NO STATEMENTS ISSUED
A FINANCE CHARGE of 1 1/2% per month (18% PER ANNUM) will be charged on all past due accounts.

Company Name: Tonto Hills Utility Company	Test Year Ended: December 31, 2002
--	---------------------------------------

Plant Summary

Acct. No.	Description	Plant in Service(a) Per Prior Decision	Total Additions	Total Retirements	Test Year End Total
		Column A	Column B	Column C	Column D*
301	Organization	\$385			\$385
302	Franchises	\$0			\$0
303	Land & Land Rights	\$10,022	\$25,260		\$35,282
303.1	CAP Water Supply Rights	\$0	\$412,937		\$412,937
304	Structures & Improvements	\$2,277			\$2,277
307	Wells & Springs	\$50,197			\$50,197
311	Pumping Equipment	\$47,247			\$47,247
320	Water Treatment Equipment	\$26,269			\$26,269
320.1	Water Treatment Plants	\$0			\$0
320.2	Solution Chemical Feeders	\$0			\$0
330	Distribution Reservoirs & Standpipes	\$8,995	\$3,205		\$12,200
330.1	Storage Tanks	\$0			\$0
330.2	Pressure Tanks	\$0			\$0
331	Transmission & Distrib. Mains	\$136,063			\$136,063
333	Services	\$14,598			\$14,598
334	Meters & Meter Installations	\$3,650			\$3,650
335	Hydrants	\$1,325			\$1,325
336	Backflow Prevention Devices	\$0			\$0
339	Other Plant & Misc. Equipment	\$0			\$0
340	Office Furniture & Equipment	\$5,485	\$745		\$6,230
340.1	Computers & Software	\$0			\$0
341	Transportation Equipment	\$0			\$0
343	Tools, Shop & Garage Equip.	\$0			\$0
344	Laboratory Equipment	\$0			\$0
345	Power Operated equipment	\$0			\$0
346	Communication Equipment	\$0			\$0
347	Miscellaneous Equipment	\$5,880	\$8,270		\$14,150
348	Other Tangible Plant	\$3,488		\$3,488.00	\$0
	TOTAL WATER PLANT	\$315,881			\$762,810

(a) Original Cost Plant as Adjusted by Staff in last rate case (Test Year Ended December 31, 1997)

Note: Please refer to the check list on page 1 for the required attachments related to this schedule

*Column D = Column A + Column B - Column C

COMPANY NAME: TONTO HILLS UTILITY COMPANY	Test Year Ended: December 31, 2002
--	---------------------------------------

UTILITY PLANT IN SERVICE

ADDITIONS PRESENTED IN BOLD ITALICS

Acct No	DESCRIPTION	Original Cost (OC) <i>Column A</i>	Accumulated Depreciation <i>Column B</i>	O.C.L.D. (OC less AD) <i>Column C**</i>
301	Organization	\$385	\$0	\$385
302	Franchises	\$0	\$0	\$0
303	Land and Land Rights (a)	\$35,282	N/A	\$35,282
	Water, Treat & Transport Rights	\$0	\$0	\$0
	<i>CAP Water</i>	\$37,112	\$0	\$0
	<i>Environmental Work for CAP Water Transfer</i>	\$28,529	\$0	\$0
	<i>COS Treat & Transport CAP Water ..30 af/yr</i>	\$180,641	\$0	\$0
	<i>COS PS 94 Expansion for THUC Water</i>	\$39,560	\$0	\$0
	WATER, TREAT & TRANSPORT PAID BY WIFA (a)	\$285,842	\$0	\$285,842
	<i>COS PS 94 Balance from earnings</i>	\$27,690	\$0	\$0
	<i>Coldwell/Brown search for wells</i>	\$3,142	\$0	\$0
	<i>Dept of Reclamation not in WIFA</i>	\$5,800	\$0	\$0
	<i>Legal for WIFA Loan</i>	\$2,364	\$0	\$0
	<i>Hustead Engineering..Previous Rate Case</i>	\$16,987	\$0	\$0
	<i>DCI, INC...Previous Rate Case</i>	\$15,000	\$0	\$0
	<i>Hustead Engineering..Additional Services</i>	\$22,012	\$0	\$0
	<i>DCI, INC...Additional Services</i>	\$34,100	\$0	\$0
	SUM OF WATER, TREAT & TRANSPORT PAID FROM EARNINGS (a)	\$127,095	\$0	\$127,095
	TOTAL WATER, TREAT & TRANSPORT PAID FROM WIFA AND EARNINGS	\$412,937	\$0	\$0
304	Structures and Improvements	\$2,277	\$654	\$1,623
307	Wells and Springs	\$50,197	\$35,686	\$14,511
311	Pumping Equipment	\$47,247	\$12,837	\$34,410
320	Water Treatment Equipment	\$26,269	\$11,743	\$14,526
330	Distribution Reservoirs and			
330.1	Standpipes & Collection Reservoirs	\$12,200	\$6,700	\$5,500
331	Transmission and Distribution Mains	\$136,063	\$95,883	\$40,180
333	Services...Staff Change in decision 61109	\$14,598	\$4,643	\$9,955
334	Meters and Meter Installations..Staff Chg 61109	\$3,650	\$1,524	\$2,126
335	Hydrants	\$1,325	\$167	\$1,158
336	Backflow Prevention Devices	\$0	\$0	\$0
339	Pther Plant and Misc. Equipment	\$0	\$0	\$0
340	Office Furniture and Equipment	\$6,231	\$1,517	\$7,748
340.1	Computers & Software	\$0	\$0	\$0
341	Transportation Equipment	\$0	\$0	\$0
343	Tools, Shop and Garage Equipment	\$0	\$0	\$0
344	Laboratory Equipment	\$0	\$0	\$0
345	Power Operated Equipment	\$0	\$0	\$0
348	Communication Equipment	\$0	\$0	\$0
347	Miacellaneous Equipment	\$14,150	\$534	\$13,616
348	Other Tangible Plant	\$0	\$0	\$0
	TOTAL FIXED ASSETS	\$314,207	\$0	\$145,354
	TOTAL WATER PLANT	\$762,810	\$171,887	\$590,923

(a) THUC holds rights to capacity in these facilities, but the assets are owned by others

* Must be the same as the amount reported on page 20

** Column C = Column A - Column B

Company Name: Tonto Hills Utility Company	Test Year Ended: December 31, 2002
---	--

WATER COMPANY PLANT DESCRIPTION

WELLS

ADWR ID Number*	Pump Horse Power	Pump Yield (gpm)	Casing Depth (Feet)	Casing Diameter (inches)	Meter Size (inches)	Year Drilled
55-524--069	7.5	11.1	990	8	TWO 3/4"	?

*Arizona Department of Water Resources Identification Number

OTHER WATER RESOURCES

Name or Description	Capacity (gpm)	Gallons Purchased or Obtained (in Thousands PER YEAR)
CAP Water through City of Scottsdale System	70	9,775.53

BOOSTER PUMPS

Horsepower	Quantity
7.5	1

FIRE HYDRANTS

Quantity Standard	Quantity Other
	7

STORAGE TANKS

Capacity	Quantity
64,000	1
17,000	1

PRESSURE TANKS

Capacity	Quantity

COMPANY NAME: TONTO HILLS UTILITY COMPANY	Test Year: December 31, 2002
--	---------------------------------

WATER COMPANY PLANT DESCRIPTION (CONTINUED)

MAINS		
Size (in inches)	Material	Legth (in feet)
2		
3		
4	Transite	3,382
4	Plastic	4,460
5		
6	Transite	17,733
6	Plastic	3,400
10		
12		

CUSTOMER METERS	
Size (in inches)	Quantity
5/8X3/4	111
3/4	
1	
1 1/2	
2	
Comp. 3	
Turbo 3	
Comp. 4	
Turbo 4	
Comp. 6	
Turbo 6	

For the following three items, list the utility owned assets in each category.

TREATMENT EQUIPMENT:

Two Culligan Hi-flo softener units

STRUCTURES:

Concrete brick building containing the above softeners

OTHER:

WATER USE DATA SHEET

NAME OF COMPANY:	Tonto Hills Utility Company
ADEQ Public Water System Number:	07-076

MONTH/YEAR (12 Months of Test Year)	NUMBER OF CUSTOMERS	GALLONS SOLD (Thousands)	GALLONS PUMPED (Thousands)
1. January, 2002	109	532.009	CAP WATER
2. February, 2002	109	579.890	CAP WATER
3. March, 2002	109	558.660	CAP WATER
4. April, 2002	109	615.091	CAP WATER
5. May, 2002	109	713.239	CAP WATER
6. June, 2002	109	824.810	169.270
7. July, 2002	109	855.560	485.090
8. August, 2002	109	730.260	475.070
9. September, 2002	110	914.938	556.870
10. October, 2002	111	780.132	544.440
11. November, 2002	109	700.682	518.210
12. December, 2002	109	659.238	370.460
TOTAL	N/A	8,464.509	3,119.410

*

**

Is the water utility located within an ADWR Active Management Area ("AMA")?

YES NO

Does the Company have an ADWR gallons per capita per day ("GPCD") requirement?

YES NO

IF YES, please provide the GPCD amount. _____

Note: If you are filing for more than one system, please provide separate data sheet for each system.
For explanation of any of the above, please contact the Engineering Supervisor at 602-542-7277.

* This number must be equal to the number entered on Page 6, "sold gallons."

** Gallons pumped cannot equal or be less than the gallons sold.

WATER USE DATA SHEET

NAME OF COMPANY:	Tonto Hills Utility Company
ADEQ Public Water System Numbe	07-076

Days/ Month	MONTH	Number of Customers	SOLD		
			Total Water Sold (Gallons)	Monthly Average (gal/month/ customer)	Daily Average (gal/day/ customer)
31	Jan	109	532,009	4,881	157.4
28	Feb	109	579,890	5,320	190.0
31	March	109	558,660	5,125	165.3
30	April	109	615,091	5,643	188.1
31	May	109	713,239	6,543	211.1
30	June	109	824,810	7,567	252.2
31	July	109	855,560	7,849	253.2
31	Aug	109	730,260	6,700	216.1
30	Sept	110	914,938	8,318	277.3
31	Oct	111	780,132	7,028	226.7
30	Nov	109	700,682	6,428	214.3
31	Dec	109	659,238	6,048	195.1

365 TOTAL 1,311 8,464,509

ACRE FEET	25.977
-----------	--------

AVERAGE GALLONS PER YEAR PER ACCOUNT	77,656
---	--------

AVERAGE GALLONS PER MONTH PER ACCOUNT	6,471
--	-------

18A

TONTO HILLS UTILITY COMPANY 2002 WATER SALES

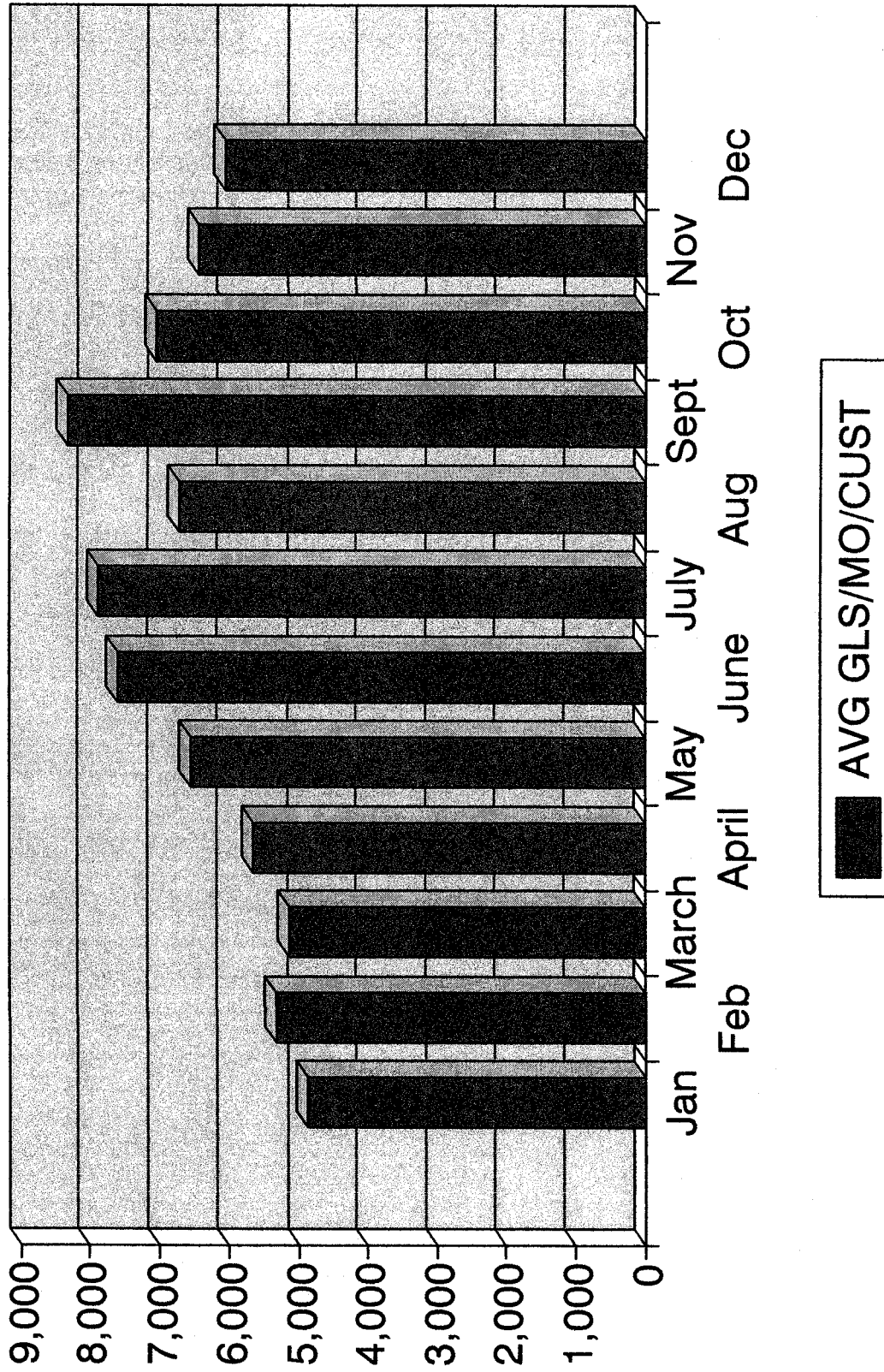

TONTO HILLS UTILITY COMPANY 2002 WATER SALES

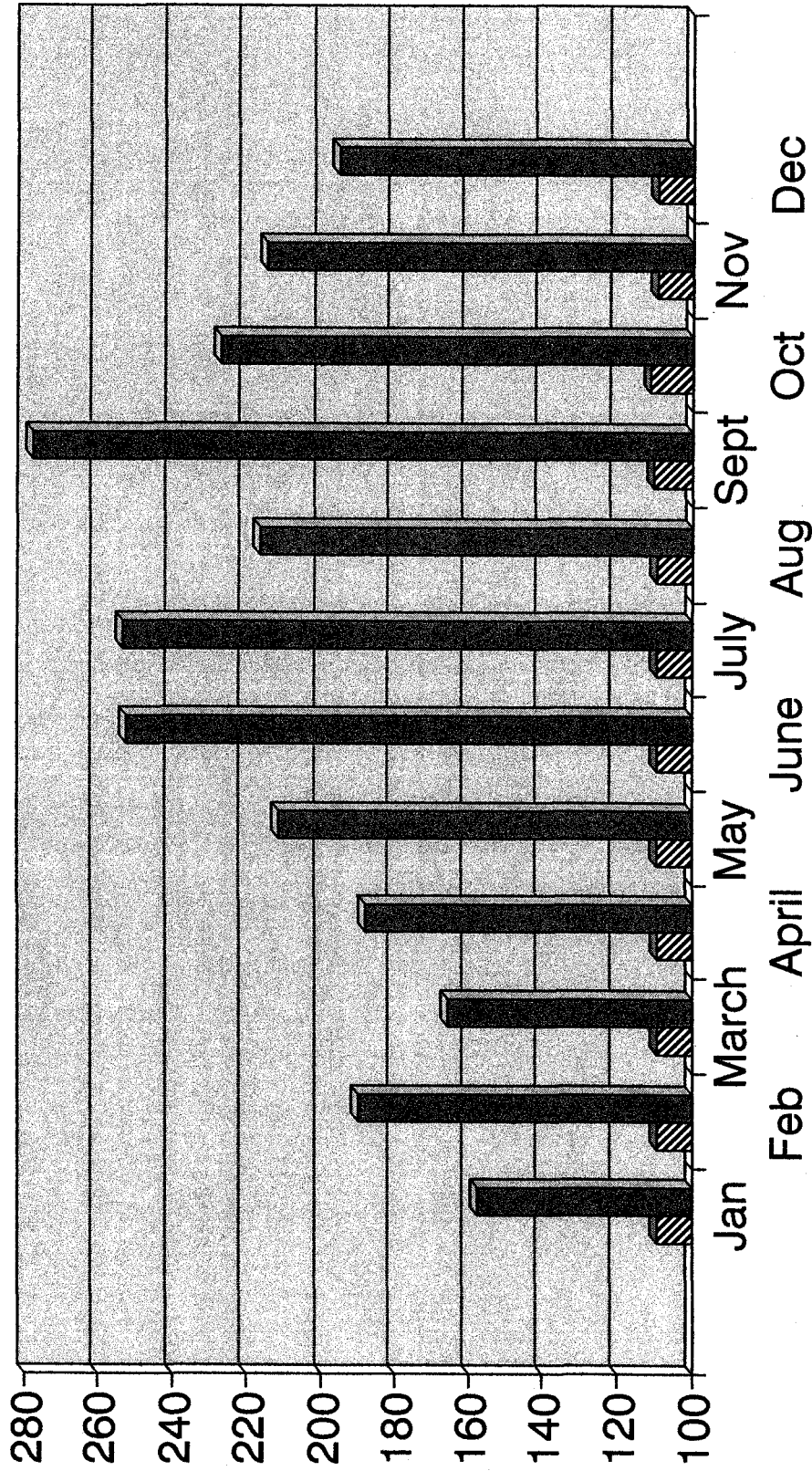

 NO OF CUSTOMERS
  AVG GLS/DAY/CUST

COMPANY NAME: TONTO HILLS UTILITY COMPANY	Test Year Ended: December 31, 2002
--	---------------------------------------

COMPARATIVE STATEMENT OF INCOME AND EXPENSE

Acct. No.	OPERATING REVENUES	PRIOR YEAR	TEST YEAR	
460	Unmetered Water Revenue	\$0	\$0	
460.6	Unmetered Sales - Other	\$0	\$1,738	
461	Metered Water Revenue	\$99,170	\$109,879	
474	Other Water Revenues	\$0	\$0	
474.1	Sales Taxes	\$0	\$0	
474.2	Use Taxes	\$0	\$0	
474.4	Hook-Up Fees	\$0	\$0	
	TOTAL OPERATING REVENUES	\$99,170	\$111,617	
		\$0	\$0	
	OPERATING EXPENSES	\$0	\$0	
601	Salaries and Wages (See page 1, item 5)	\$7,834	\$8,425	
610	Purchased Water (See page 1, item 6)	\$0	\$0	
	CAP M&I and Capital Charge	\$1,527	\$4,589	
	COS Treat & Transport Charges	\$21,189	\$18,081	
615	Purchased Power (See page 1, item 7)	\$0	\$0	
	Well, Treatment Plant & Boosters	\$1,044	\$2,582	
618	Chemicals...Home Depot Salt	\$0	\$405	
620	Repairs and Maintenance (See page 1, item 8)	\$3,551	\$2,745	
621	Office Supplies and Expenses	\$916	\$821	
630	Outside & Professional Services (See page 1, item 9)	\$28,900	\$21,908	
635	Water Testing (See page 1, item 10)	\$5,367	\$2,876	
636	Contractual Services-Other (Service & Meter Installation)	\$0	\$0	
641	Rents (Equipment Rental)	\$1,692	\$1,404	
650	Transportation Expenses	\$47	\$28	
657	Insurance-General Liability	\$2,229	\$9,138	
659	Insurance-Health and Life	\$0	\$0	
666	Regulatory Commission Expense-Rate Case	\$0	\$0	
675	Miscellaneous Expense	\$1,464	\$654	
403	Depreciation Expense (See page 20)	\$15,279	\$15,710	
408	Taxes Other Than Income (ADEQ)	\$410	\$0	
408.1	Federal	\$0	\$58	
408.2	Local	\$0	\$28	
408.3	Property (See page 1, item 11)	\$4,787	\$4,472	
408.4	Sales	\$0	\$0	
408.5	Use	\$0	\$0	
409	Income Tax			
	TOTAL OPERATING EXPENSES	\$96,236	\$93,724	Future Interest
				2003
	OPERATING INCOME/(LOSS)	\$2,934	\$17,893	\$16,191.23
				2004
	OTHER INCOME/(EXPENSE)			\$15,685.54
419	Interest and Dividend Income	\$1,586	\$985	2005
421	Non-Utility Income	\$0	\$0	\$15,103.64
426	Miscellaneous Non-Utility Expenses	\$0	\$0	
427	Interest Expense	(\$728)	(\$10,263)	\$15,680.14
	Acquisition Adj - Income	\$2,636	\$2,636	Avg
	TOTAL OTHER INCOME/(EXPENSE)	\$3,494	(\$6,642)	
	NET INCOME/(LOSS)	\$6,428	\$11,252	

Note: Do not include sales tax in revenue or expense. Please refer to the checklist on page 1 for the required attachments related to this schedule.

*This number must be identical to the number entered on page 6 "total operating revenues."

RATE CALC'S

SUMMARY OF RESULTS OF OPERATION

	Prior Year Ended 12/31/2001	TEST YEAR		TEST YEAR Income Adjustment for 9-10% Rate of Return	TEST YEAR Income Adjustment % Increase
		Actual 12/31/2002	Adjusted 12/31/2002		
Acct No. 461	\$99,169.72	\$111,617.11	\$111,617.11	\$111,617.11	
		Additional Revenue Required		\$81,000.00	72.57%
Revenue Deductions and Operating Expenses	\$96,235.52	\$93,676.29	\$93,676.29	\$93,676.29	
Operating Income/(Loss)	\$2,934.20	\$17,940.82	\$17,940.82	\$98,940.82	
Less Regulatory Commission Expense				(\$33,333.33)	
Other Income and Deductions				\$985.17	
Interest and Dividend Income	\$1,585.82	\$985.17	\$985.17	\$2,636.00	
Acquisition Adj. - Income	\$2,636.00	\$2,636.00	\$2,636.00	\$2,636.00	
Interest Expense	(\$728.22)	(\$10,262.92)	(\$15,660.14)	(\$15,660.14)	(a)
Total Other Income and Deductions	\$3,493.60	(\$6,641.75)	(\$12,038.97)	(\$12,038.97)	
Net Income	\$6,427.80	\$11,299.07	\$5,901.85	\$53,568.52	
Fair Value Rate Base		\$589,965.45	\$591,328.46	\$591,328.46	
Original Cost Less Depreciation	\$177,028.82				
Rate of Return	3.63%	1.92%	1.00%		9.06%

(a)

Three Year Average	
In 2003 Interest Is	\$16,191.23
In 2004 Interest Is	\$15,685.54
In 2005 Interest Is	\$15,103.64
AVERAGE	\$15,660.14

**TONTO HILLS UTILITY COMPANY
TEST YEAR ENDED DECEMBER 31, 2002
SUMMARY OF FAIR VALUE RATE BASE**

Gross Utility Plant in Service	\$761,852.25
Less: Accumulated Depreciation	\$171,886.80

Net Utility Plant	\$589,965.45
-------------------	--------------

Less:

Advances in Aid of Construction	
Contributions in Aid of Construction..Net Amortization	\$681.00
Customer Meter Deposits	\$9,665.53
Deferred Income Taxes & Credits	
Investment Tax Credits	

Plus:

Unamortized Finance Charges	
Deferred Tax Assets	
Allowance for Working Capital	\$11,709.54

TOTAL RATE BASE	\$591,328.46
------------------------	---------------------

PAGE 19.2

**TONTO HILLS UTILITY COMPANY
TEST YEAR ENDED DECEMBER 31, 2002
CALCULATION OF WORKING CAPITAL**

Cash Working Capital (1/8 of Allowance
Operation and Maintenance Expense)

\$93,676.29

\$11,709.54

Adjustment to Rate Base

\$11,709.54

PAGE 19.3

**TONTO HILLS UTILITY COMPANY
TEST YEAR ENDED DECEMBER 31, 2002
CALCULATION OF RATE CASE EXPENSE**

Rate Case Expense	\$100,000.00
Amortization Period (Years)	3
Annual Amortization Expens	\$33,333.33

Adjustment to Expense	\$33,333.33
------------------------------	--------------------

PAGE 19.4

Company Name: Tonto Hills Utility Company

Test Year Ended: December 31, 2002

**PROFIT & LOSS STATEMENT INCOME VS CALCULATED INCOME FOR 2002
PROPOSED RATES COMPARED TO CURRENT RATES**

GALLONAGE	NUMBER OF BILLS				Minimum \$/1,000 gals Average Consumption in Block	CURRENT AVERAGE \$ PER BILL	Proposed AVERAGE \$ PER BILL	% Increase Proposed Rates to Current	Blocks
	1st QUARTER	2nd QUARTER	3rd QUARTER	4th QUARTER					
0	10	9	11	9	\$40.00	\$40.00	\$70.00	75.00%	First Tier
To 1,000	20	9	17	7	\$6.80	\$43.40	\$75.31	73.50%	0 to 8,000 gallons
To 2,000	27	18	19	25	\$180.38	\$90.10	\$85.91	71.11%	Second Tier
To 3,000	43	26	23	32	\$908.10	\$157.00	\$96.51	69.30%	8,001 to 16,000 gallons
To 4,000	47	35	32	43	\$2,108.42	\$183.80	\$107.11	67.87%	
To 5,000	39	48	25	40	\$3,737.13	\$270.60	\$117.71	66.71%	
To 6,000	36	43	35	45	\$4,651.72	\$77.40	\$128.31	65.76%	
To 7,000	26	26	32	25	\$5,947.14	\$84.20	\$138.91	64.98%	
To 8,000	32	22	19	24	\$4,818.17	\$91.00	\$149.51	64.29%	
To 9,000	17	21	24	18	\$3,980.00	\$97.80	\$177.11	61.08%	
To 10,000	10	19	23	12	\$4,624.27	\$104.60	\$189.71	61.38%	
To 12,000	13	21	25	20	\$4,134.62	\$114.60	\$208.61	61.71%	
To 14,000	2	10	11	8	\$5,909.47	\$128.40	\$233.81	82.08%	
To 16,000	1	3	11	5	\$1,240.00	\$142.00	\$259.01	82.39%	
To 18,000	0	3	6	4	\$800.00	\$155.60	\$308.71	99.04%	
To 20,000	0	6	1	3	\$520.00	\$189.20	\$337.91	99.70%	
To 25,000	1	4	4	1	\$400.00	\$193.00	\$387.26	100.65%	
To 30,000	0	3	4	3	\$400.00	\$227.00	\$457.76	101.65%	
To 35,000	1	0	1	1	\$400.00	\$261.00	\$528.26	102.39%	
To 40,000	1	0	0	2	\$120.00	\$295.00	\$598.76	102.97%	
To 50,000	0	1	4	0	\$200.00	\$346.00	\$704.51	103.61%	
To 60,000	1	0	0	2	\$120.00	\$414.00	\$845.51	104.23%	
To 70,000	0	0	0	0	\$0.00	\$618.00	\$1,268.51	105.26%	
To 80,000	0	0	0	0	\$0.00	\$618.00	\$1,268.51	105.26%	
To 90,000	0	0	0	0	\$40.00	\$618.00	\$1,268.51	105.26%	
To 100,000	0	0	0	0	\$0.00	\$618.00	\$1,268.51	105.26%	
Over 100,000 (List actual gallons e.g., 120,000)					\$52,440.00	\$57,600.32	\$147.11	75.27%	
TOTAL BILLS	327	327	328	329	\$110,040.32	\$83.94	\$147.11	75.27%	

P&L Income	Billings
Calculated income	\$109,878.64
Difference	\$110,040.32
Percent	(\$161.68)
	-0.15%

Company Name: Tonto Hills Utility Company

Test Year Ended: 2002
December 31, 2002

PROPOSED RATES

GALLONAGE	NUMBER OF BILLS				TOTAL	Minimum \$/Month	Use Avg Consumption of Block \$/1,000 gls	Total Revenue \$/Mo Minimum + Block Rate	AVERAGE \$ PER BILL
	1st QUARTE	2nd QUARTE	3rd QUARTE	4th QUARTE					
0	10	9	11	9	39	\$70.00	\$10.60	\$2,730.00	\$70.00
1 To 1,000	20	9	17	7	53	\$3,710.00	\$10.60	\$3,991.18	\$75.31
1,001 To 2,000	27	18	19	25	89	\$6,230.00	\$10.60	\$7,645.57	\$85.91
2,001 To 3,000	43	26	23	32	124	\$8,680.00	\$10.60	\$11,968.66	\$96.51
3,001 To 4,000	47	35	32	43	157	\$10,990.00	\$10.60	\$16,815.53	\$107.11
4,001 To 5,000	39	48	25	40	152	\$10,640.00	\$10.60	\$17,891.21	\$117.71
5,001 To 6,000	36	43	35	45	159	\$11,130.00	\$10.60	\$20,400.54	\$128.31
6,001 To 7,000	28	26	32	25	109	\$7,630.00	\$10.60	\$15,140.68	\$138.91
7,001 To 8,000	32	22	19	24	97	\$6,790.00	\$10.60	\$14,502.01	\$149.51
8,001 To 9,000	17	21	24	18	80	\$5,600.00	\$12.60	\$14,168.50	\$177.11
9,001 To 10,000	10	19	23	12	64	\$4,480.00	\$12.60	\$12,141.20	\$189.71
10,001 To 12,000	13	21	25	20	79	\$5,530.00	\$12.60	\$16,479.90	\$208.61
12,001 To 14,000	2	10	11	8	31	\$2,170.00	\$12.60	\$7,248.00	\$233.81
14,001 To 16,000	1	3	11	5	20	\$1,400.00	\$12.60	\$5,180.13	\$259.01
16,001 To 18,000	0	3	6	4	13	\$910.00	\$14.10	\$4,026.19	\$309.71
18,001 To 20,000	0	6	1	3	10	\$700.00	\$14.10	\$3,379.07	\$337.91
20,001 To 25,000	1	4	4	1	10	\$700.00	\$14.10	\$3,872.57	\$387.26
25,001 To 30,000	0	3	4	3	10	\$700.00	\$14.10	\$4,577.57	\$457.76
30,001 To 35,000	1	0	1	1	3	\$210.00	\$14.10	\$1,584.77	\$528.26
35,001 To 40,000	1	0	0	2	3	\$210.00	\$14.10	\$1,796.27	\$598.76
40,001 To 50,000	0	1	4	0	5	\$350.00	\$14.10	\$3,522.54	\$704.51
50,001 To 60,000	1	0	0	2	3	\$210.00	\$14.10	\$2,536.52	\$845.51
60,001 To 70,000	0	0	0	0	0	\$0.00	\$14.10	\$0.00	
70,001 To 80,000	0	0	0	0	0	\$0.00	\$14.10	\$0.00	
80,001 To 90,000	0	0	1	0	1	\$70.00	\$14.10	\$1,268.51	\$1,268.51
90,001 To 100,000								\$0.00	
Over 100,000 (List actual gallons e.g., 120,000)						\$91,770.00		\$192,865.12	\$147.11 Avg
TOTAL BILLS	327	327	328	329	1,311			TOTAL	

P&L Income	\$192,617.11
Calculated Income	\$192,865.12
Difference	(\$248.01)
Percent	-0.13%

Current Avg	\$83.94
Proposed Avg	\$147.11
Percent Incrs	75.27%

DCI, INC.
Feb-02-04

Tonto Hills Utility Company Rate Comparison..Present to Proposed

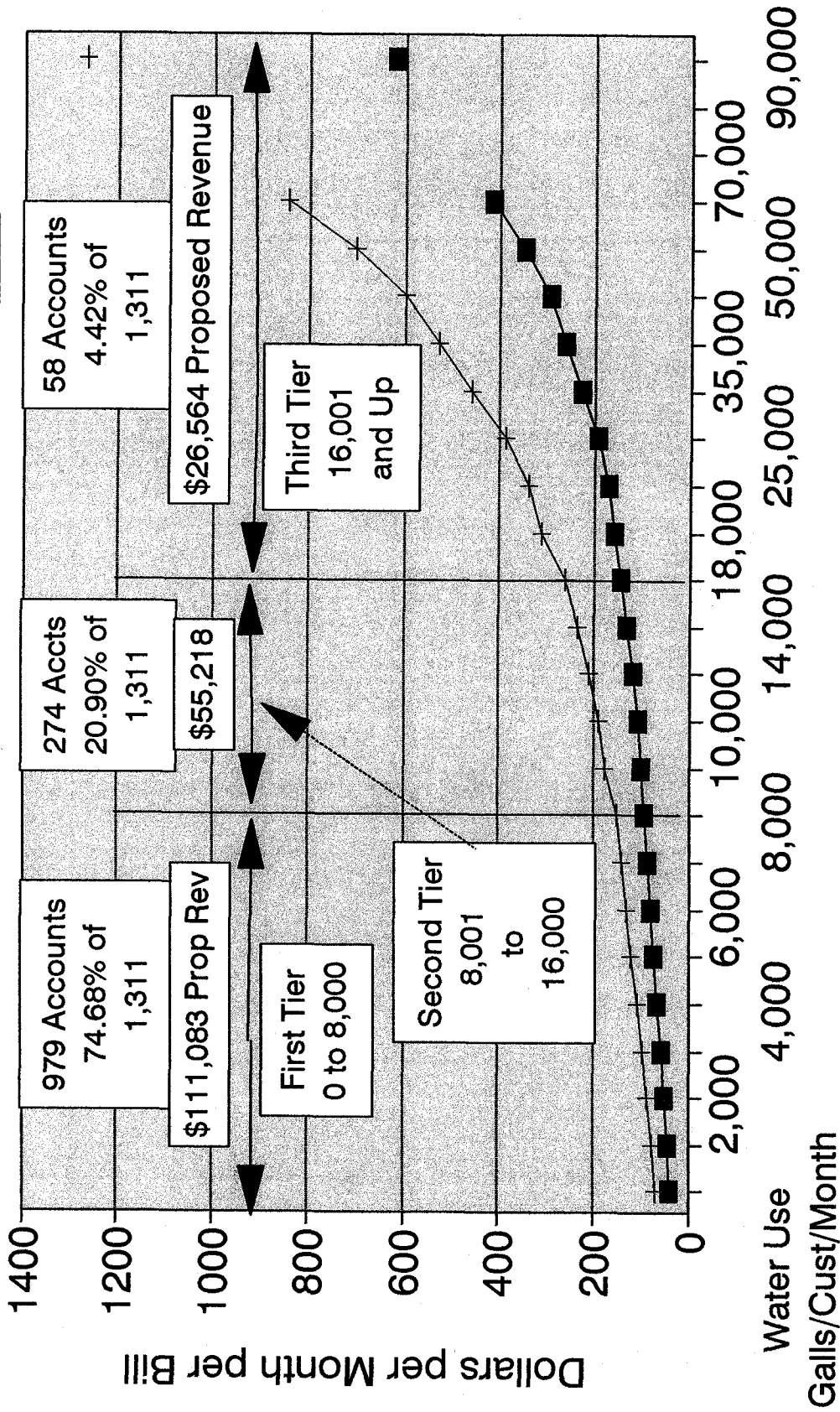

Current Rates
 Proposed Rates

COMPANY NAME:	TONTO HILLS UTILITY COMPANY	Test Year Ended:	December 31, 2002
---------------	-----------------------------	------------------	-------------------

CALCULATION OF DEPRECIATION EXPENSE

ADDITIONS PRESENTED IN BOLD ITALICS

Acct No	DESCRIPTION	Original Cost (1) <i>Column A</i>	Depreciation Percentage <i>Column B</i>	Depreciation Expense <i>Column C*</i>
301	Organization	\$385	0.00%	\$0
302	Franchises	\$0	0.00%	\$0
303	Land and Land Rights	\$35,282	N/A	\$0
	Water, Treat & Transport Rights			
	CAP Water	\$37,112	0.00%	\$0
	Environmental Work for CAP Water Transfer	\$28,529	0.00%	\$0
	COS Treat & Transport CAP Water ..30 af/yr	\$180,641	0.00%	\$0
	COS PS 94 Expansion for THUC Water	\$39,560	0.00%	\$0
	WATER, TREAT & TRANSPORT PAID BY WIFA (a)	\$285,842	0.00%	\$0
	COS PS 94 Balance from earnings	\$27,690	0.00%	\$0
	Brown&Caldwell search for wells	\$3,142	0.00%	\$0
	Dept of Reclamation not in WIFA	\$5,800	0.00%	\$0
	Legal for WIFA Loan	\$2,364	0.00%	\$0
	Hustead Engineering..Previous Rate Case	\$16,987	0.00%	\$0
	DCI, INC....Previous Rate Case	\$15,000	0.00%	\$0
	Hustead Engineering..Additional Services	\$22,012	0.00%	\$0
	DCI, INC....Additional Services	\$34,100	0.00%	\$0
	SUM OF WATER, TREAT & TRANSPORT PAID FROM EARNINGS (a)	\$127,095	0.00%	\$0
	TOTAL WATER, TREAT & TRANSPORT PAID FROM WIFA AND EARNINGS (a)	\$412,937	0.00%	\$0
304	Structures and Improvements	\$2,277	5.00%	\$114
307	Wells and Springs	\$50,197	5.00%	\$2,510
311	Pumping Equipment	\$47,247	5.00%	\$2,362
320	Water Treatment Equipment	\$26,269	5.00%	\$1,313
320.1	Water Treatment Plants	\$0	0.00%	\$0
320.2	Solution Chemical Feeders	\$0	0.00%	\$0
330	Distribution Reservoirs and Standpipes	\$0	0.00%	\$0
330.1	Storage Tanks	\$12,200	5.00%	\$610
330.2	Pressure Tanks	\$0	0.00%	\$0
331	Transmission and Distribution Mains	\$136,063	5.00%	\$6,803
333	Services..Staff Change in Decision 61109	\$14,598	5.00%	\$730
334	Meters and Meter Installations..Staff Chg ..61109	\$3,650	5.00%	\$183
335	Hydrants	\$1,325	5.00%	\$66
336	Backflow Prevention Devices	\$0	0.00%	\$0
339	Pther Plant and Misc. Equipment	\$0	0.00%	\$0
340	Office Furniture and Equipment	\$6,231	5.00%	\$312
340.1	Computers & Software	\$0	0.00%	\$0
341	Transportation Equipment	\$0	0.00%	\$0
343	Tools, Shop and Garage Equipment	\$0	0.00%	\$0
344	Laboratory Equipment	\$0	0.00%	\$0
345	Power Operated Equipment	\$0	0.00%	\$0
346	Communication Equipment	\$0	0.00%	\$0
347	Miacellaneous Equipment	\$14,150	5.00%	\$707
348	Other Tangible Plant	\$0	0.00%	\$0
	TOTAL FIXED ASSETS	\$314,207	0.00%	\$0
	TOTAL WATER PLANT	\$782,910		\$15,710

(a) THUC holds the rights to capacity in these facilities, but the assets are owned by others

Note: Use Test Year ending balances for column 1, and approved depreciation rates from the prior rate case in column 2.

*Column C = Column A x Column B

COMPANY NAME:

TONTON HILLS UTILITY COMPANY

Test Year Ended:

December 31, 2002

BALANCE SHEET

Acct. No.	ASSETS	BALANCE AT BEGINING OF TEST YEAR	BALANCE AT END OF TEST YEAR	
	CURRENT AND ACCRUED ASSETS			
131	Cash			
131.1	Checking	\$13,877	\$7,511	
131.2	Compass Transfer Account	\$1,162	\$2,445	
131.3	Founders Money Market	\$62,540	\$54,025	
131.3	Founders Money Market..Less Reduced Income	(\$16,007)	(\$26,582)	
131.3	Founders Money Market..Less Debt Service	(\$4,994)	(\$9,989)	
	TOTAL CHECKING/SAVINGS	\$56,578	\$27,410	
134	Working Funds	\$0	\$0	
135	Temporary Cash Investments	\$0	\$0	
141	Customer Accounts Receivable	\$7,227	\$8,822	
146	Notes/Receivables from Associated Companies	\$0	\$0	
151	Plant Material and Supplies	\$0	\$0	
162	Prepayments (Expenses-other)	\$0	\$10,440	
174	Miscellaneous Current and Accrued Assets (McVety	\$151	\$151	
	TOTAL CURRENT AND ACCRUED ASSETS	\$63,956	\$46,823	
	FIXED ASSETS			
101	Utility Plant in Service	\$341,241	\$349,874	*
	WATER, TREAT & TRANSPORT PAID BY WIFA (a)		\$285,842	*
	CAP Water	\$4,027		
	Environmental Work for CAP Water Transfer	\$28,361		
	WATER, TREAT & TRANSPORT PAID FROM EARNINGS (a)		\$127,095	*
103	Property Held for Future Use	\$0	\$0	
105	Construction Work in Progress	\$0	\$0	
108	Accumulated Depreciation - Utility Plant ("AD-UP")	(\$171,887)	(\$171,887)	**
121	Non-Utility Property	\$0	\$0	Debt Svc
122	Accumulated Depreciation - Non Utility("AD-NU")	\$0	\$0	2000
	TOTAL FIXED ASSETS	\$201,742	\$590,923	\$2,913.33
				2001
174	MISCELLANEOUS CURRENT and ACCRUED ASSE			\$4,994.28
	Misc Prepaid Loan	\$4,062	\$4,062	2002
	Prepaid Misc Non-Utility Income	\$12,344	\$35,352	\$4,994.28
	Debt Service Reserve	\$7,908	\$12,902	\$12,901.89
	TOTAL MISC CURRENT and ACCRUED ASSETS	\$24,314	\$52,316	Total
186	MISCELLANEOUS DEFERRED DEBITS			
	Acquisition Adjustment (Net)	(\$14,062)	(\$11,426)	
	TOTAL ASSETS	\$275,949	\$678,636	
	(a) THUC holds rights to capacity in these facilities, but the assets are owned by others			

Note: Total Assets on this page should equal the sum of Total Liabilities and Total Capital on page 22. Also, numbers in parentheses should be subtracted. For example, Accounts 108 and 122 should be subtracted from the Total Fixed Assets.

*Must equal page 15, original cost

** Must equal page 15, accumulated depreciation

COMPANY NAME: TONTO HILLS UTILITY COMPANY	Test Year Ended: December 31, 2002
---	--

BALANCE SHEET (CONTINUED)

Acct. No.	LIABILITIES	BALANCE AT BEGINING OF TEST YEAR	BALANCE AT END OF TEST YEAR	
	CURRENT LIABILITIES			
231	Accounts Payable	\$0	\$0	
232	Notes Payable (Current Portion)	\$0	\$0	
234	Notes/Accounts Payable to Associated Companies	\$0	\$0	
235	Customer Deposits (Meters)	\$9,666	\$9,666	
	CAP Water Project	\$0	\$1	
236	Accrued Taxes	\$1,658	\$1,758	
237	Accrued Interest	\$208	\$0	
241	Miscellaneous Current and Accrued Liabilities	\$0	\$208	
	TOTAL CURRENT LIABILITIES	\$11,531	\$11,632	
	LONG-TERM DEBT (Over 12 Months)			
224	Long-Term Notes and Bonds (W.I.F.A.)	\$20,261	\$265,965	DCI
	DEFERRED CREDITS			
251	Unamortized Premium on Debt	\$0	\$0	
252	Advances in Aid of Construction	\$0	\$0	
255	Accumulated Deferred Investment Tax Credits	\$0	\$0	
271	Contributions in Aid of Construction - Fire Hydrants	\$681	\$681	
272	Less: Amortization of Contributions	\$0	\$0	
281	Accumulated Deferred Income Tax	\$0	\$0	
	TOTAL DEFERRED CREDITS	\$681	\$681	2000 \$4,295.71
	TOTAL LIABILITIES	\$32,474	\$278,278	2001 \$164.37
	CAPITAL ACCOUNTS			Debt Svc Erngs
201	Common Stock Issued	\$66,000	\$66,000	2001
211	Paid in Capital in Excess of Par Value	\$0	\$0	\$7,666.34
215	Retained Earnings	\$233,922	\$256,356	2002
215.1	Earnings invested in Capital..not paid by WIFA	\$0	\$127,095	\$7,750.68
215.2	Earnings invested in Capital by Paying ON WIFA	\$12,126	\$19,877	\$19,877.10
	Partner Distributions	(\$75,000)	(\$80,222)	Total
	Net Income	\$6,428	\$11,252	
218	Proprietary Capital (Sole Props and Partnerships)	\$0		
	TOTAL CAPITAL	\$243,476	\$400,358	
	TOTAL LIABILITIES AND CAPITAL	\$275,949	\$678,636	

Note: Account 272 should be subtracted from the Total Deferred Credits.

* Must equal page 24, Total Advances in Aid of Construction

** Must equal page 25, Total Advances

Company Name: Tonto Hills Utility Company	Test Year Ended: December 31, 2002
--	---------------------------------------

SUPPLEMENTAL FINANCIAL DATA

Long-Term Debt

	Loan #1*	Loan #2*	Loan #3*	Loan #4*
Date Issued	12-17-99			
Source of Loan	Water Infrastructure Financial Authority			
Reason for Loan	CAP WATER SOURCE			
Dollar Amount Issued	\$285,841.60			
Net Proceeds	\$285,841.60			
Amount Outstanding	\$265,964.50			
Date of Maturity	01-01-2020			
Interest Rate	6.2%			
Current Year Interest	\$10,262.92			
Current Year principal	\$7,750.68			
Authority Granted By ACC Decision No.	62286			

A.R.S. 40-301 requires ACC approval of long-term debt. If the Commission has not approved any of the above loans, then please submit an application requesting approval of loans.

Meter Deposit Balance - Test Year	\$ 9,665.53
Meter Deposits Refunded During the Test Year	\$

List all bonds, notes, loans, and other types of indebtedness in which the proceeds were used in the provision of public utility service. Indebtedness incurred for personal uses by the owner of the utility should not be listed.

ADVANCES IN AID OF CONSTRUCTION (Acct. 252)²

	Additions During Year	Refunds During Year	
Balance Per Prior Decision	N/A	N/A	\$ 0.00
Year_____	\$	\$	
Year_____	\$	\$	
Year_____	\$	\$	
Year_____	\$	\$	
Year_____	\$	\$	
Year_____	\$	\$	
Year_____	\$	\$	
Year_____	\$	\$	
Year_____	\$	\$	
Year_____	\$	\$	
Year_____	\$	\$	
Year_____	\$	\$	
Year_____	\$	\$	
Year_____	\$	\$	
Year_____	\$	\$	
Total of Additions	\$	N/A	
Total of Refunds	N/A	\$	
Total Advances in Aid of Construction	N/A	N/A	\$ 0.00

Note: Prior Decision refers to the balances per the prior Staff Report as adjusted per the final Commission Decision.

** Total Advances in Aid of Construction = Balance Per Prior Decision + Total Additions - Total Refunds (cross reference this to the Balance Sheet on page 22)*

² *Advances in Aid of Construction refers to the following:*

- (1) Refundable amounts received from a new customer to cover the cost of a meter and piping from the building to the meter and the associated installation.*
- (2) Refundable amounts received from a customer or a developer for mains, valves, fittings, and additional facilities required to provide pressure, storage, or water supply pursuant to a main extension agreement.*

GROSS CONTRIBUTIONS IN AID OF CONSTRUCTION (Acct. 271)³

Balance Per Prior Decision	N/A	\$ 0.00
Additions Year	\$	NO INFORMATION AVAILABLE
Additions Year	\$	
Additions Year	\$	
Additions Year	\$	
Additions Year	\$	
Additions Year	\$	
Additions Year	\$	
Additions Year	\$	
Additions Year	\$	
Additions Year	\$	
Additions Year	\$	
Additions Year	\$	
Additions Year	\$	
Additions Year	\$	
Total Additions	N/A	\$ 681.00
Balance at Test Year End	N/A	\$ 681.00

**NO INFORMATION
AVAILABLE**

Note: Prior Decision refers to the balances per the prior Staff Report as adjusted per the final Commission Decision.

** Balance at Test Year End = Balance Per Prior Decision + Total Additions (cross reference this to the Balance Sheet on page 22)*

³ *Contributions in Aid of Construction refers to the following:*

- (1) Non-refundable money, services, or property received for use in the provision of utility service from any source that is provided at no cost and interest free.*
- (2) Unfunded balances of expired advance contracts reclassified from Advances in Aid of Construction.*

BILL COUNT INSTRUCTIONS

A quarterly Bill Count must be provided for each of the meter sizes the Company had in service during the Test Year. If you had more than one meter size in service, reproduce the forms on pages 27 through 31, inclusive, so that you will submit one set of Bill Count forms (i.e. one Bill Count for each quarter and a Bill Count Summary), for each meter size. An item such as a metered standpipe would be considered to be a different size meter, since it may have a different tariff rate than the other size meters.

A Bill Count Summary sheet is provided on page 31. Please note that each bill over 100,000 gallons should be shown separately. The number of bills in each line will be added to produce a total of all bills at the bottom of the page.

The first step in producing the Bill Count is to collect all monthly bills rendered for metered water sales during the 12 months of the Test Year. The collection of bills must include bills to part-time customers and to customers who are no longer on the system, but who were on the system for any part of the Test Year.

Only include bills for water sold during the Test Year. For example, assume that the Test Year runs from January 1st to December 31st (calendar year) and you normally bill on January 5th. The bill sent out at that time would cover December 1st through 31st usage of the prior year and should not be included. The first billing to be used for the year would be the February 5th billing and the last billing to be used would be the billing of January 5th of the succeeding year.

Sort the bills by each quarter, by meter size, so that a separate bill count is produced for each three-month period by meter size. On each quarterly Bill Count sheet, place a tally for each bill in the appropriate gallonage range. After tallying each bill, add the tallies in each gallonage range and report the tally totals in the column provided.

Note: For explanation of any of the above, please contact the Chief of Accounting and Rates at 602-542-0743.

Company Name: Tonto Hills Utility Company	Test Year Ended:...2002
Meter Size: 3/4 inch	1st Quarter Ended: March 31, 2002

GALLONAGE RANGE	NUMBER OF BILLS			
	Dec 01	Jan 02	Feb 02	TOTAL BILLS FOR 1ST QUARTER
Use in Month of:	Jan 02	Feb 02	Mar 02	
Billed in Month of:				
0	3	4	3	10
1 To 1,000	10	5	5	20
1,001 To 2,000	9	9	9	27
2,001 To 3,000	18	14	11	43
3,001 To 4,000	13	17	17	47
4,001 To 5,000	13	10	16	39
5,001 To 6,000	13	11	12	36
6,001 To 7,000	9	10	7	26
7,001 To 8,000	7	12	13	32
8,001 To 9,000	4	6	7	17
9,001 To 10,000	4	2	4	10
10,001 To 12,000	2	8	3	13
12,001 To 14,000	1	0	1	2
14,001 To 16,000	1	0	0	1
16,001 To 18,000	0	0	0	0
18,001 To 20,000	0	0	0	0
20,001 To 25,000	1	0	0	1
25,001 To 30,000	0	0	0	0
30,001 To 35,000	0	0	1	1
35,001 To 40,000	1	0	0	1
40,001 To 50,000	0	0	0	0
50,001 To 60,000	0	1	0	1
60,001 To 70,000	0	0	0	0
70,001 To 80,000	0	0	0	0
80,001 To 90,000	0	0	0	0
90,001 To 100,000	0	0	0	0
Over 100,000 (List actual gallons e.g., 120,000)				
Total Bills	109	109	109	327

Company Name: Tonto Hills Utility Company	Test Year Ended:...2002
Meter Size: 3/4 inch	2nd Quarter Ended: June 30, 2002

GALLONAGE RANGE	NUMBER OF BILLS			
	Use in Month of: Billed in Month of:	Mar 02 April 02	April 02 May 02	May 02 June 02
0	3	3	3	9
1 To 1,000	2	3	4	9
1,001 To 2,000	6	7	5	18
2,001 To 3,000	11	9	6	26
3,001 To 4,000	14	11	10	35
4,001 To 5,000	19	15	14	48
5,001 To 6,000	12	16	15	43
6,001 To 7,000	12	6	8	26
7,001 To 8,000	5	10	7	22
8,001 To 9,000	9	5	7	21
9,001 To 10,000	6	8	5	19
10,001 To 12,000	7	5	9	21
12,001 To 14,000	1	5	4	10
14,001 To 16,000	0	0	3	3
16,001 To 18,000	0	2	1	3
18,001 To 20,000	2	0	4	6
20,001 To 25,000	0	3	1	4
25,001 To 30,000	0	1	2	3
30,001 To 35,000	0	0	0	0
35,001 To 40,000	0	0	0	0
40,001 To 50,000	0	0	1	1
50,001 To 60,000	0	0	0	0
60,001 To 70,000	0	0	0	0
70,001 To 80,000	0	0	0	0
80,001 To 90,000	0	0	0	0
90,001 To 100,000	0	0	0	0
Over 100,000 (List actual gallons e.g., 120,000)				
Total Bills	109	109	109	327

Company Name: Tonto Hills Utility Company	Test Year Ended:...2002
Meter Size: 3/4 inch	3rd Quarter Ended: Sept 30, 2002

GALLONAGE RANGE	NUMBER OF BILLS			
	Use in Month of: June 02	July 02	Aug 02	TOTAL BILLS FOR 3rd QUARTER
Billed in Month of:	July 02	Aug 02	Sept 02	
0	4	3	4	11
1 To 1,000	5	7	5	17
1,001 To 2,000	4	7	8	19
2,001 To 3,000	9	9	5	23
3,001 To 4,000	5	17	10	32
4,001 To 5,000	11	5	9	25
5,001 To 6,000	8	12	15	35
6,001 To 7,000	11	10	11	32
7,001 To 8,000	4	8	7	19
8,001 To 9,000	11	8	5	24
9,001 To 10,000	12	3	8	23
10,001 To 12,000	8	8	9	25
12,001 To 14,000	4	5	2	11
14,001 To 16,000	7	1	3	11
16,001 To 18,000	3	2	1	6
18,001 To 20,000	0	0	1	1
20,001 To 25,000	1	1	2	4
25,001 To 30,000	0	2	2	4
30,001 To 35,000	1	0	0	1
35,001 To 40,000	0	0	0	0
40,001 To 50,000	1	1	2	4
50,001 To 60,000	0	0	0	0
60,001 To 70,000	0	0	0	0
70,001 To 80,000	0	0	0	0
80,001 To 90,000	0	0	1	1
90,001 To 100,000	0	0	0	0
Over 100,000 (List actual gallons e.g., 120,000)				
Total Bills	109	109	110	328

Company Name: Tonto Hills Utility Company	Test Year Ended:...2002
Meter Size: 3/4 inch	4th Quater Ended: Dec 31, 2002

GALLONAGE RANGE	NUMBER OF BILLS			
	Use in Month of: Billed in Month of:	Sept 02 Oct 02	Oct 02 Nov 02	Nov 02 Dec 02
0	3	3	3	9
1 To 1,000	4	3	0	7
1,001 To 2,000	6	8	11	25
2,001 To 3,000	10	12	10	32
3,001 To 4,000	12	14	17	43
4,001 To 5,000	12	12	16	40
5,001 To 6,000	17	14	14	45
6,001 To 7,000	9	10	6	25
7,001 To 8,000	10	6	8	24
8,001 To 9,000	6	6	6	18
9,001 To 10,000	1	3	8	12
10,001 To 12,000	9	7	4	20
12,001 To 14,000	2	5	1	8
14,001 To 16,000	2	1	2	5
16,001 To 18,000	2	2	0	4
18,001 To 20,000	1	1	1	3
20,001 To 25,000	1	0	0	1
25,001 To 30,000	2	0	1	3
30,001 To 35,000	0	1	0	1
35,001 To 40,000	2	0	0	2
40,001 To 50,000	0	0	0	0
50,001 To 60,000	0	1	1	2
60,001 To 70,000	0	0	0	0
70,001 To 80,000	0	0	0	0
80,001 To 90,000	0	0	0	0
90,001 To 100,000	0	0	0	0
Over 100,000 (List actual gallons e.g., 120,000)				
Total Bills	111	109	109	329

Company Name: Tonto Hills Utility Company	Test Year Ended:...2002
Meter Size: 3/4 inch	

GALLONAGE RANGE	BILL COUNT SUMMARY				
	1st Qtr	2nd Qtr	3rd Qtr	4th Qtr	TOTAL
0	10	9	11	9	39
1 To 1,000	20	9	17	7	53
1,001 To 2,000	27	18	19	25	89
2,001 To 3,000	43	26	23	32	124
3,001 To 4,000	47	35	32	43	157
4,001 To 5,000	39	48	25	40	152
5,001 To 6,000	36	43	35	45	159
6,001 To 7,000	26	26	32	25	109
7,001 To 8,000	32	22	19	24	97
8,001 To 9,000	17	21	24	18	80
9,001 To 10,000	10	19	23	12	64
10,001 To 12,000	13	21	25	20	79
12,001 To 14,000	2	10	11	8	31
14,001 To 16,000	1	3	11	5	20
16,001 To 18,000	0	3	6	4	13
18,001 To 20,000	0	6	1	3	10
20,001 To 25,000	1	4	4	1	10
25,001 To 30,000	0	3	4	3	10
30,001 To 35,000	1	0	1	1	3
35,001 To 40,000	1	0	0	2	3
40,001 To 50,000	0	1	4	0	5
50,001 To 60,000	1	0	0	2	3
60,001 To 70,000	0	0	0	0	0
70,001 To 80,000	0	0	0	0	0
80,001 To 90,000	0	0	1	0	1
90,001 To 100,000	0	0	0	0	0
Over 100,000 (List actual gallons e.g., 120,000)					
Total Bills	327	327	328	329	1311

NOTIFICATION

**TONTO HILLS UTILITY COMPANY
11802 E. BLUE WASH ROAD
CAVE CREEK, AZ 85331**

Docket Control Center
Arizona Corporation Commission
1200 W. Washington
Phoenix, Az 85007-2996

March 31, 2004

Re: Tonto Hills Utility Company Rate Case
Test Year Ending December 31, 2002
Docket Number: W-02483A-04-_____
Notification of Customers
Page 32

Each customer was mailed the following package that contained:

- A transmittal Memo
- A CUSTOMER NOTIFICATION
- Page 9 setting forth the Current and Proposed Rates and Charges
- Page 9A setting forth the Proposed Non-Refundable Hook-Up Fee
- Page 11 setting forth the Current and Proposed Service Charges
- A copy of the Tonto Hills Utility Company History

This package was mailed to each customer on March 31, 2004.

A copy of the above package is attached to this letter.

Sincerely,

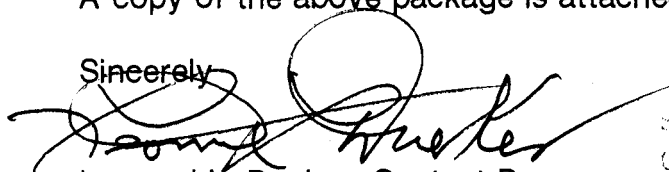

Leonard L. Dueker, Contact Person
President of DCI, INC.

State of Arizona

County of Maricopa

On 31 th day of March, 2004
Leonard L. Dueker (name of signer), personally
appeared before me, whom I know personally
to be the person who signed the above/attached
document and he/she proved he/she signed it.

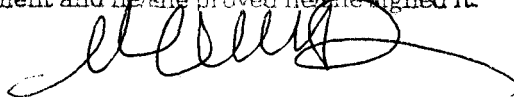

NOTARY SEAL

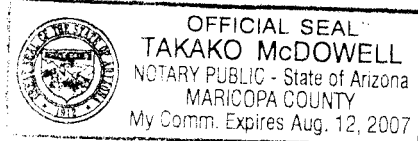

Memo

To: All Customers
From: Don Unthank

Date: March 31, 2004

Re: Application for an Increase in Rates and a Hook-up Fee

Dear Customers:

This Application to the Arizona Corporation Commission culminates 7 years of patience, persistence, optimism, assistance from others, sometimes pessimism, and always a lot of work to obtain the 100 year non-groundwater supply for Tonto Hills Utility Company.

I am enclosing the following:

1. The Customer Notification form required to be sent to you by the Arizona Corporation Commission.
2. A copy of the TONTO HILLS UTILITY COMPANY HISTORY. This begins with the Formation of the Company and then goes on to detail the efforts of the staff and consultants expended during the 7 year period to obtain an assured water supply.

Thank you for your patience in the long process leading to this conclusion.

Thank You

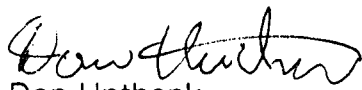
Don Unthank

CUSTOMER NOTIFICATION

TONTO HILLS UTILITY COMPANY has applied to the Arizona Corporation Commission for an adjustment in rates. The current rates have been in effect since September, 1998. An increase in the rates is necessary at this time due to the Obtainment of a CAP Water Supply.

Based on the Company's un-audited Test Year results, Tonto Hills Utility Company realized an operating income of \$17,893 in 2002.

The Company is requesting a revenue increase of \$81,000 or 72.57% of total revenues. Please see the attached pages 9 and 11 of the Company's application for the current and proposed rates.

In addition the Company is requesting a NON-REFUNDABLE, ONE TIME HOOK-UP FEE TO BE PAID WITH THE APPLICATION FOR THE SETTING OF A NEW METER FOR A NEW CUSTOMER. *It will not apply to existing customers.* The Fee being requested is \$3,000 per 5/8 by 3/4 inch meter. This Fee will be used to pay the City of Scottsdale for the additional Treat and Transport Capacity through its system to deliver the water required by the new customer.

See attached page 9A.

The Application is available for inspection during regular business hours at the offices of the Commission in Phoenix at 1200 West Washington Street and at the office of Tonto Hills Utility Company at 11802 E. Blue Wash Road in Tonto Hills. Please be advised that the rates and charges ultimately approved by the Commission may be higher or lower than the rates and charges requested in the Application.

Customer input is an important part of the Commission's analysis of the requested adjustment and is a factor in determining whether a hearing will be conducted. Customers should bring to the Commission's attention any question or concerns related to the Company's Application, including service, billing procedures or other factors important in determining the reasonableness of charges. Customers may have the right to intervene in this matter. Customers wishing to communicate with the Commission, or request information on intervention in the proceeding, should contact the Commission's Consumer Services Section at 800-222-7000 (if located outside the Phoenix local calling area) or 602-542-4251 in the Phoenix local calling area.

Customers are advised that the Commission may act upon the Application without a hearing. Regardless of whether a formal hearing is held, customer comments submitted in writing will be placed in the office file, which the Commission reviews prior to making its final decision on the Application. It is important that Customers contact the Commission within 15 days of the receipt of this notice so that the Commission's Staff can consider customer comments and concerns in developing its recommendations to the Commission.

CURRENT AND PROPOSED RATES AND CHARGES

CUSTOMER CLASS: Residential Commercial Industrial

Irrigation All Other, specify _____

CURRENT RATES

PROPOSED RATES

MINIMUM OR SERVICE CHARGES	\$ GALLONS	\$ GALLONS
5/8" x 3/4	40.00 for 0.00	70.00 for 0.00
3/4" Meter	40.00 for 0.00	70.00 for 0.00
1" Meter	90.00 for 0.00	158.00 for 0.00
1-1/2" Meter	115.00 for 0.00	200.00 for 0.00
2" Meter	155.00 for 0.00	270.00 for 0.00
3" Meter		490.00 for 0.00
4" Mete		630.00 for 0.00
6" Meter		840.00 for 0.00

GALLONS IN EXCESS OF MINIMUM	
Commodity Charge in Excess of Minimum (Charge Per 1,000 Gallons)	
First Tier	\$10.60
Second Tier	\$12.60
Third Tier	\$14.10
FLAT RATE	

Current Rates

Proposed Rates

Rate	Gallons	Rate	Gallons
\$ 6.80	Up to ALL	\$ 10.60	Up to 8,000
\$	to	\$ 12.60	8,001 to 16,000
\$	Over	\$ 14.10	Over 16,000
\$	Per Month	\$	Per Month

Note: If rates and charges vary across customer classes, duplicate the form and complete one for each rate class. (e.g., residential, commercial) unless "All" is checked.

DCI, INC.
Feb-02-04

Tonto Hills Utility Company Rate Comparison..Present to Proposed

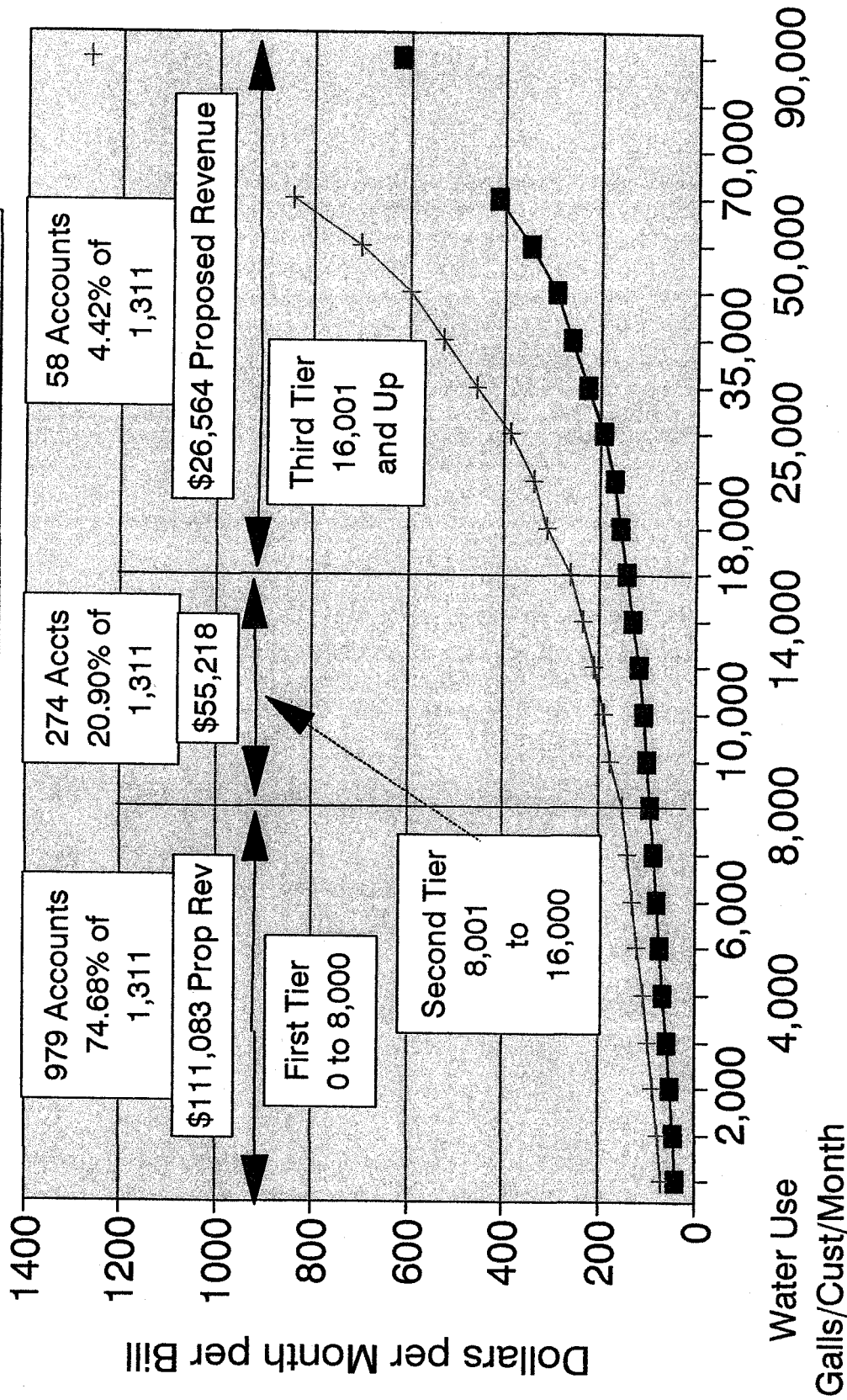

■ Current Rates
+ Proposed Rates

Company Name: Tonto Hills Utility Company	Test Year Ended: December 31, 2002
---	--

CURRENT AND PROPOSED RATES AND CHARGES (Continued)

NON-REFUNDABLE OFF-SITE FACILITIES HOOK UP FEE

TONTO HILLS UTILITY COMPANY CURRENTLY OWNS 30 ACRE FEET PER YEAR OF
 TREAT AND TRANSPORT CAPACITY
 FOR WHICH IT PAID THE CITY OF SCOTTSDALE \$180,641.41

AS GROWTH OCCURS AND ADDITIONAL TREAT AND TRANSPORT CAPACITY IS REQUIRED,
 TONTO HILLS UTILITY COMPANY MAY PURCHASE ADDITIONAL CAPACITY
 IN 1 ACRE FOOT PER YEAR INCREMENTS AS REQUIRED,
 UP TO A MAXIMUM OF 71 ACRE FEET PER YEAR.

THE PROPOSED NON-REFUNDABLE, ONE TIME HOOK-UP FEE WILL BE USED EXCLUSIVELY TO PURCHASE
 THE ADDITIONAL TREAT AND TRANSPORT CAPACITY THAT WILL BE REQUIRED TO SERVE
 THE NEW CUSTOMERS

See Section D for City of Scottsdale Development Fees

**NON-REFUNDABLE, ONE TIME, TONTO HILLS HOOK-UP FEE, TO BE PAID
 WITH THE APPLICATION FOR THE SETTING OF A NEW METER,
 AND PAID IN ADDITION TO THE SERVICE LINE AND METER
 INSTALLATION CHARGES DETAILED ON PAGE 11**

Meter Siz		HOOK-UP FEE
5/8" by 3/4"	Size Factor 1	\$3,000
3/4"	Size Factor 1.50	\$4,500
1"	Size Factor 2.5	\$7,500
1-1/2"	Size Factor 5	\$15,000
2"	Size Factor 8	\$24,000
3"	Size Factor 17.5	\$52,500
4"	Size Factor 30	\$90,000
6"	Size Factor 62	\$186,000

Company Name: Tonto Hills Utility Company	Test Year Ended: 12/31/2002
--	--------------------------------

CURRENT AND PROPOSED SERVICE CHARGES

CUSTOMER CLASS: Residential Commercial Industrial
 Irrigation All Other, specify _____

SERVICE LINE AND METER INSTALLATION CHARGES	CURRENT CHARGES	PROPOSED CHARGES
5/8" x 3/4" Meter	\$ 600.00	\$ 800.00
3/4" Meter	\$ 600.00	\$ 800.00
1" Meter	\$ 700.00	\$ 900.00
1-1/2" Meter	\$ 850.00	\$ 1,100.00
2" Turbo Meter	\$ 1,150.00	\$ 1,500.00
2" Compound Meter	\$ 1,720.00	\$ 2,245.00
4" Meter		\$ -
6" Meter		\$ -

Establishment	\$ 15.00	\$ 15.00
Establishment (after hours)	\$ 25.00	\$ 25.00
Reconnection (delinquent)	\$ 25.00	\$ 25.00
Reconnection (delinquent) after hours	\$ -	\$ -
Meter Test	\$ 35.00	\$ 35.00
Deposit	*	*
Deposit Interest	**	**
Re-Establishment (within 12 months)	***	***
NSF Check	\$ 25.00	\$ 25.00
Deferred Payment	1.50%	1.50%
Meter Re-read (If Correct)	\$ 15.00	\$ 15.00
Meter Test (Svc Chg Plus Cost of Bnch Test)	\$ 35.00	\$ 35.00

Note: If rates and charges vary across customer classes, duplicate the form and complete one for each rate class. (e.g., residential, commercial) unless "All" is checked.

* Per Commission Rule AAC R-14.2.403.B.7

** Per Commission Rule AAC R14.2.403.B.3

*** Number of months off system times the monthly minimum per Commission Rule AAC R.14.2.403.D

TONTO HILLS UTILITY COMPANY HISTORY

FORMATION

The Tonto Hills Utility Company (THUC) is a private utility, subject to regulation by the Arizona Corporation Commission. It serves an existing 40-year-old subdivision in Maricopa County lying immediately adjacent to the City of Scottsdale (COS). It contains 205 lots, with 109 lots connected and served.

The utility was formed by the sub-divider of the land. Because of problems with water quality, and for other reasons he became disenchanted with owning the company, and refused to maintain and/or improve the system. Some of the homeowners in the development purchased the company in order to provide an adequate water supply to the development. Since acquisition they have made improvements to the system, including equipment to treat the water from one of the wells for radiochemicals.

WATER SUPPLY

There were two wells, both of which are located on United States Forest Land, but only one well is now operable and has a capacity of 11 gpm. The well has a high level of radioactivity that must be removed by treatment before delivery to the system.

Recent droughts, together with additional new home construction, resulted in summer demands greater than the well capacity and therefore requiring the trucking of water from an adjacent system.

RISK

With only one very small well providing water for 109 dwelling units, the homes were at very great risk of having only hauled water as their supplemental supply, or if the well is no longer in service their only supply.

OTHER WELLS

Tonto Hills Utility Company (THUC) retained the engineering firm of Brown and Caldwell to prepare a Well Feasibility Report for provision of additional water supply from new wells.

Following this THUC made a request to the Tonto National Forest to drill additional wells on the National Forest.

In a letter dated July 3, 1996 the Forest Service disapproved the application.

CITY OF SCOTTSDALE AGREEMENT

In 1996 DCI, INC. began negotiating with the City of Scottsdale for an agreement to treat and transport water from the CAP Canal through its system to the Tonto Hills Utility System. The initial contacts made it clear that Tonto Hills Utility Company had to provide its own water supply.

MORATORIUM

At this point THUC applied to the Corporation Commission for and received a moratorium (July 2, 1997—DECISION NO. 60266) on new connections to the system until it has demonstrated that it has adequate production to meet demand.

SEARCH FOR CAP WATER

THUC continued to look for CAP Water that could be transferred to THUC. One was the SUNRISE Water Company. In response to an inquiry by DCI, INC., SUNRISE Water Company on August 4, 1997 informed DCI, INC. that they were not interested in transferring their CAP Allocations of either SUNRISE Water Company or WEST END Water Company.

In 1998 THUC's consultants became aware of BHP Copper's desire to transfer its rights to CAP Water to others and worked with the Representatives of BHP Copper, Arizona Department of Water Resources, CAWCD, Bureau of Reclamation, City of Scottsdale, the Town of Carefree and THUC to have the BHP allocation assigned in the following proportions:

Town of Carefree	900 acre-feet
Tonto Hills Utility Company	71 acre feet
City of Scottsdale	<u>1,300 acre-feet</u>
TOTAL	2,271 acre-feet

The 71-acre feet requested by THUC is the total projected ultimate demand of THUC.

TEMPORARY CONNECTION TO THE CITY OF SCOTTSDALE SYSTEM

The one well was not keeping up with the demand of the system, and THUC was hauling water. Because of this, DCI, INC. on August 11, 1999, made a request of the City of Scottsdale to install a construction meter on a fire hydrant near the tank of THUC until the permanent connection to the City's system had been installed and was operational.

The City gave its permission, and a 2-inch PVC line was laid from the tank to the ROW Line of 111th Place. The construction meter was then connected to the 2 inch PVC line by means of garden hoses.

DCI, INC. worked with Desert Properties Limited Partnership for a permanent Easement for the 2-inch pipeline, which was granted to THUC.

Since then the City has been providing Treated CAP Water to the THUC system through the Temporary connection.

WATER INFRASTRUCTURE FINANCING AUTHORITY LOAN

In December of 1999 the Water Infrastructure Finance Authority of Arizona entered into a Loan Agreement with THUC agreeing to provide financing of the Costs to obtain the CAP Water Supply and have it treated and transported to THUC's system. The loan provided for financing up to \$ 285,840 at 6.2%. The actual costs totaled \$412,936.63 with the difference coming from profits.

APPROVAL OF THE WIFA LOAN BY THE CORPORATION COMMISSION

On October 5, 1999 THUC filed with the Arizona Corporation Commission an application for approval to borrow \$285,840 in long-term debt from the Water Infrastructure Finance Authority of Arizona for the purpose of purchasing existing Central Arizona Project ("CAP") allocations, a development fee for treatment of the CAP water, consulting fees, plant additions and delivery charges associated with the CAP water. On the 1st day of February, 2000, Decision NO. 62286, DOCKET NO. W-02483A-99-0558, the application was approved.

CITY OF SCOTTSDALE TREAT AND TRANSPORT AGREEMENT

In January 2000 the Treat and Transport Agreement between THUC and the City of Scottsdale was approved by the City Council.

CAP WATER SUPPLY

On February 22, 2002 the Superior Court of the State of Arizona ratified, confirmed, and validated the Subcontract for Central Arizona Project Water, entered into on July 20, 2002, by and among the United States of America, the Central Arizona Water Conservation District and Tonto Hills Utility Company.

PUMP STATION 94

One of the requirements of the City to deliver the ultimate CAP supply to the THUC system was to increase the capacity of Pump Station 94, owned by the City of Scottsdale. Desert Mountain Development needed to, also, increase its capacity. THUC and Desert Mountain negotiated an agreement to accomplish the rebuild. The construction is complete.

WAIVER OF COS REQUIREMENT FOR AN ORIFICE PLATE

In the agreement with the COS there was a requirement that an orifice plate be installed in the line from the meter to the tank to restrict the flow from the COS system to a maximum of 70 gpm. While using the temporary connection, the operator of the THUC system became concerned that the installation of an orifice plate would not permit the receipt of the full 70 gpm from the COS System. DCI, INC. worked with the operator and became equally concerned. Calculations were prepared by DCI, INC. and shared with the COS. The City of Scottsdale waived the requirement to install an orifice plate based on these calculations and the provision that if delivery of more than 70 gpm became a problem for COS customers, THUC would install an orifice plate.

NEW PERMANENT NON-GROUNDWATER SUPPLY ...CAPITAL COSTS

DCI, INC., in behalf of THUC, negotiated an agreement with the City of Scottsdale to treat and transport Water from the Central Arizona Project Canal (The canal transports water from the Colorado River) through the City's system to THUC's system.

THUC, the City of Scottsdale and the Town of Carefree received the transfer of CAP allocations of water previously held by BHP Copper. THUC's share was 71 acre-feet and cost THUC approximately \$37,112.

Federal Law required an Environmental clearance for the Spotted Owl and Indian Artifacts.

This consultant cost totaled \$28,528.

The Bureau of Reclamation assisted in the processing of the required approvals. Their charges were \$8,300.

The charges paid to the CAWCD for back taxes and other charges were \$27,511.

The agreement with the COS provided that THUC would pay the same Development Fee as other new customers. The development fee provides for the portion of the capital cost required to treat and transport the CAP water to THUC. The cost paid in 2002 for transportation of 30 acre-feet was \$180,641.41. The charge to transport the remaining 41 acre feet of CAP water will be paid at some point in the future when additional capacity is required and at the rates in effect at that time. At the current rate the cost to transport all 71 acre feet would have been \$427,515 to supply 205 lots.

Over time THUC will purchase the balance of the 71 acre-feet from the City of Scottsdale. Scottsdale staff has estimated that this charge will increase approximately 5% per year.

In addition THUC must increase the capacity of a COS pump station that will deliver THUC's water to its system. THUC's share of the cost to increase the pump station's capacity was \$67,250.

The combined total of the cost of the CAP water supply, the Environmental Consultant charges, the COS development fee, and the pump station was \$412,936.63. The majority of which (\$285,840) was borrowed from the Water Infrastructure Finance Authority of Arizona at an annual interest rate of 6.25%, with the difference coming from profits .

NEW PERMANENT NON-GROUNDWATER SUPPLY ...OPERATING COSTS

THUC pays to the CAP a charge of approximately \$107 per acre-foot of CAP water used.

In addition THUC pays to the COS a monthly charge for the quantity of CAP water treated and transported by the COS for THUC. This charge is billed at the same rate used to bill COS customers less the cost for the CAP Water paid to the CAWCD by THUC, plus a surcharge of 10% for service outside the City, together with a surcharge of 20% for lifting water to a greater elevation than the average elevation of the COS system.

SATISFACTION OF ALL CONDITIONS OF THE THUC & CITY OF SCOTTSDALE AGREEMENT

On July 1, 2003, David M. Mansfield, General Manager, Water Resources Department, City of Scottsdale signed a letter addressed to Don Unthank, President, Tonto Hills Utility Company **that "confirmed that Tonto Hills Utility Company has satisfied all conditions precedent to the City's treatment and transport obligations under the Agreement and the City stands ready to fulfill its obligations under the Agreement for the delivery of up to 30 acre-feet per year."**

TONTO HILLS UTILITY COMPANY REQUESTS THAT THE ARIZONA CORPORATION COMMISSION STAFF THAT THE MORATORIUM BE LIFTED

On July 15, 2003, THUC requested that the Arizona Corporation Commission lift the moratorium.

...

ARIZONA CORPORATION COMMISSION TERMINATED THE MORATORIUM ON NEW CONNECTIONS

On July 31, 2003, the Arizona Corporation Commission, by Staff Memorandum to Docket Control (Docket No. W-02483A-97-0306, Decision No. 60266), "Staff has determined that the Company has met the requirements for cessation of the moratorium on new connections, as contemplated in Decision No. 60266, and therefore, the moratorium approved for Tonto Hills in Decision No. 60266 shall no longer be in effect."
TONTO HILLS UTILITY COMPANY ADVISE ITS CUSTOMERS THAT THE MORATORIUM HAS BEEN TERMINATED

On August 8, 2003, Don Unthank, President, advised the Customers of THUC that:

1. The Tonto Hills Utility Company had satisfied the requirements of the Federal and Local Governments regarding the through put of CAP water to the community.
2. The Arizona Corporation Commission had terminated the moratorium on new meter connections per THUC's request.

BENJAMIN FRAKLIN'S PERSPECTIVE

Benjamin Franklin, in his Poor Richard's Almanac, provided us with the following:

*"When the well's dry,
We know the worth of water."*

APPENDIX

A

**Appendix: Water Compliance Affidavits and ADOR Tax Clearance
Form**

SEE APPENDIX B FOR COMPLETED FORMS

ARIZONA CORPORATION COMMISSION STATUS REQUEST

TO:

DATE: _____

Maricopa County Environmental Services Department
Drinking Water Program Manager Attention: John Kolman
1001 N. Central Ave. Suite 150
Phoenix, AZ 85004-1935
Phone 602-506-6666
Fax 602-506-6925

FROM:

Water Company _____
PWS Name: _____
PWS I.D. Number: _____
Mailing Address: _____
City, State, Zip Code _____

Phone Number: _____
FAX: _____

Please return completed request to ACC Utilities Engineering (FAX 602-542-2129) and to the Company at address listed above within 30 days.

Compliance Status Report

Overall Compliance Status: No Major Deficiencies Major Deficiencies
Comments:

Monitoring and Reporting Deficiencies: No Deficiencies Major Deficiencies
List deficiencies:

Operation and Maintenance Deficiencies: No Deficiencies Major Deficiencies
Date of last inspection / sanitary survey: _____

Major Operation and Maintenance Deficiencies cited during inspection

- | | | |
|-------------------------------|---|---|
| <input type="checkbox"/> None | <input type="checkbox"/> unable to maintain 20 psi | <input type="checkbox"/> inadequate storage |
| | <input type="checkbox"/> cross connection/backflow problems | <input type="checkbox"/> surface water treatment rule |
| | <input type="checkbox"/> treatment deficiencies | <input type="checkbox"/> approval of construction |
| | <input type="checkbox"/> certified operator | <input type="checkbox"/> other |

Comments:

Enforcement Action:

Has enforcement action been taken? Yes No
Is water system in compliance with Consent /Compliance Orders/Agreements? Yes No
Comments:

System Information:

Number of Points of Entry ____ Population Served ____ Connections Served ____

Compliance Review Conducted by: _____

Phone: _____ **Date:** _____

Based on data submitted by the water system, Maricopa County Drinking Water Program has determined that this system is currently delivering water that (meets/does not meet) water quality standards required by Arizona Administrative Code, Title 18, Chapter 4. This compliance status report does not guarantee the water quality for this system in the future. This compliance status report does not reflect the status of any other water system owned or operated by this utility company.



Arizona Department of Revenue

Tax Clearance Application

1. Application Information

Applicant _____ Phone Number () _____

Address _____

City _____ State _____ Zip Code _____

2. Tax Clearance Purpose (Check Only One Box)

<input type="checkbox"/> Dissolution of Corporation ** <input type="checkbox"/> Withdrawal from Arizona **	Certificate of Compliance for Dissolution or Withdrawal
<input type="checkbox"/> Sale of Business <input type="checkbox"/> Personal <input type="checkbox"/> Residency <input type="checkbox"/> Other _____	Letter of Good Standing

3. Application Type (Check Only One Box and Provide Tax Identification Number(s))

<input type="checkbox"/> Corporation <input type="checkbox"/> S Corporation <input type="checkbox"/> Partnership <input type="checkbox"/> Tax Exempt Organization <input type="checkbox"/> Limited Liability Company <input type="checkbox"/> Limited Liability Partnership	Federal Employer ID number _____ - _____ OR AZ Transaction Privilege License Number _____ - _____ - _____ OR AZ Withholding Tax License Number _____ - _____ - _____
<input type="checkbox"/> Estate <input type="checkbox"/> Trust <input type="checkbox"/> Individual	Social Security Number _____ - _____ - _____ OR AZ Transaction Privilege License Number _____ - _____ - _____ OR AZ Withholding Tax License Number _____ - _____ - _____

4. Signature

Print Name _____ Print Specific Title (Corporate Officer, Partner, Individual) _____

Signature _____ Date _____

5. Send Tax Clearance Application to:

Arizona Department of Revenue
 TCS 7th Floor
 PO Box 29070
 Phoenix AZ 85038-9070
 Telephone (602) 542-4472

Power of Attorney: If this application is submitted by anyone other than a Corporate Officer, General Partner, or Individual (Sole Proprietor), Arizona Form 285 (General Disclosure/Representation Authorization Form) is required. See <http://www.revenue.state.az.us/2001forms.htm>

Unsigned applications will not be processed and faxed applications will not be processed.

** Not applicable to Estate, Trust, or Individual application types.

APPENDIX

B

**WATER RATE APPLICATION CHECK LIST
ORIGINAL APPLICATION PACKAGE ITEMS**

APPENDIX B

WATER RATE APPLICATION CHECKLIST

Please use the following checklist to ensure that all necessary attachments are included in the application. Provide an explanation for any omitted item. Please include 15 copies of this application in your application submission. Also, please include three packets with copies of checklist items 5-11.

ORIGINAL APPLICATION PACKAGE ITEMS

1. The Arizona Department of Environmental Quality ("ADEQ") or Maricopa County Environmental Services Department ("MCESD") compliance status report. Use the appropriate request form in the appendix at the end of this application to obtain the status report. A separate form should be used for each public water system, as defined by ADEQ, that is part of this application. Submit the completed status report(s) obtained from ADEQ or MCESD with your application.
2. The Arizona Department of Revenue ("ADOR") certificate of compliance letter of good standing. Use the tax clearance application in the appendix at the end of this application in order to obtain the certificate of compliance. (Send in the certificate of compliance with your application.)
3. The utility's most recent ADEQ annual sampling fee invoice for its Monitoring Assistance Program.
4. Invoices for each plant asset purchase in excess of \$150 for the Test Year, as well as all of the intervening years since the utility's prior Test Year as itemized on page **Error! Bookmark not defined.**

Please provide 3 packets with copies of the following information to support entries on the Income Statement on page **Error! Bookmark not defined.**:

5. A breakdown by name, position, salary, and duties for the Salaries and Wages expense. (Acct. 601)
6. Invoices for Purchased Water during the Test Year. (Acct. 610)
7. Invoices for Purchased Power during the Test Year. (Acct. 615)
8. Invoices for Repairs and Maintenance in excess of \$150 incurred during the Test Year. (Acct. 620)
9. Invoices for Outside Services in excess of \$150 incurred during the Test Year. (Acct. 630)
10. Invoices for Water Testing during the Test Year (Acct. 635)
- Statements from the county for Property Tax expenses incurred during the Test Year. (Acct. 408.11)

12..RENTAL EQUIPMENT

13..REPAIRS AND MAINTENANCE

SECTION

1

SECTION 1.0



Maricopa County
Environmental Services

Water and Waste Management
Division
1001 N. Central Avenue #150
Phoenix, Arizona 85004
Phone: (602) 506-6666
Fax: (602) 506-6925
TDD: 602 506 6704

January 23, 2004

Mr. Donald Unthank
Tonto Hills Water System
11802 E. Blue Wash Road
Cave Creek, AZ 85331

Re: PWS # 07-076

Notification of Missed Monitoring – Department Letter dated December 9, 2003

Dear Mr. Unthank:

Based on updated information in the Arizona Department of Environmental Quality monitoring database, the required analysis results for nitrate have been posted for the years 2002 and 2003.

Please be advised the compliance status of the Tonto Hills Water system has been changed to: **Full Compliance**.

Thank you for your attention to the referenced issue. If you have further questions, please contact Michael Mallette at (602) 506-6644 or mmallette@mail.maricopa.gov.

Sincerely,

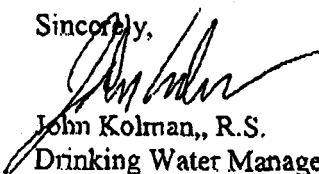
John Kolman, R.S.
Drinking Water Manager

cc: ADEQ
ACC

ARIZONA CORPORATION COMMISSION STATUS REQUEST

TO:

DATE: 10-27-03

Maricopa County Environmental Services Department
Drinking Water Program Manager Attention: John Kolman
1001 N. Central Ave. Suite 150
Phoenix, AZ 85004-1935
Phone 602-506-6666
Fax 602-506-6925

FROM:

Water Company
PWS Name:
PWS I.D. Number:
Mailing Address:
City, State, Zip Code

TONTO HILLS UTILITY COMPANY
TONTO HILLS WATER CO.
0407046
11802 E. BLUE WASH ROAD
CAVE CREEK, AZ 85331

Phone Number:
FAX:

480-948-5030 (OFFICE) 480-488-0253 (HOME)
480-922-9872

Please return completed request to ACC Utilities Engineering (FAX 602-542-2129) and to the Company at address listed above within 30 days.

Compliance Status Report

Overall Compliance Status: [] No Major Deficiencies [] Major Deficiencies

Comments:

Monitoring and Reporting Deficiencies: [] No Deficiencies [] Major Deficiencies

List deficiencies:

Operation and Maintenance Deficiencies: [] No Deficiencies [] Major Deficiencies

Date of last inspection / sanitary survey: _____

Major Operation and Maintenance Deficiencies cited during inspection

- [] None [] unable to maintain 20 psi [] inadequate storage
[] cross connection/backflow problems [] surface water treatment rule
[] treatment deficiencies [] approval of construction
[] certified operator [] other

Comments:

Enforcement Action:

Has enforcement action been taken? [] Yes [] No
Is water system in compliance with Consent /Compliance Orders/Agreements? [] Yes [] No

Comments:

System Information:

Number of Points of Entry ___ Population Served ___ Connections Served ___

Compliance Review Conducted by: _____

Phone: _____ Date: _____

Based on data submitted by the water system, Maricopa County Drinking Water Program has determined that this system is currently delivering water that (meets/does not meet) water quality standards required by Arizona Administrative Code, Title 18, Chapter 4. This compliance status report does not guarantee the water quality for this system in the future. This compliance status report does not reflect the status of any other water system owned or operated by this utility company.

MEMO

DCI, INC.
815 South Rochester
MESA, AZ 85206
480-218-5405
FAX-480-699-1978
E-mail...lduekerdci@cox.net

DATE: February 4, 2004

TO: Rate Application to ACC Status Request from ADEQ
FROM: Leonard L. Dueker, P.E. President



cc:

SUBJECT: Arizona Corporation Commission Status Request
To ADEQ

On 10/27/03 requests for Compliance Status Reports were sent to ADEQ and Maricopa County Environmental Services Department (MCESD). The request to MCESD was sent to the attention of John Kolman.

In a letter dated January 23, 2004 from John Kolman, Tonto Hills Utility Company was advised that the Tonto Hills Water System was in **FULL COMPLIANCE**. Copy of this letter precedes this Memo.

On January 14, 2004 DCI, INC. sent a FAX to Jim Puckett of ADEQ requesting help with getting the ADEQ form completed. A copy of this FAX and attachments follows this Memo.

On February 4, 2004, DCI, INC. received a phone call from Jim Puckett, of ADEQ, in which he informed DCI, INC. that the ADEQ enforcement responsibilities have been delegated to MCESD by ADEQ and therefore John Kolman should be contacted regarding the request.

In as much as MCESD is now responsible for ADEQ, also, both requests must have been answered with the letter of January 23, 2004 signed by John Kolman and which precedes this Memo.

February 4, 2004
DCI, INC.
Tonto Hills.Rate Case & Hook Up Fee ..2003A..ADEQLTR

DCI INC.
815 SOUTH ROCHESTER
MESA, AZ 85206-2749

PHONE: (480) 218-5405 * FAX: (480) 699-1978

TOTAL NUMBER OF PAGES SENT

INCLUDING COVER PAGE:

3

DATE:

1 / 14 / 2004
MONTH DAY YEAR

FAX TO

DIRECTED TO:

JIM PUCKETT

FAX NUMBER:

602-771-4505

FROM

FAX SENT BY:

LEONARD DUEKER

PHONE:

480-218-5405

SPECIAL INSTRUCTIONS OR MESSAGE:

① YOU PREPARED THE ATTACHED DRAWING
WATE COMPLIANCE REPORT FOR
ME -

② WE ARE DOING A RATE CASE APPROXIM
AND THE COMMISSION WANTS THE
ATTACHED REPORT COMPLETED FOR
TANTO HILLS UTILITY COMPANY - IT
LOOKS LIKE THE ONE YOU DID FOR ME FOR
GRANITE JELLS WATER COMPANY -

③ I WOULD APPRECIATE YOUR HELP AGAIN -
IF YOU CAN COMPLETE THE REPORT, PLEASE
SEND A COPY TO ACC & DON WITH THANKS & FAX A COPY TO ME

CONFIDENTIALITY NOTE

The information in this facsimile is intended only for the use of the addressee and may contain information that is personal and confidential. If you are not the intended recipient or the employee or agent responsible for delivering this transmittal to the intended recipient, you are hereby notified that any dissemination, distribution, or copying of this communication is strictly prohibited. If you have received this communication in error, please notify us immediately by telephone and return the original message to us at the address above via the U.S. Postal Service. We will reimburse postage. Thank you.

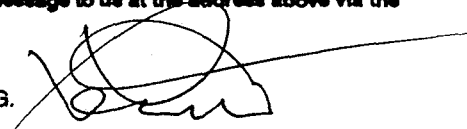
Thanks

PLEASE CALL US IF YOU HAVE ANY PROBLEMS OR IF THERE ARE PAGES MISSING.

Arizona Department of Environmental Quality
Water Quality Compliance Assurance Unit
 1110 W. Washington Street, 5415B-1
 Phoenix, AZ 85007

Drinking Water Compliance Status Report

Public Water System Name: Granite Dells Water Co.

Public Water System ID #: 13-030

Overall Compliance Status: No Major Deficiencies Major Deficiencies

Monitoring and Reporting Status: No Major Deficiencies Major Deficiencies
 Comments:

Operation and Maintenance Status: No Major Deficiencies Major Deficiencies

Major unresolved/ongoing operation and maintenance deficiencies:

- | | |
|---|---|
| <input type="checkbox"/> unable to maintain 20psi | <input type="checkbox"/> inadequate storage |
| <input type="checkbox"/> cross connection/backflow problems | <input type="checkbox"/> surface water treatment rule |
| <input type="checkbox"/> treatment deficiencies | <input type="checkbox"/> approval of construction |
| <input type="checkbox"/> certified operator | <input type="checkbox"/> other |

Date of last inspection / sanitary survey: 10-18-90

Administrative Orders:

Is an ADEQ administrative order in effect? Yes No

Comments:

*Jim you did this for me previously
LEONARD*

System Information:

Number of Points of Entry 1 Number of Sources 1 Population Served 60

Service Connections 30 Initial Monitoring Year 1-1-04 Initial MAP year M/A

Evaluation completed by: Jim Puckett

Phone: 602-771-4649 Date: 10-24-03

Based on data submitted by the water system, ADEQ has determined that this system is currently delivering water that meets water quality standards required by Arizona Administrative Code, Title 18, Chapter 4. This compliance status report does not guarantee the water quality for this system in the future. This compliance status report does not reflect the status of any other water system owned by this utility company.

TO:
Arizona Department of Environmental Quality
Drinking Water Compliance Enforcement Unit
1110 West Washington Avenue, 5th Floor
Phoenix, Arizona 85007
Phone: 602-771-4624
Fax: 602-771-4505

DATE: 10-27-03

FROM:
Water Company:
Mailing Address:
City, State, Zip Code
Phone Number:
FAX:

TONTO HILLS UTILITY COMPANY
11802 E. BLUE WASH ROAD
CAVE CREEK, AZ 85331
480-948-5030 (OFFICE) 480-488-0253 (HOME)
480-922-9872



Please return completed request to ACC Utilities Engineering (FAX 602-542-2129) and to the Company at address listed above within 30 days.

Compliance Status Report

PWS Name: TONTO HILLS WATER CO.
PWS ID #: 0407076

Overall Compliance Status: No Major Deficiencies Major Deficiencies
Comments:

Monitoring and Reporting Deficiencies: No Deficiencies Major Deficiencies
List deficiencies:

Operation and Maintenance Deficiencies: No Deficiencies Major Deficiencies
Date of last inspection / sanitary survey: _____

Major Operation and Maintenance Deficiencies cited during inspection

- | | | |
|-------------------------------|---|---|
| <input type="checkbox"/> None | <input type="checkbox"/> unable to maintain 20 psi | <input type="checkbox"/> inadequate storage |
| | <input type="checkbox"/> cross connection/backflow problems | <input type="checkbox"/> surface water treatment rule |
| | <input type="checkbox"/> treatment deficiencies | <input type="checkbox"/> approval of construction |
| | <input type="checkbox"/> certified operator | <input type="checkbox"/> other |

Comments:

Administrative Orders:

Is ADEQ administrative order in effect? Yes No
Is US EPA administrative order in effect? Yes No
Comments:

System Information:

Number of Points of Entry _____ Population Served _____ Connections Served _____

DWCE Evaluation completed by: _____

Phone: _____ Date: _____

Based on data submitted by the water system, ADEQ has determined that this system is currently delivering water that (meets/does not meet) water quality standards required by Arizona Administrative Code, Title 18, Chapter 4. This compliance status report does not guarantee the water quality for this system in the future. This compliance status report does not reflect the status of any other water system owned by this utility company.

SECTION

2

SECTION 2.0

Certificate of Compliance Letter of Good Standing

Tonto Hills Utility Company

This Certificate of Compliance is issued pursuant to Arizona Revised Statutes Section 42-1110 and Section 43-1151. It certifies that, according to department records, the above named taxpayer has filed and paid all taxes due under Title 42 and Title 43, specifically and only as to the following described types and identification license number:

TAX TYPE

Federal Employer Identification Number

Transaction Privilege Tax License

Withholding License

This certification is made conditionally and is subject to the findings of any subsequent audit.

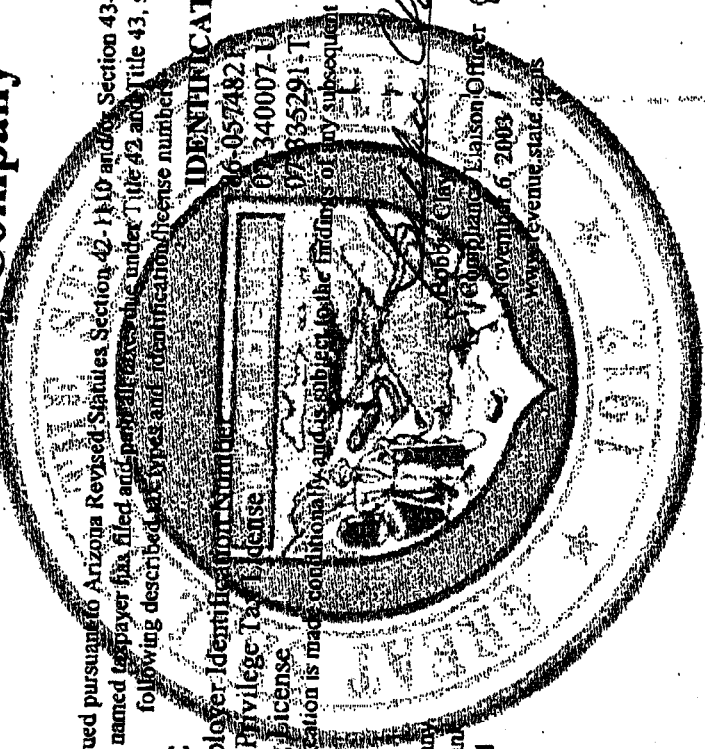

IDENTIFICATION

66-0574821

66-340007-1

66-635291-1

Issued To:

Tonto Hills Utility Company
Attn: Mr. Donald J. Umhan
11802 E. Blue Wash Road
Cave Creek, AZ 85331

602-716-6785

Elialson Officer

November 6, 2003

www.revenue.state.az.gov



Arizona Department of Revenue

Tax Clearance Application

1. Application Information

Applicant TONTO HILLS UTILITY COMPANY Phone Number 480-948-5030 (OFFICE)
480-488-0253 (HOME)
 Address 11802 E. BLUE WASH ROAD
 City CAVE CREEK State AZ Zip Code 85331

2. Tax Clearance Purpose (Check Only One Box)

<input type="checkbox"/> Dissolution of Corporation ** <input type="checkbox"/> Withdrawal from Arizona **	Certificate of Compliance for Dissolution or Withdrawal
<input type="checkbox"/> Sale of Business <input type="checkbox"/> Personal <input type="checkbox"/> Residency <input checked="" type="checkbox"/> Other <u>APPLICATION TO CORPORATION COMMISSION FOR RATE INCREASE</u>	Letter of Good Standing

3. Application Type (Check Only One Box and Provide Tax Identification Number(s))

<input type="checkbox"/> Corporation <input checked="" type="checkbox"/> S Corporation <input type="checkbox"/> Partnership <input type="checkbox"/> Tax Exempt Organization <input type="checkbox"/> Limited Liability Company <input type="checkbox"/> Limited Liability Partnership	Federal Employer ID number _____ - _____ OR AZ Transaction Privilege License Number _____ - _____ - _____ OR AZ Withholding Tax License Number _____ - _____ - _____
<input type="checkbox"/> Estate <input type="checkbox"/> Trust <input type="checkbox"/> Individual	Social Security Number _____ - _____ - _____ OR AZ Transaction Privilege License Number _____ - _____ - _____ OR AZ Withholding Tax License Number _____ - _____ - _____

4. Signature

DAVID J. WITKAMP PRESIDENT & GENERAL MANAGER
 Print Name Print Specific Title (Corporate Officer, Partner, Individual)

10-27-03

Signature

Date

5. Send Tax Clearance Application to:

Arizona Department of Revenue
 TCS 7th Floor
 PO Box 29070
 Phoenix AZ 85038-9070
 Telephone (602) 542-4472

Power of Attorney: If this application is submitted by anyone other than a Corporate Officer, General Partner, or Individual (Sole Proprietor), Arizona Form 285 (General Disclosure/Representation Authorization Form) is required. See <http://www.revenue.state.az.us/2001/forms.htm>

Unsigned applications will not be processed and faxed applications will not be processed.

** Not applicable to Estate, Trust, or Individual application types.

SECTION

3

SECTION 3.0



ARIZONA DEPARTMENT OF ENVIRONMENTAL QUALITY
MONITORING ASSISTANCE PROGRAM
ANNUAL SAMPLING FEE INVOICE

* Pursuant to A.R.S. § 49-113, interest will be charged if full payment is not received by the specified due date. If you dispute the amount listed, please contact ADEQ as soon as possible. To reduce interest costs on an unpaid invoice, you may remit an amount that you believe is not in dispute. However, if nonpayment is due to wilful neglect, you may suffer an additional five percent penalty of up to twenty-five percent of the amount due for each month or fraction of a month the amount is past due.

If you have any questions about your invoice, contact
W. Scott Steinhagen at (602) 771-4445
or toll-free within Arizona at (800) 234-5677, extension 4445

Pursuant to A.R.S. § 49-360 F and A.A.C. R18-4-224 through R18-4-226, "The director shall establish fees for the monitoring assistance program to be collected from all public water systems..."

Account/PWSID #: 7076	Invoice Number 59712
To: TONTO HILLS UTILITY CO 11802 E BLUE WASH RD CAVE CREEK, AZ 85331	Billing for Calendar Year: 2003
 Pd 12-402 CR 2859	Due Date: December 16, 2002
	Total Amount Due \$ 471.49
	Amount Paid \$

↑ Keep the top portion for your records. ↑

ADEQ Federal Tax #866004791

SECTION

4

SECTION 4.0

Company Name:

Tonto Hills Utility Company

Test Year Ended:

December 31, 2002

**INVOICES OF EFFORTS REQUIRED TO OBTAIN
A CAP WATER SUPPLY**

Section Number

4-1	\$3,142.30	BROWN & CALDWELL...SEARCH for WELLS
4-2	\$49,100.00	DCI, INC. INVOICES
4-3	\$38,998.68	HUSTEAD ENGINEERING INVOICES
4-4	\$7,100.00	SOUTHWEST COMMUNITY RESOURCES
4-5	\$2,364.00	J STANLEY EDWARDS ...ATTORNEY
4-6	\$67,250.00	BLUCOR... PS 94 INCREASE CAPACITY
4-7	\$180,641.41	COS - TREAT & TRANSPORT
4-8	\$8,300.00	BOR (Burea of Reclamation)
4-9	\$27,511.00	BHP - CAWCD
4-10	\$28,528.60	SWCA..ENVIRONMENTAL
	\$412,936.00	TOTAL

1

SECTION 4-1

BROWN AND CALDWELL

2

April 26, 1995

Mr. Jim Skane
Tonto Hills Utility Company
42062 N. Turquoise Lane
Cave Creek, Arizona 85331

15-2389/01

Subject: Well Feasibility/Well Siting Investigation
Tonto Hills, Arizona

Dear Mr. Skane:

Brown and Caldwell is pleased to provide Tonto Hills Utility Company with this hydrogeologic study addressing the feasibility and preferable locations for a water supply well.

This investigation was conducted in accordance with our agreement of February 28, 1995. Brown and Caldwell was authorized by Tonto Hills Utility Company to conduct a portion of the tasks listed in the February 28, 1995 Agreement, including: 1) the literature review, 2) fracture trace analysis, and 3) interim report preparation. Accordingly, the investigation presented herein includes only those tasks and does not include aquifer testing of the Tonto Hills wells or design considerations for any proposed wells.

BACKGROUND

Tonto Hills Utility Company currently serves approximately 80 homes and will ultimately serve approximately 200 homes at total buildout. The current water supply is provided by two wells, both of which are located on U.S. Forest Service land adjacent to the Tonto Hills service area. The "upper" well is located in the Northwest $\frac{1}{4}$ of the Northwest $\frac{1}{4}$ of the Northwest $\frac{1}{4}$ of Section 10, in Township 6 North Range 3 East (also designated as A(6-3)10bbb). The upper well has a reported total depth of approximately 400 feet and produces groundwater at a rate of approximately 2 gallons per minute (gpm) during limited pumping periods. The "lower" well is located in the Southeast $\frac{1}{4}$ of the Northeast $\frac{1}{4}$ of the Southeast $\frac{1}{4}$ of Section 10, in Township 6 North Range 3 East (also designated as A(6-3)10dad). The lower well has a reported total depth of approximately 900 feet and produces groundwater at a rate of approximately 17 gpm.

BASIC DATA

The available hydrogeologic literature relating to the Tonto Hills area is very limited. Groundwater elevations for the study area were collected from basic data files of the Arizona Department of Water Resources (ADWR), but that data was insufficient for the preparation of a groundwater elevation map. However, it is likely that the direction of groundwater migration

Environmental Engineering And Consulting - Analytical Services

3636 N CENTRAL AVENUE, SUITE 300, PHOENIX, AZ 85012-1999
(602) 222-4444 FAX (602) 222-4466

Mr. Jim Skane
April 26, 1995
Page 2

in the Tonto Hills area is generally southward, from the upper watershed toward the basin. Tonto Hills Utility Company personnel reported the current static water level of the lower well to be 435 feet below land surface.

The upper Tonto Hills well penetrates fractured argillite rocks, which were described by Reynolds (Arizona Geologic Survey, Map 26, 1988) as Precambrian metavolcanics. The argillite rocks have been locally termed "blue shale." The lower Tonto Hills well penetrates fractured and somewhat decomposed granite.

The lower Tonto Hills well has elevated concentrations of radionuclides, as do many of the wells in the region that penetrate the granite formation. Water from this lower well is treated by the Tonto Hills Utility Company to within Arizona Drinking Water Standards.

FRACTURE TRACE ANALYSIS

The flow of groundwater in both the argillite and the granite aquifers occurs through fractures in the crystalline rocks. The granite aquifer is probably closely associated with the overlying alluvium (unconsolidated sediment) in the basin area, but this potential source of groundwater was not targeted in this investigation, due to the water quality problems inherent with the granite aquifer system.

For a water well that is to be installed in a fractured rock aquifer, the more favorable well location is generally along major fracture systems, or at the intersection of two or more fractures. This allows a greater amount of groundwater to migrate to the pumping well through the network of fractures. To characterize the fracture system in the Tonto Hills area, Brown and Caldwell conducted a fracture trace analysis, utilizing photogeology and field mapping to determine the orientation (strike and dip) and overall character of the fractures.

Aerial photographs of the Tonto Hills area were obtained and evaluated by Brown and Caldwell hydrogeologists to identify the principal geologic lineaments in the study area. Geologic lineaments include such linear features as unusually straight drainages, vegetation alignments, and alignment of discolored or weathered surfaces along rock outcrops. These lineaments typically occur as a result of the underlying geologic structure that controls the weathering and vegetation patterns at the land surface. The principal geologic lineaments in the study area are presented in Figure 1, and have two general orientations. One set of lineaments trends to the northeast, and the other lineament set trends to the northwest. The northwestern set of geologic lineaments includes a very dominant lineament that trends west-northwest from the southern flank of Gold Hill along Blue Wash (Figure 1).

The geologic lineaments were augmented with limited geologic mapping and field measurement of fracture orientations in the area. The field measurement of fracture orientations involves using a Brunton compass (a specially designed compass used for measurement of geologic formations and structures) to determine the strike (horizontal orientation) and dip (vertical orientation) of selected fractures in the study area. The orientations of the fractures are

4

Mr. Jim Skane
April 26, 1995
Page 3

presented in Table 1 and are plotted on a map of the Tonto Hills area (Figure 2), for comparison with the geological lineaments. The field-verified fracture orientations indicated two dominant sets of rock fractures trending approximately North 50° West and North 48° East (Table 1, Figure 2). These orientations are very similar to the orientations of predominant geologic lineaments identified by Brown and Caldwell and substantiates our interpretation of the fracture orientation in the Tonto Hills area.

FINDINGS AND RECOMMENDATIONS

It should be noted that the overall hydrogeologic system in the Tonto Hills area is moderate to poor in terms of groundwater resource potential. The most favorable geologic strata for maximum groundwater production would probably be in the alluvium in the basin south of the Tonto Hills community. However, wells in the basin area and the associated granite aquifer are reported to have elevated concentrations of radioactive isotopes, which would necessitate treatment of the water. Poor quality water has not been reported for the fractured argillite aquifer to the north of Tonto Hills, but the relatively small watershed and the reliance on groundwater flow through the discrete fracture system limits the certainty that this aquifer system will support a water supply well.

Based on our fracture trace analysis of the Tonto Hills area, Brown and Caldwell has identified three locations that appear most favorable for the installation of a water supply well. Each of these locations is at the intersection of two primary fractures. The three proposed well locations have been prioritized from most favorable (indicated as "1" in Figure 1) to least favorable (indicated as "3" in Figure 1). The prioritization is predominantly based on the geologic setting, but also considers the location of the existing water distribution system.

Brown and Caldwell appreciates the opportunity to be of service to Tonto Hills Utility Company. If you have any questions regarding this report, or require additional information, please do not hesitate to call.

Very truly yours,

BROWN AND CALDWELL

Marvin F. Glotfelty, R.G.
Groundwater Resources Manager

MFG:rbb
Attachments (3)

cc: Mr. Brian G. Anderson, Brown and Caldwell
Mr. Edward D. Ricci, Brown and Caldwell

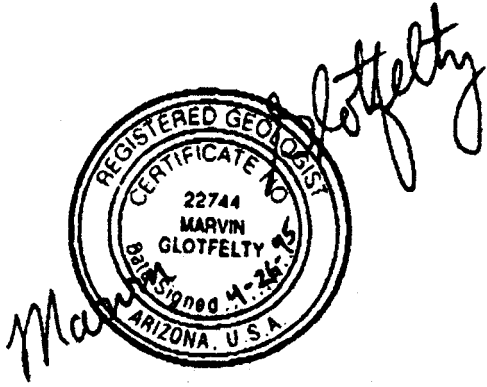

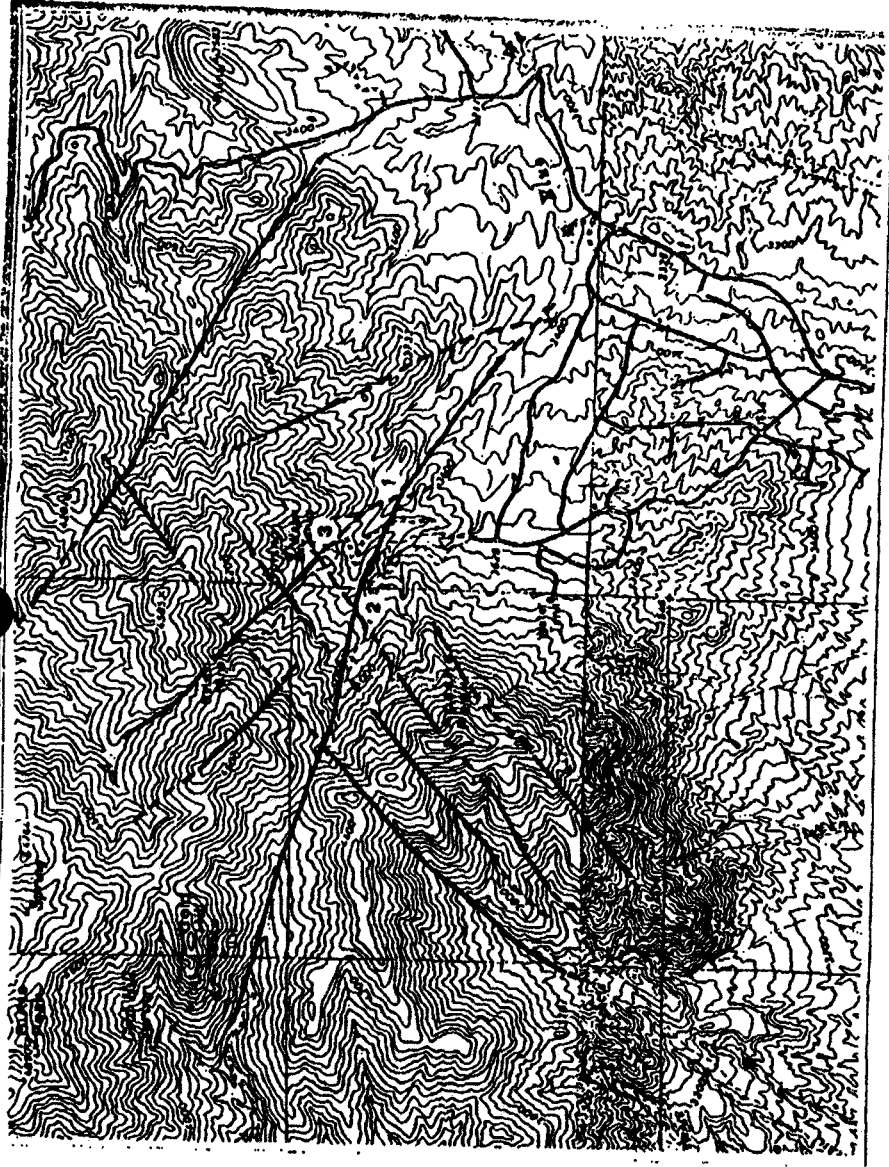

EXPLANATION

— TREND OF GEOLOGIC LINEAMENT
(DASHED WHERE INFERRED)



VICINITY MAP

FIGURE 1
GEOLOGIC LINEAMENTS ORIENTATIONS
TONTO HILLS AREA

SCALE 1:50,000 ARIZONA GEOLOGICAL SURVEY U.S. GEOLOGICAL SURVEY

BROWN AND CALDWELL
3636 NORTH CENTRAL AVENUE - SUITE 300
PHOENIX, ARIZONA (502) 222-4444

72297002 04-08-93 Camp

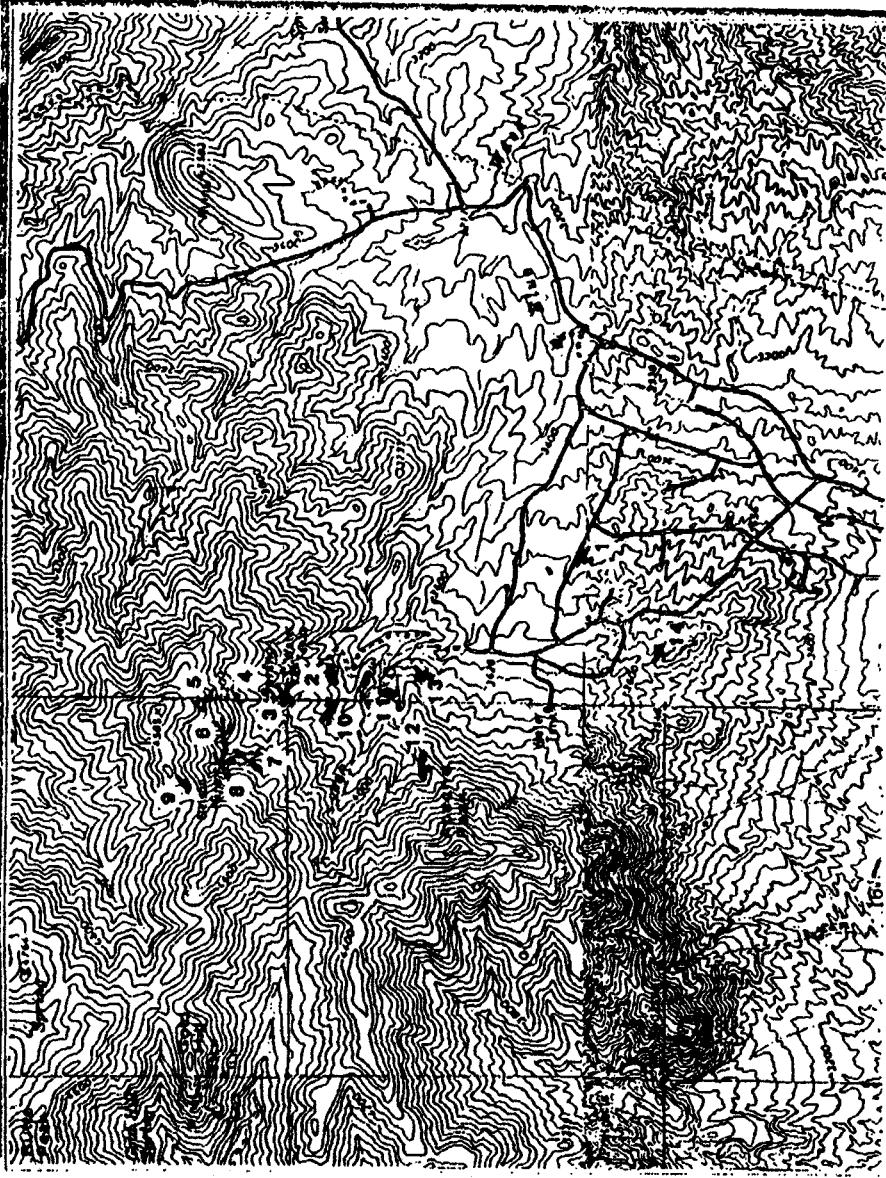

EXPLANATION

STRIKE AND DIP OF FRACTURES
(NUMBER INDICATES STATION I.D.)

NOTE:

SPECIFIC STRIKE AND DIP VALUES PER
STATION I.D. NUMBER AS PRESENTED
TABLE 1.



FIGURE 2
FRACTURE ORIENTATIONS
TONTO HILLS AREA

SOURCE: U.S.G.S. GEOLOGIC MAP 4-34805C1-MN - '53 REV. UNARRANGED.

BROWN AND CALDWELL
3636 NORTH CENTRAL AVENUE - SUITE 300
PHOENIX, ARIZONA (602) 222-4444

7238903 01-08-85 Cont'd

7

Table 1. Orientation of Fractures, Tonto Hills Area, Central Arizona

Station Number	Approximate Location	Fracture Orientation (strike and dip, degrees)	Rock Type
1	A(6-5)10 cda	N55°W, SW 67°	Granite
2	A(6-5)10 bbb	N81°E, NE 67°	Argillite
3	A(6-5)03 ccc	N45°E, SE 84° N39°W, NW 76° N77°W, SE 70°	Argillite
4	A(6-5)03 ccb	N58°E, SE 79°	Argillite
5	A(6-5)04 dda	N15°W, SW 84° N55°W, SW 81°	Argillite
6	A(6-5)04 dda	N89°E, NW 40° N42°W, NE 87° N64°E, NW 80°	Argillite
7	A(6-5)04 ddc	N33°W, NE 85° N19°W, NE 61° N29°E, NW 49°	Argillite
8	A(6-5)04 ddb	N02°W, NE 88° N62°E, SW 63° N57°W, NE 34°	Argillite
9	A(6-5)04 dac	N52°E, SE 76°	Argillite
10	A(6-5)09 aaa	N56°W, SW 81° N83°E, NW 29°	Argillite
11	A(6-5)10 bcb	N03°W, NE 46°	Argillite
12	A(6-5)09 adb	N86°W, SW 70° N43°E, SE 78°	Argillite
13	A(6-5)10 bcb	N30°E, NW 61°	Granite
14	A(6-5)10 ccd	N66°W, SW 85°	Granite

2

SECTION 4-2

**TONTO HILLS UTILITY COMPANY
TEST YEAR 2002**

**DCI, INC. INVOICES
FOR SERVICES REDERED IN OBTAINING
A PERMANENT WATER SUPPLY**

DATE	NUMBER	AMOUNT	
9-7-1996	165	\$500.00	
10-16-1996	172	\$5,000.00	
1-29-1997	182	\$5,000.00	*
3-22-1997	187	\$5,000.00	*
7-10-1997	201	\$5,000.00	*
7-03-1998	246	\$687.50	
8-10-1998	252	\$1,750.00	
9-10-1998	258	\$562.50	
10-16-1998	263	\$1,750.00	
11-3-1998	269	\$937.50	
2-20-1999	281	\$1,562.50	
10-6-1999	314	\$3,850.00	
1-12-2000	325	\$3,312.50	
10-6-2000	354	\$3,062.50	
5-2-2003	408	\$11,125.00	
	TOTAL	\$49,100.00	

\$15,000.00

*** Included in previous rate case, staff provided that they should be included in next rate case when plant was of benefit to customers**

DCI INC.
 815 S ROCHESTER
 MESA, AZ 85206-2749

Invoice

Invoice Number
 409

Voice: 602-835-9584
 Fax: 602-530-3492

Invoice Date
 5/2/2003

TO: TONTO HILLS UTILITY COMPANY
 42602 N. TURQUOISE LANE
 CAVE CREEK, AZ 85331

Page
 1

ATTENTION: Donald Unthank

For Services
 3-2-2003
 Through
 4-30-2003

Customer ID: 1020

SURCHARGE/HOOK UP FEE

Job Description	Customer P.O.	Payment Terms	Due Date
Water Supply Assistance	Agreement 9/04/1996		

Hours	Rate	Description	Amount
57.0	\$125.00	<ul style="list-style-type: none"> ● Developed concept of Surcharge (payment in lump sum or monthly over a 10 year period) for existing customers and a Hook-Up Fee for new customers ● Preparation of spread sheets to review amortization of loan from WIFA. ● Provided for the payment over time as needed of the Developemnt Fee to the COS for additional Treat and Transport Capacity ● Prepared Cash Flow Projections ● Discussed the loan with WIFA representatives ● Prepared a Tariff Sheet following an example provided by Corporation Commission Staff ● Discussed the concept with a member of the Corporation Commission ● Printed out from the Corporation Commission Web Site the information on the requirement to use the Document Control Sheet 	\$7,125.00

Subtotal	7,125.00
Sales Tax	0.00
Total Invoice Amount	7,125.00
Payment Received	0.00
TOTAL	\$7,125.00

Check No.

DCI INC.

815 S ROCHESTER

MESA, AZ 85206-2749

E-mail: lduekerdci@cox.net

Voice: 480-218-5405

Fax: 480-699-1978

TO: TONTO HILLS UTILITY COMPANY
42602 N. TURQUOISE LANE
CAVE CREEK, AZ 85331

ATTENTION: Donald Unthank

Customer ID: 1020

Invoice

Invoice Number

408

Invoice Date

5/2/2003

Page

1

For Services

10-1-2000

Through

2-28-2003

Job Description	Customer P.O.	Payment Terms	Due Date
Water Supply Assistance	Agreement 9/04/1996		

Hours	Rate	Description	Amount
89.0	\$125.00	<ul style="list-style-type: none"> ● Prepared CAP Order for 2002 after preparing projections of use ● Faxed 2002 order plus 15 year projection ● Discussed tank level control with Lou Frederick ● Review Desert Mountain PS 94 Expansion ● Discusse pressure drop issue with Greg Crossman, COS ● Attended meeting with COS, Don Unthank and Desert Mountain on PS 94 who is to pay for or what percenbtage by each ● Discussions with the CAWCD and preparation of procededure and memo regarding the ordering of CAP Water ● Prepared completion Check List for items to be completed per the Agreement with the COS ● Faxed the Check List to Greg Crossman, COS for his concurrence ● Prepared pressure drop calculations and discussed with Greg Crossman, prepared memo to Greg Crossman requesting relief from the requirement to install an orifice plate to control the rate of flow to Tonto Hills Utility Company, and received concurrence ● Prepared DRAFT Agreement between Desert Mountain and Tonto Hills Utility Company for the sharing of costs for the expansion of PS 94 	\$11,125.00

Subtotal	11,125.00
Sales Tax	0.00
Total Invoice Amount	11,125.00
Payment Received	0.00
TOTAL	\$11,125.00

Check No.

1,000.00 # 3013
0.00 # 3031

DCI INC.

**815 S ROCHESTER
MESA, AZ 85206-2749**

Voice: 602-835-9584
Fax: 602-530-3492

TO: TONTO HILLS UTILITY COMPANY
42602 N. TURQUOISE LANE
CAVE CREEK, AZ 85331

ATTENTION: Donald Unthank

Customer ID:

Invoice

Invoice Number

Invoice Date

Page

For Services

Job Description	Customer P.O.	Payment Terms	Due Date
Water Supply Assistance	Agreement 9/04/1996		

Hours	Rate	Description	Amount
24.5	\$125.00	<ul style="list-style-type: none"> ● Assist in the finaling of the Treat & Transport Agreement between the City of Scottsdale and THUC ● Preparation of easment form and meeting with Desert Mountain Properties for the pipeline connecting the City of Scottsdale system to the THUC tank ● Discussions with the CAWCD and preparation of proceedure and memo regarding the ordering of CAP Water ● ● 	\$3,062.50

Subtotal 3,062.50

Sales Tax 0.00

Total Invoice Amount 3,062.50

Payment Received 0.00

TOTAL \$3,062.50

Check No.

*PD CK # 2387
10/13/00*

DCI INC.
1702 EAST HUBER
MESA, AZ 85203-3932

Voice: 480-835-9584
 Fax: 602-530-3492

TO: TONTO HILLS UTILITY COMPANY
 42602 N. TURQUOISE LANE
 CAVE CREEK, AZ 85331

ATTENTION: Donald Unthank

Customer ID:

Invoice

Invoice Number

Invoice Date

Page

For Services
 October 1
 through
 December 31, 99

Job Description	Customer P.O.	Payment Terms	Due Date
Water Supply Assistance	Agreement 9/04/1996		

Hours	Rate	Description	Amount
26.5	\$125.00	<ul style="list-style-type: none"> ● Meeting with Don, Jim and reporter on COS interim water supply ● Meetings with Greg Crossman on revisions to agreement ● Prepare water costs calculations and memo to Don Untank ● Revise Exhibits B & C for agreement ● Phone calls with Don Unthank, Dennis Husted, & Greg Crossman ● Phone conversations with Desert Mountain regarding a license to install a temporary pipeline ● Phone conversations with Desert mountain & Tim Bray regarding permanent easement for pipeline and deeding of lot to Tonto Hills so that a "no build" letter can be provided by Tonto Hills Utility for Environmental Assessment 	\$3,312.50

Subtotal	3,312.50
Sales Tax	0.00
Total Invoice Amount	3,312.50
Payment Received	0.00
TOTAL	\$3,312.50

Check No.

*ck 2240
1-26-00*

FAXED
TO BOB J
10-18-99

DCI INC.
1702 EAST HUBER
MESA, AZ 85203-3932

Voice: 602-835-9584
Fax: 602-530-3492

TO: TONTO HILLS UTILITY COMPANY
 42602 N. TURQUOISE LANE
 CAVE CREEK, AZ 85331

ATTENTION: Donald Unthank

Customer ID: 1020

Invoice

Invoice Number
 314

Invoice Date
 10/6/1999

Page
 1

For Services In
 August, 1998

Job Description	Customer P.O.	Payment Terms	Due Date
Water Supply Assistance	Agreement 9/04/1996		

Hours	Rate	Description	Amount
26.0	\$125.00	<ul style="list-style-type: none"> ● Phone conversations with Lou Frederick and the problems keeping the tank full and the quantity of water that was having to be hauled ● Meeting with City of Scottsdale staff to obtain permission for the installation of a construction meter connection to provide a temporary water supply to eliminate need to haul water ● Make application to City of Scottsdale and coordinate the installation of the construction meter ● Make the \$600.00 deposit required for the construction meter ● Meetings and phone conversations with Desert Mountain for permission to install a temporary connection from the construction meter to the tank 	\$3,250.00
			600.00

PK# 2180
 10-19-99

Subtotal	3,850.00
Sales Tax	0.00
Total Invoice Amount	3,850.00
Payment Received	0.00
TOTAL	\$3,850.00

Check No.

DCI INC.

**1702 EAST HUBER
MESA, AZ 85203-3932**

Voice: 602-835-9584
Fax: 602-530-3492

TO: TONTO HILLS UTILITY COMPANY
42602 N. TURQUOISE LANE
CAVE CREEK, AZ 85331

ATTENTION: Donald Unthank

Customer ID:

Invoice

Invoice Number

Invoice Date

Page

For Services In

and

Job Description	Customer P.O.	Payment Terms	Due Date
Water Supply Assistance	Agreement 9/04/1996		

Hours	Rate	Description	Amount
12.5	\$125.00	<ul style="list-style-type: none">● Prepare briefing document for meeting with Corporation Commission staff● Attend meeting with Corporation Commission Staff, President and Vice President of Company regarding City of Scottsdale Treat and Transport Agreement and BHP water supply●●●	\$1,562.50

Subtotal	1,562.50
Sales Tax	0.00
Total Invoice Amount	1,562.50
Payment Received	0.00
TOTAL	\$1,562.50

Check No.

PD 3/3/99

DCI INC.
1702 EAST HUBER
MESA, AZ 85203-3932

Voice: 602-835-9584
Fax: 602-530-3492

TO: TONTO HILLS UTILITY COMPANY
 42602 N. TURQUOISE LANE
 CAVE CREEK, AZ 85331

ATTENTION: James F. Skane

Customer ID: 1020

Invoice

Invoice Number
 269

Invoice Date
 11/3/1998

Page
 1

For Services In
 October, 1998

Job Description	Customer P.O.	Payment Terms	Due Date
Water Supply Assistance	Agreement 9/04/1996		

Hours	Rate	Description	Amount
7.5	\$125.00	<ul style="list-style-type: none"> ● Prepare memo to Dennis Husted on water tie-in to Scottsdale Send memo to Dennis, Jim Skane & Don Unthank ● Phone conversations with Dennis Husted, Jim Skane and Don Unthank ● Prpare and Fax Opinion of Projected Demands to Dennis Huatead ● ● ● <p style="margin-left: 40px;"><i>11/4 OK Jim Skane Outside Services</i></p>	\$937.50

Subtotal	937.50
Sales Tax	0.00
Total Invoice Amount	937.50
Payment Received	0.00
TOTAL	\$937.50

Check No.

*PO # 1958
11/1/98*

DCI INC.

**1702 EAST HUBER
MESA, AZ 85203-3932**

Voice: 602-835-9584
Fax: 602-530-3492

TO: TONTO HILLS UTILITY COMPANY
42602 N. TURQUOISE LANE
CAVE CREEK, AZ 85331

ATTENTION: James F. Skane

Customer ID: 1020

Invoice

Invoice Number
263

Invoice Date
10/16/1998

Page
1

For Services In
September, 1998

Job Description	Customer P.O.	Payment Terms	Due Date
Water Supply Assistance	Agreement 9/04/1996		

Hours	Rate	Description	Amount
14.0	\$125.00	<ul style="list-style-type: none"> ● Phone conversations with James Skane regarding the Draft Agreement with Scottsdale ● Reviewed Draft Agreement with Scottsdale ● Revise Draft Agreement per above conversations ● Meet with Greg Crossman of Scottsdale regarding Draft Agreement ● Phone conversation with James Skane on update of status ● Reviewed projected demands ● Revised Draft Agreement per the above conversations <p style="text-align: center;"><i>10/22/98 OK to pay. Charge what side serve. J Skane</i></p>	\$1,750.00

Check No. 1940

*Chk #
1940
10/28/98*

Subtotal	1,750.00
Sales Tax	0.00
Total Invoice Amount	1,750.00
Payment Received	0.00
TOTAL	\$1,750.00

DCI INC.

**1702 EAST HUBER
MESA, AZ 85203-3932**

Voice: 602-835-9584
Fax: 602-530-3492

TO: TONTO HILLS UTILITY COMPANY
42602 N. TURQUOISE LANE
CAVE CREEK, AZ 85331

ATTENTION: James F. Skane

Customer ID: 1020

Invoice

Invoice Number
258

Invoice Date
09/10/1998

Page
1

For Services In
August, 98

Job Description	Customer P.O.	Payment Terms	Due Date
Water Supply Assistance	Agreement 9/04/1996		

Hours	Rate	Description	Amount
4.5	\$125.00	<ul style="list-style-type: none"> ● Revise Draft Agreement between Tonto Hills and City of Scottsdale...adding CAGR option ● Meeting with COS staff on agreement <p><i>9/10/98</i> <i>515 for payment</i> <i>change contract</i> <i>received -</i> <i>JF Skane</i></p> <p><i>DO CASH 1928</i></p>	\$562.50

Check No.

Subtotal	562.50
Sales Tax	0.00
Total Invoice Amount	562.50
Payment Received	0.00
TOTAL	\$562.50

DCI INC.
1702 EAST HUBER
MESA, AZ 85203-3932

Voice: 602-835-9584
 Fax: 602-530-3492

TO: TONTO HILLS UTILITY COMPANY
 42602 N. TURQUOISE LANE
 CAVE CREEK, AZ 85331

ATTENTION: James F. Skane

Invoice

Invoice Number
 252

Invoice Date
 08/10/1998

Page
 1

For Services In
 July, 98

Customer ID: 1020

Job Description	Customer P.O.	Payment Terms	Due Date
Water Supply Assistance	Agreement 9/04/1996		

Hours	Rate	Description	Amount
14.0	\$125.00	<ul style="list-style-type: none"> ● Prepare Draft Agreement between Tonto Hills and City of Scottsdale ● Miscellaneous phone calls COS staff <p><i>9/29/98</i> <i>OK for pay ment.</i> <i>Charge legal expenses</i> <i>J. Skane</i></p> <p><i>ck#1912</i></p>	\$1,750.00

Subtotal	1,750.00
Sales Tax	0.00
Total Invoice Amount	1,750.00
Payment Received	0.00
TOTAL	\$1,750.00

Check No.

DCI INC.
1702 EAST HUBER
MESA, AZ 85203-3932

Voice: 602-835-9584
 Fax: 602-530-3492

TO: TONTO HILLS UTILITY COMPANY
 42602 N. TURQUOISE LANE
 CAVE CREEK, AZ 85331

ATTENTION: James F. Skane

Customer ID:

Invoice

Invoice Number

Invoice Date

Page

For Services In

Job Description	Customer P.O.	Payment Terms	Due Date
Water Supply Assistance	Agreement 9/04/1996		

Hours	Rate	Description	Amount
5.5	\$125.00	Review and pepare application to WIFA for financing Deliver exhibits for WIFA application Phone conversation with Dorothy Haines of Corporation Commission regarding invoices <i>PD CLK# 1898</i>	\$687.50

Check No.

Subtotal	687.50
Sales Tax	0.00
Total Invoice Amount	687.50
Payment Received	0.00
TOTAL	\$687.50

DCI INC.
1702 EAST HUBER
MESA, AZ 85203-3932

Invoice

Invoice Number
 165

Invoice Date
 9/07/1996

Page
 1

For Services In
 September

Voice: 602-835-9584
 Fax: 602-530-3492

TO: TONTO HILLS UTILITY COMPANY
 42602 N. TURQUOISE LANE
 CAVE CREEK, AZ 85331

ATTENTION: DON UNTHANK

Customer ID: 1020

Job Description	Customer P.O.	Payment Terms	Due Date
Water Supply Assistance	Agreement 9/04/1996		

Hours	Rate	Description	Amount
4.0	\$125.00	Advance for Consulting Services	\$500.00

Subtotal	500.00
Sales Tax	0.00
Total Invoice Amount	500.00
Payment Received	0.00
TOTAL	\$500.00

Check No. 1334

PAID 9/4/96

DCI INC.

**1702 EAST HUBER
MESA, AZ 85203-3932**

Voice: 602-835-9584
Fax: 602-530-3492

TO: TONTO HILLS UTILITY COMPANY
42602 N. TURQUOISE LANE
CAVE CREEK, AZ 85331

ATTENTION: DON UNTHANK

Customer ID: 1020

Invoice

Invoice Number
172

Invoice Date
10/16/1996

Page
1

For Services In
October & Nov

Job Description	Customer P.O.	Payment Terms	Due Date
Water Supply Assistance	Agreement 9/04/1996		

Hours	Rate	Description	Amount
40.0	\$125.00	Advance for Consulting Services	\$5,000.00

Check No. 1369

Subtotal	5,000.00
Sales Tax	0.00
Total Invoice Amount	5,000.00
Payment Received	0.00
TOTAL	\$5,000.00

*CHK 10/18
DEPOSIT 10/29*

101000 • NOV 1997

QCI INC.
1702 EAST HUBER
MESA, AZ 85203-3932

Voice: 602-835-9584
Fax: 602-530-3492

TO: TONTO HILLS UTILITY COMPANY
42602 N. TURQUOISE LANE
CAVE CREEK, AZ 85331

ATTENTION: James F. Skane

Customer ID:

Invoice

Invoice Number

Invoice Date

Page

For Services in

Job Description	Customer P.O.	Payment Terms	Due Date
Water Supply Assistance	Agreement 9/04/1996		

Hours	Rate	Description	Amount
40.0	\$125.00	Advance for Consulting Services	\$5,000.00
<i>PD CK# 1603 7-15-97</i>			
			Subtotal 5,000.00
			Sales Tax 0.00
			Total Invoice Amount 5,000.00
			Payment Received 0.00
			TOTAL \$5,000.00

Check No.

51427
0000000000

DCI-INC.
1702 EAST HUBER
MESA, AZ 85203-3932

Voice: 602-835-8584
Fax: 602-530-3492

TO: TONTO HILLS UTILITY COMPANY
42602 N. TURQUOISE LANE
CAVE CREEK, AZ 85331

ATTENTION: James F. Skarke

Customer ID: 1020

on hold please

Invoice

Invoice Number

187

Invoice Date

3/22/1997

Page

1

For Services In

March

Job Description	Customer P.O.	Payment Terms	Due Date
Water Supply Assistance	Agreement 9/04/1996		

Hours	Rate	Description	Amount
40.0	\$125.00	Advance for Consulting Services	\$5,000.00

*3/27/97
OK
J. Skarke*

Check No.

Subtotal	5,000.00
Sales Tax	0.00
Total Invoice Amount	5,000.00
Payment Received	0.00
TOTAL	\$5,000.00

NON-CONFIDENTIAL

DCI INC.
1702 EAST HUBER
MESA, AZ 85203-3932

Voice: 602-835-8584
Fax: 602-530-3492

TO: TONTO HILLS UTILITY COMPANY
42602 N. TURQUOISE LANE
CAVE CREEK, AZ 85331

ATTENTION: James F. Skane

Customer ID: 1020

Invoice

Invoice Number
182

Invoice Date
1/29/1997

Page
1

For Services In
January & Febr

Job Description	Customer P.O.	Payment Terms	Due Date
Water Supply Assistance	Agreement 9/04/1996		

Hours	Rate	Description	Amount
40.0	\$125.00	Advance for Consulting Services	\$5,000.00
			Subtotal 5,000.00
			Sales Tax 0.00
			Total Invoice Amount 5,000.00
			Payment Received 0.00
			TOTAL \$5,000.00

1/31/96
J.F. Skane

Check No.

3

SECTION 4-3

**TONTO HILLS UTILITY COMPANY
TEST YEAR 2002**

**HUSTEAD ENGINEERING INVOICES
FOR SERVICES REDERED IN OBTAINING
A PERMANENT WATER SUPPLY**

DATE	AMOUNT	
8-13-1996	\$2,160.00	
1-2-1997	\$2,340.00	*
3-11-1997	\$2,081.68	*
4-8-1997	\$8,895.00	*
4-17-1997	\$3,670.00	*
4-7-1999	\$2,520.00	
4-28-1999	\$280.00	
1-28-2000	\$4,860.00	
3-6-2000	\$1,320.00	
7-19-2000	\$380.00	
3-26-2001	\$2,560.00	
6-5-2001	\$2,232.00	
10-19-2001	\$1,900.00	
1-16-2002	\$400.00	
5-7-2002	\$2,100.00	
7-8-2002	\$1,300.00	
	\$38,998.68	

\$16,986.68
TOTAL

*** Included in previous rate case, staff provided that they should be included in next rate case when plant was of benefit to customers**

Hustead Engineering

568 W. Moon Valley Drive
Phoenix, Arizona 85023

(602) 993-9924

INVOICE

Tonto Hills Water Company
11802 E. Blue Wash Road
Cave Creek, AZ. 85331

July 8, 2002

Attn: Don Unthank

Engineering services to July 8, 2002 for Review of final AN West plans and bid solicitation for pump station modifications at Pump Station # 94, at Desert Mountain.

1. Meeting with AN West and Tonto Hills	2 hr
2. Plan Review w/ Contractors	
Gilbert Pump	4 hr
Flowtech Pump	4 hr
3. Review of Bids/ Modify Cost Allocation	3 hr

TOTAL HOURS	13 hr

Fee Calculation

Engineer 13 hr X \$ 100/hr = \$ 1,300

Amount Due This Invoice \$ 1,300

Handwritten: [Signature] 2783

Handwritten Signature: Dennis Hustead

Dennis Hustead, P.E.
Hustead Engineering

Hustead Engineering

568 W. Moon Valley Drive
Phoenix, Arizona 85023

(602) 993-9924

INVOICE

Tonto Hills Water Company
11802 E. Blue Wash Road
Cave Creek, AZ. 85331

May 7, 2002

Engineering services to 5/7/02 for review of AN West Pump Station modification plans and cost estimate for negotiation of cost sharing purposes between Tonto Hills W.C and Desert Mountain.

1. Review of AN West plans (Preliminary)	4 hr
2. Review of AN West plans (Final)	2 hr
3. Review/Analyze AN West cost estimate and allocation	4 hr
4. Prepare Tonto Hills cost estimate and allocation	8 hr
5. Prepare report for Tonto Hills	3 hr

TOTAL	21 hr

FEE

Engineer 21 hr X \$ 100/hr = \$ 2,100

*pd #2745
5/15/02*



Dennis Hustead, P.E.
Hustead Engineering

Hustead Engineering

568 W. Moon Valley Drive
Phoenix, Arizona 85023

(602) 993-9924

INVOICE

Tonto Hills Water Company
11802 E. Blue Wash Road
Cave Creek, AZ. 85331

January 16, 2002

Engineering services 1/14/02 to 1/16/02 for review of data and preparation of certification for blending plan for MCESD.

1. Review of Data	2 hr
2. Edit of Plan Report	1 hr
3. Filing of Certification	1 hr

TOTAL	4 hr

FEE

Engineer 4 hr X \$ 100/hr = \$ 400

VAD
2672
1-22-02

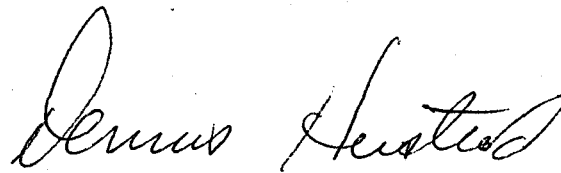

Dennis Hustead, P.E.
Hustead Engineering

Hustead Engineering

568 W. Moon Valley Drive
Phoenix, Arizona 85023

(602) 993-9924

INVOICE

Tonto Hills Water Company
11802 E. Blue Wash Road
Cave Creek, AZ. 85331

October 19, 2001

Engineering services from June 6, 2001 to October 19, 2001 for research and negotiations of PS # 94 capacity for Tonto Hills.

1. Meetings with City of Scottsdale on PS #94 modifications	2 hr
2. Verify pump station requirements per Dueker letter 8/22/01	6 hr
3. Meeting with City of Scottsdale (Grossman)	4 hr
4. Research with AN West	2 hr
5. Field research with AN West and COS	4 hr
6. Reports to Dueker and Unthank	1 hr

Total Hours	19 hr

FEE CALCULATION

Engineer 19 hr X \$100/hr = \$ 1,900

*pd # 26 21
10/25/01*

Dennis Hustead
Dennis Hustead, P.E.
Hustead Engineering

Hustead Engineering

568 W. Moon Valley Drive
Phoenix, Arizona 85023

(602) 993-9924

INVOICE

Tonto Hills Water Company
11802 E. Blue Wash Road
Cave Creek, AZ. 85331

June 5, 2001

Engineering services to June 5, 2001, for the research and preparation of AS-BUILT plans for treatment plant at Tonto Hills.

1. Review files @ MCESD/ Copy Reports & Plans 5/15	3 hr
2. Meeting w/ Don Unthank and Bob Hanus @ Site 5/21	4 hr
3. Review & analyze reports/plans	6 hr
4. Field verification w/ Lou Fredricks	4 hr
5. Prepare As-Built plans	3 hr
6. Prepare Certificate of Completion/ Coordinate w/ Hanus	2 hr

Totals	22 hr

FEE CALCULATION

Engineer	22 hr X \$100/hr = \$ 2,200
Reproduction	= \$ 32

Total Amount Due	\$ 2,232

PL
CR# 2570
6-11-01

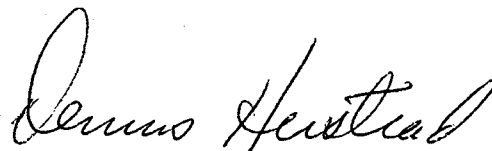

Dennis Hustead, P.E.
Hustead Engineering

Hustead Engineering

568 W. Moon Valley Drive
Phoenix, Arizona 85023

(602) 993-9924

INVOICE

Tonto Hills Water Company
11802 E. Blue Wash Road
Cave Creek, AZ. 85331

March 26, 2001

Attn: Don Unthank

Engineering Services during construction in bidding and evaluating bids for modifications to PS # 94. Services include preparation and delivery of construction plans to prospective bidders, response to contractor's questions, and discussions with Alpha Southwest (successful bidder). Services are for the period 12/20/00 to 3/1/01.

Task Description	Engr	Tech
1. Assist in plan distribution and contractor questions	16	4
2. Preconstruction meeting w/ contractor	4	4
	-----	-----
Total hours to 3/3/01	20	8

FEE CALCULATION

Engineer 20 hr X \$ 100/hr = \$ 2,000

Technician 8 hr X \$ 70/hr = \$ 560

Total Amount Due

\$ 2,560

CK# 2795

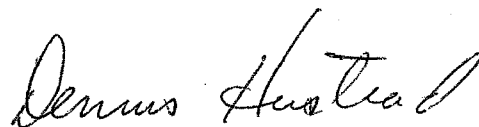

Dennis Hustead, P.E.
Hustead Engineering

Hustead Engineering

568 W. Moon Valley Drive
Phoenix, Arizona 85023

(602) 993-9924

INVOICE

Tonto Hills Water Company
C/O Don Unthank
11802 E. Blue Wash Road
Cave Creek, AZ 85331

July 19, 2000

Engineering services through 7/18/2000, for the revisions to Tonto Hills W.C. plans for the COS pump station and transmission line to the Tonto Hill reservoir. The revisions were necessitated by the relocation of the easement and pipe location by Desert Mountain. The plans have been approved by the City of Scottsdale, and are ready for construction. Reproducible prints are delivered with this invoice.

Revisions to easement and pipe alignment	3 hr
Processing with the City	1 hr
Total Hours	<u>4 hr</u>

FEE DUE 4 hr X \$ 95/hr = \$ 380

*PD CHECK
ON 8-11-00
T.H.W.C. CHECK*

Dennis Hustead
Dennis Hustead, P.E.
Hustead Engineering

Hustead Engineering

68 W. Moon Valley Drive
Phoenix, Arizona 85023

(602) 993-9924

INVOICE

Tonto Hills Water Company
c/o Don Unthank
11802 E. Blue Wash Road
Cave Creek, Az. 85331

March 6, 2000

Engineering services through 3/6/2000, for the processing of construction plans for the Tonto Hills W.C. tie-in to the City of Scottsdale water system at Desert Mountain.

Engineering for processing w/ COS & MCESD	3 hr X \$ 95/hr = \$ 300
Plan Review Fee COS	= \$ 920
Plan Review Fee MCESD	= \$ 100

Total Due This Invoice \$1,320

COPY
L.D.
ACCNTG
DON

Thank You.

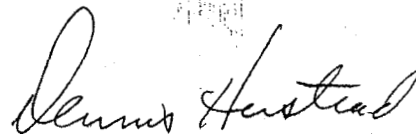

Dennis Hustead, P.E.
Hustead Engineering

2265

TONTO HILLS UTILITY COMPANY
37611 N. CAVE CREEK RD., STE. A
CAVE CREEK, AZ 85331

91-534/1221

DATE 3-7-00

PAY TO THE ORDER OF

HUSTEAD ENGINEERING \$ 1,320.00

THIRTEEN HUNDRED TWENTY DOLLARS DOLLARS Security Features Included Details on back



FOUNDERS BANK of ARIZONA
23305 N. Pima Road, Scottsdale, AZ 85255

TWO SIGNATURES REQUIRED FOR \$500.00 OR MORE

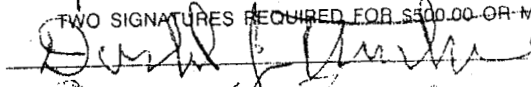
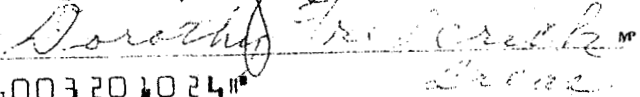
FOR

PLAN REVIEW

⑈002265⑈ ⑆122105346⑆

⑈6003201024⑈

Hustead Engineering

568 W. Moon Valley Drive
Phoenix, Arizona 85023

(602) 993-9924

INVOICE

Tonto Hills Water Company
c/o Don Unthank
11802 E. Blue Wash Road
Cave Creek, AZ. 85331

January 28, 2000

The plans for the Tonto Hills Water Company tie-in to the City of Scottsdale system have been revised to reflect the new pipe alignment, the specification of new pumps to replace the original designed pumps that are no longer available, and the design of a flow control orifice plate (per City requirements) to restrict the flow to Tonto Hills to 70 GPM. Desert Mountain also requested that the noise level of the proposed pumps be compared to the existing pumps, and a report prepared.

The work effort for the additional work is as follows:

	Task Description	Engr	Tech
1	Noise Level Analysis		
	- Mtgs w/ Grunfos Pump Reps	2	
	- Research w/ Grunfos Factory	1	
	- Report Preparation	1	
2	Revisions to Pump Plans		
	- Research w/ Grunfos Reps	2	
	- Pump Selection/Design	4	
	- Plan Revision	4	6
3	Revision to Pipeline Plans		
	- Prepare new plans, process	6	8
4	Orifice Plate Design (Flow Control)		
	- Design	6	
	- Details and Construction Notes	4	8
	- Mtgs, process w/ COS	4	
	TOTALS	34	22

FEE CALCULATION

Engineer 34 hr X \$ 95/hr = \$ 3,230
Technician 22 hr X \$ 65/hr = \$ 1,430
Repro/Plots = \$ 200

Amount Due \$ 4,860

2 set of plans are enclosed for your use. 2 sets are being delivered to Gary Covert at the City of Scottsdale.

2/4/00
PD CKH
2/6/00

Dennis Hustead
Dennis Hustead, P.E.
Hustead Engineering

Hustead Engineering

568 W. Moon Valley Drive
Phoenix, Arizona 85023

(602) 993-9924

INVOICE

Tonto Hills Water Company
c/o Don Unthank
11802 E. Blue Wash Road
Cave Creek, AZ. 85331

April 28, 1999

Engineering services to 4/28/99 for revision to the report and plans of the pump replacement and tie-in of the Scottsdale water system for delivery of the Tonto Hills CAP water supply.

Agreed Lump Sum Fee	\$2,800
Work Completed	100 %

Fee Earned	\$2,800
Previous Payments	-\$2,520

Amount Due	\$ 280

YD # 2092
CR# 5-18-99

Dennis Hustead

Dennis Hustead, P.E.
Hustead Engineering

Hustead Engineering

568 W. Moon Valley Drive
Phoenix, Arizona 85023

(602) 993-9924

INVOICE

Tonto Hills Water Company
c/o Don Unthank
11802 E. Blue Wash Road
Cave Creek, Az. 85331

April 7, 1999

Engineering services to 4/7/99 for the analysis of the pump replacement and tie-in of the Scottsdale water system for delivery of the Tonto Hills CAP water supply.

Agreed Lump Sum Fee	\$2,800
Work Completed	90%

Fee Earned	\$2,520
Previous Invoices	0

Amount Due	\$2,520

*Pub 2067
4-13-99*

Dennis Hustead

Dennis Hustead, P.E.
Hustead Engineering

Hustead Engineering

568 W. Moon Valley Drive
Phoenix, Arizona 85023

(602) 993-9924

Tonto Hills Water Company
c/o Don Unthank
11802 E. Blue Wash Road
Cave Creek, Az. 85331

April 7, 1999

INVOICE

Engineering services to 4/7/99 for the analysis of the pump replacement and tie-in of the Scottsdale water system for delivery of the Tonto Hills CAP water supply.

Agreed Lump Sum Fee	\$2,800
Work Completed	90%
Fee Earned	\$2,520
Previous Invoices	0
Amount Due	\$2,520

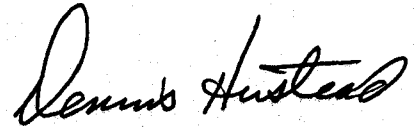

Dennis Hustead, P.E.
Hustead Engineering

2067

TONTO HILLS UTILITY COMPANY
37611 N. CAVE CREEK RD., STE. A
CAVE CREEK, AZ 85331

91-534/1221

DATE 4/13/99

PAY
TO THE
ORDER OF

HUSTEAD ENGINEERING

\$ 2,520.00

Two Thousand Five Hundred Twenty 20/100

DOLLARS 



FOUNDERS BANK of ARIZONA
23305 N. Pima Road, Scottsdale, AZ 85255

TWO SIGNATURES REQUIRED FOR \$500.00 OR MORE

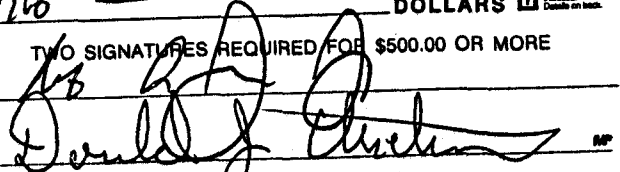

FOR

⑈002067⑈ ⑆122105346⑆

⑈6003201024⑈

Hustead Engineering

568 W. Moon Valley Drive
Phoenix, Arizona 85023

(602) 993-9924 Business
(602) 942-2762 Residence

INVOICE

Tonto Hills Water Company
c/o Don Unthank

January 2, 1997

*outside service ID CK #
1431 18/13*

Engineering services to 1/2/97 for the preliminary design of the tie-in to the City of Scottsdale water system in Desert Mountain, Apache Peak #3.

11/26/96 Mtg w/ Dueker on parameters for design of tie-in 1 hr

11/27/96 Review of info from Dueker 2 hr

12/2/96 Research of Desert Mt. Apache Peak plans, and investigate pipe alignment 6 hr

12/17/96 Mtg w/ Dueker, Covert, & Payne on City requirements for tie-in 3 hr

12/18/96 Field invest. w/ Dueker and Payne 4 hr

12/27/96 Prepare plan of alignment & pump station modifications 8 hr

12/30/96 Presentation to Nelsen, Covert, Dueker 3 hr

Total Hours 27 hr

Engineer 27 hr X \$90.00/hr = \$2,340

*OK
1/5/97
J. K. Kaul*

Mustead Engineering

188 W. Moon Valley Drive
Phoenix, Arizona 85023

(602) 993-9924 Business
(602) 942-2762 Residence

INVOICE

Tonto Hills Water Company
11802 E. Blue Wash Road
Cave Creek, AZ. 85331

outside services

March 11, 1997

Engineering services to 3/11/97 for the revision to preliminary design of the tie-in to the City of Scottsdale water system in Desert Mountain, Apache Peak #3. Revisions required to modify plan for new location of tie-in and alignment of pipeline. The revisions also required research and analysis of Public Utility Easements in Tonto Hills Subdivision across lots 115, and 118.

	Engr	Tech
Research at County Assessor and Recorder Office	6 hr	2 hr
Research at City of Scottsdale	4 hr	
Prepare Exhibit of pipe alignment	4 hr	2 hr
Research and prepare cost estimate	4 hr	
Meeting with client	2 hr	
Totals	20 hr	4 hr

Fee Calculation

Engineer 20 hr X \$90.00/hr = \$1800.00
Technician 4 hr X \$65.00/hr = \$ 260.00
Copies \$18.85 X 1.15¢ = \$ 21.68

Total Due This Invoice = \$2081.68

3/15/97
OK for payment
[Signature]

Hustead Engineering

588 W. Moon Valley Drive
Cave Creek, Arizona 85023

(602) 993-9924 Business
(602) 942-2762 Residence

INVOICE

Tonto Hills Water Company
11802 E. Blue Wash Road
Cave Creek, AZ. 85331

April 8, 1997

attached invoice

Engineering services through April 8, 1997, for design of Tonto Hills Utility Co. tie-in to City of Scottsdale water system at Desert Mountain. Services include preparation of easement and progress on system design. Phase I services were performed and invoiced previously. Specific tasks of phases II and III are presented below.

II. Prepare Easement for Pipe Alignment

Task Description	Engr	Tech	Survey	Cler
1. Prepare exhibit for easement ✓	8	4		
2. Prepare legal description ?	4			2
3. Process w/ City, recorder ?	4			
Subtotal II	16	4		2

III. Prepare Construction Plans & Specs

Task Description	Engr	Tech	Survey	Cler
1. Mtg w/client to determine sizes ✓	4			
2. Design pipeline & service conn ? ✓	4		8	
3. Design reservoir tie-in/BFP ?	8			
4. Design pump sta. modification ✓	8			
5. Prepare construction plans ?	8	50		
6. Prepare specs & cost est. ?		0		
7. Process w/City ?	0			
Subtotal III	32	50	8	0

DENNIS H SAYS THIS WORK ALL DONE
FOR ITEMS II AND III 4/4-97

@ 7,100⁰⁰

+ 12,565

UT-200
11-10-100

Justead Engineering

570 W. Main Valley Drive
Phoenix, Arizona 85023

(602) 993-9924 Business
(602) 942-2762 Residence

INVOICE

IV. Construction Phase Services

Task Description	Engr	Tech	Survey	Cler
1. Assist in contractor selection	0	0		
2. Pre-construction mtg	0	0		
3. Construction staking	0		0	
4. Field Inspect. (3 trips X 6 hr)	0			
5. Pay estimates/ contract adm.	0			0
Subtotal IV	0	0	0	0

Fee Calculation

Phase II

Engr 16hr X \$90/hr = \$ 1,440
Tech 4hr X \$65/hr = \$ 260
Cler 2hr X \$35/hr = \$ 70
Repro = \$ 25

Subtotal II = 1,795 SWB

Phase III

Engr 32hr X \$90/hr = \$ 2,880
Tech 50hr X \$65/hr = \$ 3,250
Survey 8hr X \$115/hr = \$ 920
Cler 0hr X \$35/hr = \$ 0
Repro/ Copies = \$ 50

Subtotal III = 7,100 SWB

Phase IV

Engr 0hr X \$90/hr = \$ 0
Tech 0hr X \$65/hr = \$ 0
Survey 0hr X \$115/hr = \$ 0
Cler 0hr X \$35/hr = \$ 0

Subtotal IV = \$ 0

Total Fee Earned Phase II & III = 8,895 - TOTAL

OK # 1496
4-11-97

Mustard Engineering

588 W. Mecca Valley Drive
Mesa, Arizona 85023

(602) 993-9924 Business
(602) 942-2762 Residence

INVOICE

*Interest
services*

CK# 1502

4-24-97 April 17, 1997

Tonto Hills Water Company
11802 E. Blue Wash Road
Cave Creek, AZ. 85331

Engineering services through April 17, 1997, for design of Tonto Hills Utility Co. tie-in to City of Scottsdale water system at Desert Mountain. Services include preparation of easement and progress on system design. Phase I services were performed and invoiced previously. Specific tasks of phases II and III are presented below. No further work will be done or billed on the assignment until agreement is reached with the City, or so directed by the client.

II. Prepare Easement for Pipe Alignment

Task Description	Engr	Tech	Survey	Cler
1. Prepare exhibit for easement	8	4		
2. Prepare legal description	4			2
3. Process w/ City, recorder	4			
Subtotal II	16	4		2

III. Prepare Construction Plans & Specs

Task Description	Engr	Tech	Survey	Cler
1. Mtg w/client to determine sizes	4			
2. Design pipeline & service conn	6		8	
3. Design reservoir tie-in/BFP	16			
4. Design pump sta. modification	12			
5. Prepare construction plans	16	70		
6. Prepare specs & cost est.	4	0		
7. Process w/City	0			
Subtotal III	58	70	8	0

IV. Construction Phase Services

Task Description	Engr	Tech	Survey	Cler
1. Assist in contractor selection	0	0		
2. Pre-construction mtg	0	0		
3. Construction staking	0		0	
4. Field Inspect. (3 trips X 6 hr)	0			
5. Pay estimates/ contract adm.	0			0
Subtotal IV	0	0	0	0

Fee Calculation

Phase II

Engr	16hr X \$90/hr	= \$ 1,440
Tech	4hr X \$65/hr	= \$ 260
Cler	2hr X \$35/hr	= \$ 70
Repro		= \$ 25

Subtotal II = \$ 1,795

Phase III

Engr	58hr X \$90/hr	= \$ 5,220
Tech	50hr X \$65/hr	= \$ 4,550
Survey	8hr X \$115/hr	= \$ 920
Cler	0hr X \$35/hr	= \$ 0
Repro/ Copies		= \$ 80

Subtotal III = \$10,770

Phase IV

Engr	0hr X \$90/hr	= \$ 0
Tech	0hr X \$65/hr	= \$ 0
Survey	0hr X \$115/hr	= \$ 0
Cler	0hr X \$35/hr	= \$ 0

Subtotal IV = \$ 0

Total Fee Earned Phase II & III = \$12,565

Less Previous Invoices (II & III) = \$ 8,895

Amount Due This Invoice \$ 3,670

Hustead Engineering

568 W. Moon Valley Drive
Phoenix, Arizona 85023

(602) 993-9924 Business
(602) 942-2762 Residence

INVOICE

Tonto Hills Water Company
c/o Mr. Don Unthank

August 13, 1996

Engineering services through 8/13/96 for preliminary analysis of tie-in to City of Scottsdale water system at Desert Mountain, Apache Peak Part Two "A". Phase I of the assignment is to verify capacity in the City's system to deliver the Tonto Hills Water Co. requested flows and estimate construction costs for the tie-in. Services to date include meetings with the City, research of Desert Mountain design records, field investigations, and report preparation.

Engineer

24 hrs X \$90.00 = \$2160.00

PD CR# 133Z
8-15-96

4

SECTION 4-4

Southwest Community Resources, Inc.

March 3, 1998

7100 ^{AS}
COST

Mr. James F. Skane, President
Tonto Hills Utility Company
42602 North Turquoise Lane
Cave Creek, AZ 85331

RE: WATER SUPPLY FOR TONTO HILLS

Dear Mr. Skane:

Enclosed is a proposed Agreement for consulting services to be provided to the Tonto Hills Utility Company by Southwest Community Resources, inc. relative to securing a permanent water supply for the community of Tonto Hills.

The enclosed Agreement is based upon a similar agreement presented to the Town of Carefree. No fees are payable to SCR until the new water supply is secured for Tonto Hills.

Please let me know if you have any questions or need additional information. Please sign and return one fully executed Agreement to my office.

Sincerely,

SOUTHWEST COMMUNITY RESOURCES, INC.

Timothy R. Bray

Timothy R. Bray
President

TRB:rw(118S/61)
Enclosures

Southwest Community Resources, Inc.

AGREEMENT

This Agreement is made and entered into this ____ day of March, 1998, by and between TONTO HILLS UTILITY COMPANY ("Tonto"), and SOUTHWEST COMMUNITY RESOURCES, INC., an Arizona corporation ("SCR").

RECITALS

A. Tonto desires to retain SCR to provide consulting services with respect to:

1. Completing the acquisition of a potable water supply for the benefit of Tonto.

B. SCR desires to provide such consulting services on the terms and conditions set forth in this Agreement.

NOW, THEREFORE, in consideration of the agreements and covenants contained in this Agreement and other valuable consideration, the parties hereto agree as follows:

1. Scope of Agreement. SCR will use its best efforts to acquire up to 70 acre feet of new water, acceptable to Tonto, and, for the benefit of Tonto. This water is to be delivered through the City of Scottsdale pursuant to an Agreement between the City of Scottsdale and Tonto Hills Utility Company. SCR has no obligation to obtain approval of this treat and transport agreement from the City of Scottsdale.

2. Term of Agreement. This Agreement shall commence as of the date hereof, and shall expire on December 31, 1998. Thereafter the term of this Agreement may be extended by the mutual written consent of Tonto and SCR. *EXTENSION THRU 1999 SIGNED BY DON*

3. Fee Structure. There shall be no minimum monthly fee. SCR shall be compensated on the basis of \$100 per acre foot of water, acquired on behalf of Tonto. SCR will earn the fee only when the transaction is completed. The transaction shall be deemed complete when all documents are executed by all parties to the transaction. Tonto will pay SCR consulting fees no later than 30 days following the completion of the transaction.

for the first full year of water supply

4. Reporting. During the term of this Agreement SCR shall report to James F. Skane or his designee, for coordination and approval of services described in this Agreement.

5. Other Employment. SCR, its agents or employees, may be engaged by a third party to perform consulting or other services of any nature and description including, but not limited to, services similar to those rendered pursuant to this Agreement.

6. Independent Contractor. This Agreement does not constitute an employment agreement between Tonto and SCR or any of SCR's employees. It is the parties' intention that SCR shall be an independent contractor and not an employee of Tonto. It is the parties' further intention that any employees hired by SCR shall be solely the employees of SCR and shall not be employees of Tonto.

7. Acknowledgment. Tonto acknowledges that the successful completion of this transaction greatly depends on decisions to be made by parties over which SCR has little or no control, including the City of Scottsdale, the Central Arizona Water Conservation District, the Arizona Department of Water Resources, and the United States, and that there is some risk that, because of an action or a failure to act by one or more of those parties, the water allocation may not be acquired for the benefit of Tonto. In that event, this Agreement shall expire and neither party shall have any liability or obligation to the other.

8. Miscellaneous. Time is of the essence of each and every term of this Agreement. Neither party may assign any of their rights or obligations hereunder without the consent of the other party, which consent will not be unreasonably withheld or delayed. If any litigation arises in connection with this Agreement, the prevailing party shall be reimbursed by the other party for all expenses expended in connection with such litigation, including reasonable attorneys' fees, such expenses to be fixed by the Court and added to the judgment in such litigation.

SOUTHWEST COMMUNITY RESOURCES, INC.,
an Arizona corporation

By: Timothy R. Bray
Timothy R. Bray, President

TONTO HILLS UTILITY COMPANY

By: [Signature]
Its: President

5

SECTION 4-5

P. -1

J. Stanley Edwards
Attorney at Law

P. O. Box 7680
Cave Creek, Arizona 85327

Physical Address:
2415 East Rockaway Hills Road
Cave Creek, Arizona
(Also Admitted in Colorado)

Phone: (602) 465-9600
Fax: (602) 465-9700
E-Mail: jstanley.edwards@azbar.org
Pager: (602) 407-4125

January 5, 2000

Don Unthink, President
Tonto Hills Utility Company
11802 East Blue Wash Road
Cave Creek, Arizona 85331

Re: Legal Services

Dear Don:

Please accept this letter as my statement to you in the amount of \$2,364.00 for legal services rendered and costs advanced from through January 1, 2000. Of the above amount \$2,354.00 represents 21.4 hours of legal service at my standard hourly rate of \$110.00 with the remaining \$10.00 representing costs advanced on your behalf. A breakdown of services and costs follows:

12-02 various tcw Harry Howe re THUC, brief review of 89 page fax from Harry, various tcw with Judy re missing pages - 1.3

12-03 tcw Don re history, status of loan - .5

12-05 tcw Don re meeting, travel to and attend mtg at Don' home, observe various well sites and equipment, obtain

cktt 2238
1-10-00

P. 2

history of THUC, bring back various files for review, begin review of files - 7.8

12-07 tcw Julie Peru re documents required - referred to attorney, tcw Marily Benesch of Snell & Wilmer - said she'd check things out and get back to me, tcw Don re status, advised of problem of mtg of 12-7 without Sutter's waiver, finish review of documents, begin preparation of opinion letter - 7.1

12-08 internet review of superior court files, US Bankruptcy court files, US District court files for adverse data on THUC, no pending issues found, tcw DU re same, prepare certificate for signature of THUC secretary, complete review of documents and opinion letter - 3.2

12-09 mtg with Don at his office, review documents, discuss status - .3

12-15 tcw Don re status, still no ACC approval - .2

Total 21.4 hours

Postage/Copying Costs \$10.00

Total \$10.00

Please note that effective January 1, 2000 my hourly rate will increase to \$125.00. This is the first increase in my hourly rate since the late 1980s. If you have any questions concerning this matter, please do not hesitate to contact me at your convenience.

Very truly yours,

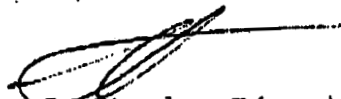

J. Stanley Edwards
Attorney at Law

JSE/j

cc: Keith Shreeve, Treas.

6

SECTION 4-6

BLUCOR

CONTRACTING

Grading • Paving • Water • Sewer

Cast in place pipe 

PROPOSAL(Revised)

September 4, 2002

To: **Bill Weber**
Desert Mountain Properties
10550 E. Desert Hills Drive
Scottsdale, AZ 85280

From: Gordon Bluth

Project: **Booster Pump Station Modification - Pump Station #94**

A-N West Engineering Plans Dated:03-11-02 & Wright Engineering Plan Dated: 03-13-02

<u>Description</u>	<u>Qty</u>	<u>Unit Price</u>	<u>Total</u>
Purchase & Install New Piping/Pumps	1	LS	\$ 30,422.00
Purchase & Install Electrical Modifications (Specification per above plans)	1	LS	\$ 66,000.00
		TOTAL	\$ 96,422.00*

Includes: Removal and reinstallation of a portion of the metal roofing; removal of old piping and pumps; installation and testing of new piping and pumps; as per plan removal of old electrical equipment and installation of new electrical equipment; wiring and rewiring of modified electrical equipment.

Excludes: Engineering; staking; bond; permits; taxes; fees; utility company costs & fees; no new RTU hardware or programming; temporary lighting & power and devegetation or revegetation.

*Note: This bid is based on installation of D.I fittings and like kind electrical equipment, if a specific type piping or electrical equipment is specified in final approved plans, owner is responsible for the difference.

Gilbert Office: 610 N. Gilbert Rd., #317 • Gilbert, AZ 85234
(480) 813-6465 • Fax (480) 813-6506

Mailing Address: 402 E. Campbell • Gilbert, AZ 85234

Desert Mountain Construction Office: (480) 595-8073 • Fax (480) 488-6120



Gilbert

PUMP & EQUIPMENT CO.

P.O. BOX 20216
 1475 EAST ELWOOD STREET
 PHOENIX, ARIZONA 85036-0216
 PH: 602-276-5599 FAX: 602-276-5592

September 3, 2002

Mr. Wade Cooke
 Scottsdale Desert Mountain
 10550 East Desert Hills Drive
 Scottsdale, Arizona 85262

Re: Booster and electrical changes for The Tonto Hills Water Company

Dear Wade

Per your request and the specifications and drawings furnished to us we submit the following bid for your consideration.

1. Furnish and install 2 new 40 horsepower Grundfos submersible pumps to be mounted in the new pump barrels. These pumps are as shown on the plans provided to us.
2. Furnish and install the new piping, valves and fittings as shown on the drawings provided to Gilbert Pump.
3. Removal of the existing pumping equipment, valves and fittings including transporting these removed units back to the City of Scottsdale.
4. After the installation has been completed we will paint the outside of the piping, pump barrels, valves and fittings with high quality semi gloss paint.

The delivery of these units will be approximately three to four weeks after placement of an order with the manufacturer. The valves and fittings should not take more than a couple of weeks after ordering.

We understand that this work must be done at night or at least during any period that the station service flow is at it's minimum. Also the plans call the system to remain in service during this construction, but we cannot see where this can be accomplished with out some period of total shut down.

The total cost for this work will be \$32,976.00 including applicable contract taxes.

Also per your request we submit the following quoted price for the electrical work at this booster station site.

Furnish and install the new electrical gear required to operate the new submersible booster pumps. We also include the new disconnect to be mounted in an existing cabinet. Our quote covers all required conduit, wire, and electrical fittings required to install the new equipment and to connect the electrical to the booster pumps.

ARIZONA STATE CONTRACTOR'S LICENSES

L-11 NO 070152 • L-29 NO 070153 • A-12 NO. 070150 • A-16 NO. 070151 • C-29 NO. 018210 • C-11 NO. 018209

Our Electrical work will be subcontracted to Keller Equipment Company. Gilbert Pump and Keller Equipment Co. have completed several projects together for both the City of Scottsdale and other municipal users.

The total cost for this new electrical equipment will be \$69,329.00 including applicable contract taxes.

This electrical equipment will take approximately 10 to 12 weeks to manufacture and approximately one-week shipping time after release of the order to the factory.

Our exclusions are as follows.

1. Bonding
2. Concrete work of any nature
3. Permits or fees that may be required from various entities

The total cost for acceptance of both of the above quotes will be \$102,305.00

Thanks, for the opportunity to provide you with this quotation.

Should you have any questions please call.

Very truly yours,
Gilbert Pump & Equipment Co.

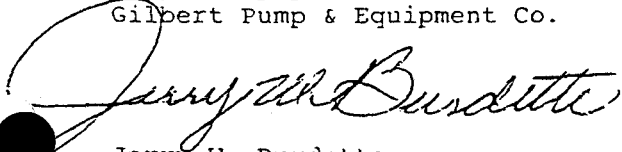

Jerry W. Burdette
Contracting Manager

PUMP STATION IMPROVEMENT ESCROW ACCOUNT AGREEMENT

This Pump Station Improvement Escrow Account Agreement ("Agreement") is entered into as of NOVEMBER 13, 2002, by and between Desert Mountain Properties Limited Partnership, a Delaware limited partnership ("DMP"), First American Title Insurance Company, a California corporation licensed to do business as an escrow company in Arizona ("Escrow Agent"), and Tonto Hills Utility Company ("Tonto Hills").

Recitals

- A. DMP has previously constructed Pump Station No. 94, which is in the vicinity of the common boundary line separating the Desert Mountain planned community from the Tonto Hills subdivision.
- B. DMP has previously agreed, with the concurrence of the City of Scottsdale, to allow Tonto Hills, for the benefit of its customers residing within the Tonto Hills subdivision, to tie into the public potable water supply system within Desert Mountain, at a point near Pump Station No. 94, in order to provide potable water service to Tonto Hills, subject to Tonto Hills paying for all incremental costs of upgrading the pumping capacity within Pump Station No. 94 necessary to serve Tonto Hills' purposes, without causing a degradation in the quality or quantity of water service to Desert Mountain residents, or increasing noise emanating from the pump station.
- C. Subsequent to such agreement with Tonto Hills, DMP has been advised by the City of its requirement to make further improvements to Pump Station No. 94 for purposes of increasing pumping capacity to service Desert Mountain residents, independent of the needs of Tonto Hills and its residents. Tonto Hills and DMP have agreed to share the actual construction costs of those improvements described in the Summary of Work attached hereto as Exhibit "A," to be constructed in accordance with A-N West's plans dated March 11, 2002, and specifications dated February 4, 2002 (the "Improvements") on a 50-50 cost-sharing basis, with such cost-sharing arrangement to include hard construction costs relating to the Improvements. Excluded from the cost-sharing arrangement are design, engineering, and construction management services, whether incurred or to be incurred, which shall be paid solely by the party incurring such costs.
- D. DMP and Tonto Hills desire to place in an escrow account, and Escrow Agent is agreeable to holding, segregated funds set aside for purposes of ensuring the completion of the Improvements, pursuant to the directions to Escrow Agent, and terms and conditions hereof, as set forth below.

Agreement

1. Funds. Within thirty (30) days following execution hereof, DMP and Tonto Hills shall each deposit with Escrow Agent, the cash sum of \$50,000 (the "Funds"), which amount, pursuant to a bid attached hereto as Exhibit "B," is believed to be approximately 104% of the amount sufficient to complete all of the Improvements. Escrow Agent agrees to hold the Funds

in Escrow as hereinafter directed, and to make disbursements, including partial disbursements, of the Funds strictly in compliance with the provisions set forth below.

2. Interest-Bearing Account. Escrow Agent agrees to place and thereafter maintain the Funds, upon receipt, in a segregated interest-bearing account with a federally or state chartered financial institution acceptable to DMP, but as to which neither DMP nor Tonto Hills have any withdrawal authority. DMP and Tonto Hills each agree to pay one-half of Escrow Agent's and/or such financial institution's reasonable and customary fee (estimated at \$25) to establish such a segregated interest-bearing account, and jointly authorize Escrow Agent to reimburse itself from the Funds for such amount. All accrued interest shall automatically be added to the Funds and shall thereupon be considered to be part of the Funds for all purposes under this Agreement.

3. Escrow Period. DMP has contracted with, or is in the process of contracting with, an Arizona licensed contractor ("Contractor") to construct the Improvements. The estimated time for completion of the Improvements is 120 days following commencement of the work. Inasmuch as the improvement plans for the Improvements require the review and approval of appropriate personnel within the City of Scottsdale, the above date is an estimate and is contingent upon scheduling constraints and factors outside the control of DMP. Escrow Agent agrees to hold the Funds, inclusive of any remaining balance of the Funds following any disbursements as provided below, until a date that is no earlier than December 1, 2003. At any time thereafter, provided a Notice of Completion had not previously been delivered to Escrow Agent pursuant to Paragraph 5 below, then without any demand of either DMP or Tonto Hills, Escrow Agent is hereby irrevocably instructed to disburse directly to each such party, in equal shares, notwithstanding any conflicting instructions or directions from either DMP or Tonto Hills, whatever portion of the Funds Escrow Agent then holds.

4. Draw Disbursements. Inasmuch as the Funds serve the purpose of ensuring the timely payment of the Improvements, Escrow Agent further agrees to disburse payments directly to Contractor, by way of progress payments, upon receipt of DMP's sole written instruction ("Draw Instruction") to do so. Such Draw Instruction shall identify Contractor and its address for disbursement purposes, and shall be accompanied by a written certification by an Arizona licensed registered engineer or architect certifying the disbursement to be paid to Contractor reflects a "percentage complete" proportionate share of the Funds allocable to that portion of the Improvements actually completed as of the date the Draw Instruction is delivered. DMP shall concurrently provide a copy of each Draw Instruction to Tonto Hills. In no event shall Escrow Agent pay any such disbursement to DMP or Tonto Hills, or to any agent of either party.

5. Release of Remaining Funds Upon Completion. Promptly upon Escrow Agent's receipt of a recorded Notice of Completion evidencing that the Improvements have been completed in accordance with approved plans therefor ("Notice of Completion"), Escrow Agent shall release and return directly to both DMP and Tonto Hills, or their respective designees, in equal shares, the then remaining balance of the Funds, if any.

6. Escrow Fees. For performing its services hereunder, DMP and Tonto Hills have each paid Escrow Agent, concurrently upon execution hereof, a fee in the amount of \$150 each, by way of a one-time escrow fee, receipt of which is hereby acknowledged.

7. Cost Overruns. The bid attached hereto as Exhibit "B" is from Blucor Contracting ("Blucor"), a reputable contractor who DMP is planning, but has not yet committed, to use to construct the Improvements. Should DMP not wish to engage Blucor, or should Blucor be unwilling or unable to perform or complete such services, DMP shall employ the next highest bidder, Gilbert Pump & Equipment Co., whose bid is attached hereto as Exhibit "C." If, for any reason, such contractor is unwilling or unable to perform or complete such services as and when required by DMP, then DMP and Tonto Hills agree to immediately confer, and select an alternate contractor, rebidding the work, or any then remaining portion, if necessary. In the event the actual costs of completing the Improvements exceed the Fund, whether through original selection of another contractor, procuring substitute performance upon default, cost overruns or other factors beyond the control of DMP and Tonto Hills, then DMP and Tonto Hills shall immediately deposit with Escrow Agent, within 30 days following DMP's written request therefor, on a 50-50 basis, additional funds sufficient to cover DMP's good faith estimate of such increased construction costs.

8. Construction Coordination and Other Excluded Costs. DMP agrees to provide any and all necessary construction oversight, legal, and accounting services, at DMP's sole cost and expense, utilizing employees or consultants of its choosing, to implement and/or carry out the intent of this Agreement and to oversee the construction of the Improvements. Any such costs incurred by DMP shall not be subject to the cost-sharing arrangement provided for herein. Further, both DMP and Tonto Hills acknowledge and agree that costs each party has incurred to date, or may hereafter incur, relative to design, engineering, legal, accounting, or other costs, including Tonto Hills' cost of connecting Pump Station No. 94 to its water storage and delivery system, likewise shall not be eligible for reimbursement or cost-sharing under this Agreement or any other arrangement.

9. Connection; Removal of Temporary Improvements. No later than thirty (30) days following the date of completion of the Improvements, Tonto Hills shall, at its sole cost and expense, make all necessary connections, within duly recorded easements therefor, from Pump Station No. 94 to its water storage and delivery system. Tonto Hills shall also, at its sole cost and expense, and no later than thirty (30) days following the date of completion of the Improvements, disconnect the temporary water supply line currently servicing the Tonto Hills subdivision. Tonto Hills shall remove any and all of the temporary improvements on, or within view of, real property located within the Desert Mountain planned community, and restore any real property disturbed by such temporary improvements to their former condition. Any and all licenses or other permissive rights previously granted Tonto Hills, or any third party acting on behalf of the Tonto Hills residents, shall automatically be deemed terminated following removal of the temporary water supply line and temporary improvements, and of no further force or effect.

10. Review of Improvement Plans. Tonto Hills and DMP have employed experts and/or other representatives of their own choosing. Each such party acknowledges that they have had adequate opportunity to review, and provide input as to, the design and proposed increased capacity of the Improvements and have each, independently of the other, determined such Improvements, as identified in the relevant improvement plans and specifications, are sufficient for each such party's purposes and intended use. Consequently, provided the Improvements are constructed and completed in accordance with the improvement plans and

specifications, DMP releases Tonto Hills and Tonto Hills releases DMP from any claim or demand that the Improvements, once completed, are inadequate for either party's purposes or intended use, and each party acknowledges that no representations or warranties, express or implied, can or shall be attributed to, or will be asserted against the other party.

11. Notices. Any and all notices required or permitted to be given pursuant to terms of this Agreement shall be in writing addressed to the other party and Escrow Agent at the addresses set forth below, and shall be delivered by U.S. mail (with postage prepaid), facsimile transmission (subject to telephonic confirmation of receipt), overnight courier, or personal delivery and, unless by mail, shall be deemed delivered upon actual receipt. If delivered by mail, such notices shall be deemed delivered upon the third business day following deposit in the U.S. mail. The mailing addresses and facsimile numbers for the respective parties are set forth as follows:

- If to Desert Mountain Properties Limited Partnership, Attn: Rich Yehling, 10550 East Desert Hills Drive, Scottsdale, Arizona 85262 (facsimile: 480-595-4001);
- If to Tonto Hills Utility Company, Attn: Don Unthank, 11802 East Blue Wash Road, Cave Creek, Arizona 85331 (facsimile: 480-922-9872);
- If to (or copied to) Escrow Agent, Attn: Janette Waller, 23341 North Pima Road, Suite 137, Scottsdale, Arizona 85255 (facsimile: 480-563-9092).

12. Attorney's Fees. Should any party or parties to this transaction bring a legal action to enforce or interpret the terms of this Agreement, the non-prevailing party or parties shall be responsible for paying the attorney's fees and costs of the prevailing party or parties. Escrow Agent reserves all rights to interplead the Funds if a dispute arises which precludes Escrow Agent from disbursing or returning the funds pursuant to the irrevocable instructions set forth above.

13. Amendments. This Agreement may not be amended or otherwise modified other than by written amendment executed by all parties hereto.

IN WITNESS WHEREOF, this Agreement is executed by the parties hereto as of the date first set forth above.

DESERT MOUNTAIN PROPERTIES
LIMITED PARTNERSHIP,
a Delaware limited partnership

TONTO HILLS UTILITY COMPANY,
an Arizona corporation

By: Richard Yehling
Richard Yehling
Chief Financial Officer

By: Donald J. Unthank
Name: DONALD J. UNTHANK
Title: PRES.

ACCEPTED:

FIRST AMERICAN TITLE INSURANCE
COMPANY, a California corporation

By: 

Janette Waller

Branch Manager and Escrow Agent

ESCROW ACCT # 2074050794

SECTION 01010

SUMMARY OF WORK

1.0 GENERAL

The project consists of the upgrade of a City of Scottsdale Booster Pump Station. Pump Station #94 is located near the intersection of 111th Place and 112th Place in the northeast corner of the Desert Mountain Development.

Basic elements of work for the Booster Pump Station will include:

- 2-260 gpm Submersible Vertical Turbine Pumps.
- Installation of assorted piping, valves, and appurtenances.
- Removal of existing submersible pumps & Piping.
- Electrical controls and equipment

The above items work along with construction requirements are described and defined herein from Division 1 through 16 and in the Uniform Standard Specifications for Public Works construction sponsored and distributed by the Maricopa Association of Governments (MAG) along with the MAG Uniform Standard Details and the City of Scottsdale MAG supplements (latest revisions).

City of Scottsdale General Notes are included in the drawings and shall be representative, where applicable or unless noted otherwise, to all plan sheets. Any supplements or revisions to the MAG Standard Specifications that have been included in the individual sections for construction items in Divisions 1 through 6 shall be considered revised or supplemented as noted.

****END OF SECTION****



First American Title Insurance Company

23341 North Pima Road, Suite 137 • Scottsdale, Arizona 85255
(480) 563-9034 • Fax: (480) 563-9092

FAX TRANSMISSION

DATE: April 10, 2003

TO: Karen A. Kobzan @ Desert Mountain Properties - via fax to: (480) 595-4250
Rich Yehling @ Desert Mountain Properties - via fax to: (480) 595-4001
Don Unthank @ Tonto Hills Utility Company - via fax to: (480) 922-9872

FROM: Janette Waller, Branch Manager
First American Title

ESCROW NO.: 207-4050794

RE: Escrow Account Agreement

SPECIAL INSTRUCTIONS:

Attached please find a copy of the additional funds which have been deposited into escrow by Tonto Hills Utility Company. Please contact me with any questions.

Number of pages (including this cover sheet): 3

Original Will be sent via regular mail
 X Will not be sent via regular mail

If original is needed, please contact sender. Thank you.

If transmission of all pages is not complete, please call:
Janette Waller at (480) 563-9034

PLEASE NOTE: SHOULD ANY OF THESE PAPERS REQUIRE AN ORIGINAL SIGNATURE. PLEASE TAKE A XEROX COPY BEFORE SIGNING. WE WILL "NOT" ACCEPT AN ORIGINAL SIGNATURE ON FAX PAPER. THANK YOU FOR YOUR COOPERATION IN THIS MATTER.



First American Title Insurance Company
23341 North Pima Road, Suite 137 Scottsdale, AZ 85255

PR: 4000

Ofc: 4207

DATE: 04/10/2003

RECEIPT NO.: 20784160

FILE NO.: 207-4050794

RECEIPT FOR DEPOSIT

FUNDS IN THE AMOUNT OF: \$17,250.00

WERE RECEIVED FROM: Tonto Hills Utility Company

CREDITED TO THE ACCOUNT OF:

TYPE OF DEPOSIT: Personal Check

REPRESENTING: Miscellaneous Deposit

Comments:

Property Location:

DEPOSITED CHECK INFORMATION:

Check No.: 2945
ABA No.: 122105744
Bank Name: Compass Bank
Account Number: 600321024

BY: Janette Waller, 04/10/2003

ESCROW OFFICER: Janette Waller

"The validity of this receipt, for the deposit referenced,
is subject to clearance by the depository financial institution and credit to our account."

Customer Copy

2074050794

TONTO HILLS UTILITY COMPANY
37611 N. CAVE CREEK RD., STE. A
CAVE CREEK, AZ 85331

2945

DATE 4-8-03

91-674/1221
595

PAY
TO THE
ORDER OF

First American Title Insurance Co.

\$ 17,250.00

Seventeen Thousand Two Hundred Fifty Dollars & 00/100

DOLLARS



Compass Bank
Scottsdale, Arizona

TWO SIGNATURES REQUIRED
FOR \$500.00 OR MORE

FOR Enclosed 2074050794

[Signature]
[Signature]

⑈002945⑈ ⑆122105744⑆ 6003201024⑈

TONTO HILLS UTILITY CO.
Transaction Detail by Account
 December 2002

Type	Date	Num	Name	Memo	Cir	Split	Amount	Balance
Checking								
Check	12/4/200	2857	RSC		X	Equipment ...	-1,101.56	-1,101.56
Check	12/4/200	2858	CAP		X	Water Deliv...	-792.00	-1,893.56
Check	12/4/200	2859	Az Dept of Envir...		X	Water Testi...	-471.49	-2,365.05
Check	12/4/200	2860	MARICOPA CO...	219121150	X	Licenses an...	-450.00	-2,815.05
Check	12/5/200	2865	U. S. POSTOFF...		X	Postage	-74.00	-2,889.05
Deposit	12/9/200			Deposit	X	Fees	3,098.56	-209.51
Deposit	12/9/200			Deposit	X	Fees	350.81	560.32
Check	12/9/200	2866	FOOTHILLS AC...		X	Accounting	-600.00	-39.68
Check	12/9/200	2867	U. S. POSTOFF...		X	Postage	-2.49	-42.17
Check	12/9/200	2868	LEGEND		X	Water Testi...	-15.00	-57.17
Check	12/11/20	2869	FIRST AMERIC...	inv 89477	X	Prepaid Ex...	-50,000.00	-50,057.17
Deposit	12/11/20			Deposit	X	Founders B...	10,500.00	-39,557.17
Deposit	12/11/20			Deposit	X	Prepaid Ex...	39,559.95	2.78
Check	12/12/20			Deposit	X	Fees	2,331.05	2,333.83
Check	12/16/20	2853	U. S. POSTOFF...		X	Postage	-39.60	2,294.23
Check	12/16/20	2854	Ron Shields		X	Outside Ser...	-2,000.00	294.23
Deposit	12/18/20			Deposit	X	Fees	2,431.96	2,726.19
Check	12/23/20	2870	AZ DEPT OF R...		X	Sales	-543.86	2,182.33
Deposit	12/26/20			Deposit	X	Fees	1,570.65	3,752.98
Check	12/30/20	2871	CITY OF SCOT...		X	Water Deliv...	-131.47	3,621.51
Check	12/30/20	2872	Harry L. Howe		X	Legal Fees	-54.30	3,567.21
Check	12/30/20	2876	RSC		X	Equipment ...	-302.81	3,264.40
Paycheck	12/31/20	2878	FREDERICK, D...		X	-SPLIT-	-92.23	3,172.17
Paycheck	12/31/20	2879	FREDERICK, L...		X	-SPLIT-	-138.40	3,033.77
Paycheck	12/31/20	2880	Unthank, Donald		X	-SPLIT-	-92.35	2,941.42
Paycheck	12/31/20	2881	FREDERICK, L...		X	-SPLIT-	-214.91	2,726.51
Check	12/31/20	2877	Cody Bayuk		X	Outside Ser...	-69.00	2,657.51
General Journal	12/31/20			transfer	X	Compass T...	-2,444.60	212.91
Total Checking							212.91	212.91
Compass Transfer Account								
General Journal	12/31/20			transfer fro...	X	Checking	2,444.60	2,444.60
General Journal	12/31/20				X	Prepaid Mis...	-2,294.71	149.89
Total Compass Transfer Account							149.89	149.89
Founders Bank Money Mkt								
Deposit	12/11/20			Deposit	X	Checking	-10,500.00	-10,500.00
Deposit	12/31/20			Interest	X	Interest Inc...	43.88	-10,456.12
Total Founders Bank Money Mkt							-10,456.12	-10,456.12
Accounts Receivable								
General Journal	12/31/20		SKANE LOT 23	to adj a/r		Fees	-238.79	-238.79
Total Accounts Receivable							-238.79	-238.79
Prepaid Expenses-Other								
Check	12/11/20	2869	FIRST AMERIC...			Checking	50,000.00	50,000.00

Handwritten: 137 ESTERON FARM...
 50000.00

7

SECTION 4-7

Exhibit "C-1"
WATER NEED REPORT
(For Non-Residential Development Only)

Owner name: Tonto Hills Utility Company

Date: 25 JUNE, 2002

Project Name: Agreement for Treatment and Transportation of Water Delivered Through the CAP Canal
 Between the City of Scottsdale and Tonto Hills Utility Company

Agreement Number: 1999-135-COS

Fee Calculation Table:

(1)	Total capacity desired for use in a Calendar Year	gallons / year	9,775,530
(2)	Total capacity purchased prior to this date for use in a calendar year	gallons / year	0
(3)	Additional capacity to be purchased for use in a calendar year (Line (1) minus line (2))	gallons / year	9,775,530
(4)	Divide line (3) by the number of days in a year		365
(5)	Additional capacity to be purchased (Average Daily Use)	gallons / day	26,782
(6)	Water Development Fee in effect at this time for Zone B-E in Dollars per gallon / day		\$6.61
(7)	Sub-Total Fees (multiply line (5) by line (6))		\$177,029.02
(8)	2.04% Administration Fee (multiply line (7) by 0.0204)		\$3,611.39
(9)	TOTAL FEES (line (7) plus line (8))		\$180,640.41

I am an officer of the above referenced company and I have prepared the above calculations.
 I am aware of the penalties and fines that will be enforced against the company, if the average annual water usage in any year exceeds the quantity purchased by ten percent (10%) or more.

TONTO HILLS UTILITY COMPANY

BY: *Donald J. Unthank*
 Signature

President
 Title

Date: 6/25/02

BY: Donald J. Unthank
 Typed Name of party signing

Phone Number: 480-488-0253
 Home
480-948-5030
 Office

MAIL WITH CHECK TO: Water Resources Department
 City of Scottsdale
 9388 E. San Salvador Drive
 Scottsdale, Az 85258

=====
CITY OF SCOTTSDALE
7447 E. INDIAN SCHOOL ROAD
SCOTTSDALE, AZ 85251
488-312-2588
ONE STOP SHOP

REG-RECEIPT:02-0042575 C:Jun 25 2002
CASHIER ID:014 2:15 pm A:Jun 25 2002
=====

7165 DEV-WTR SYS FEE-NON 26681	\$177,829.02
7166 DEV-WTR SYS NON-RES 26681	\$3,611.39

TOTAL DUE \$180,640.41
RECEIVED FROM:
TONTU HILLS UTILITY

CHECK: \$180,640.41

TOTAL TENDERED \$180,640.41

CHANGE DUE \$0.00
=====

=====
HAVE A NICE DAY!
=====

City of Scottsdale Cash Transmittal

Transmittal # : 26601

Transmittal Date : 6/25/2002

Received From :

Bill To :

TONTO HILLS UTILITY COMPANY
37611 N CAVE CREEK RD STE A
CAVE CREEK, AZ 85331
480-488-0253

TONTO HILLS UTILITY COMPANY
37611 N CAVE CREEK RD STE A
CAVE CREEK, AZ 85331
480-488-0253

Reference # : 1999-135-COS

Paid Date : 6/25/2002

Address : NA

Payment Type : CHECK

MCR :

Subdivision :

Lot # :

Marketing Name :

BMP :

QS :

Water Zone : E

County : NO

Metes/Bounds : NO

Water Type :

Sewer Type :

Gross Lot Area : 0

NAOS Lot Area : 0

Net Lot Area : 0

of Units : 1

Density :

Meter Size :

Owner Information :

CITY OF SCOTTSDALE - WATER RESOURCES
9212 N 94TH ST
SCOTTSDALE, AZ 85258
480-312-5827

Code Description	Additional	Qty	Amount	Account Number
7165 WATER SYS FEE-NON/RES-ZONE B-E		1	\$177,029.02	621-00621-47202
7166 WTR SYS NON/RES ADMIN FEE-ZONE B		1	\$3,611.39	621-00621-47405
		Total	\$180,640.41	

26601/TONTO HILLS UTILITY
JUN 25 2002/2:15 PM...
CASH PROCESS DATE: JUN 25 2002
82-8842575
\$ 180640.41

Applicant Signature

(When a credit card is used as payment I agree to pay the above total amount according to the Card Issuer Agreement.)

TO HAVE WATER METER SET - CALL 312-5650 AND REFER TO TRANSMITTAL # 26601

8

SECTION 4-8



United States Department of the Interior

BUREAU OF RECLAMATION

Phoenix Area Office
PO Box 81169
Phoenix, Arizona 85069-1169

IN REPLY REFER TO
PXAO-1500
ENV-6.00

JUN 16 2000

Mr. Don Unthank
Tonto Hills Utility Company
11802 East Blue Wash Road
Cave Creek, Arizona 85331

Subject: Request for Additional Funding to Cover Environmental Staff Costs Required for Oversight of the Environmental Assessment (EA) Titled "Central Arizona Project Water Assignment from BHP Copper, Inc., to Tonto Hills Utility Company"

Dear Mr. Unthank:

Reclamation personnel initially estimated they would incur a cost of \$5,800 for overseeing and reviewing your consultants (SWCA, Inc.) work to obtain the required environmental clearance to approve the proposed Central Arizona Project (CAP) Water Assignment from BHP Copper, Inc. to Tonto Hills Utility Company. Our latest accounting shows staff charges have exceeded the initial payment you provided by \$2,500.

These charges were the result of recent amendments to the Section 106 consultation process involving Traditional Cultural Properties (TCPs). Under the new regulations, all Native American Tribes affected by a Federal project, no matter the size of the project, must be consulted on impacts to TCPs. The Tonto Hills EA work required our archaeologist to consult with seven different Indian Tribes. In addition, extensive coordination efforts among Reclamation, the Hopi Tribe, Tonto Hills Utility Company (THUC), and your consultant were needed to allow Hopi tribal members the opportunity to visit Tonto Hills. The Tribe requested the site visit to determine if TCPs were present, and if adverse impacts to TCPs would occur from the proposed action.

Because of the unanticipated level of coordination required by the TCP consultations, our costs for compliance exceeded our original estimate. We respectfully request that you submit an additional \$2,500 deposit to cover these required costs. We would appreciate your prompt attention to this request. Please send your payment to the address shown below:

Bureau of Reclamation
File No. 91547
P.O. Box 60000
San Francisco, CA 94160-1547

Please reference both the "Agency Locator Code 14060905" and "Cost Authority No. A1R-1753-89P7-300-00-0-0-3" on your remittance when making your payment. A copy of your remittance should also be sent to this office, Attention: PXAO-3000, to the address listed on the letterhead above.

Thank you for your attention to this matter. Should you have any questions, or if you would like more details regarding the charges accumulated to date, please contact Mr. Shane Brady, Environmental Protection Specialist, at 602-216-3863, or Mr. Jon Czaplicki, Archaeologist, at 602-216-3862.

Sincerely,

A handwritten signature in cursive script, appearing to read "Carol Lynn Erwin".

Carol Lynn Erwin
Area Manager

Southwest Community Resources, Inc.

May 10, 1999

Mr. Don Unthank
President
Tonto Hills Utility Company
11802 East Blue Wash Road
Cave Creek, AZ 85331

RE: Bureau of Reclamation - Cost Reimbursement for
BHP Copper Water Transfer

Dear Don:

Enclosed is a draft letter to the Bureau of Reclamation
regarding their request for \$5,800 for the purpose of
establishing a cost reimbursement account relative to the
transfer of BHP Copper CAP water to the Tonto Hills Utility
Company.

I recommend that you forward the \$5,800 check along with this
Transmittal letter as soon as possible. Please note that a
copy of the transmittal letter and check should be sent to the
PX AO - 1500 address.

Sincerely,

SOUTHWEST COMMUNITY RESOURCES, INC.

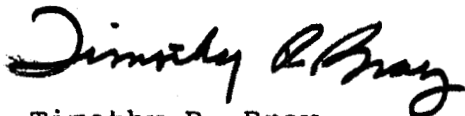

Timothy R. Bray
President

TRB:rw(121S/54)

Encl.

D R A F T

May 10, 1999

*VOID
250000 AVOIDED
LATER DATE*

United States Department of the Interior
Bureau of Reclamation
File No. 91547
P. O. Box 6000
San Francisco, CA 94160-1547

RE: Environmental Clearance for proposed Transfer of BHP
Copper Company's (BHP) Central Arizona Project (CAP)
Water Allocation to the Tonto Hills Utility Company

Dear Sir:

In response to your letter of April 29, 1999, signed by Carol Lynn Erwin, Area Manager, Phoenix, Area Office, please find our remittance for \$5,800. The Tonto Hills Utility Company wishes to establish a separate cost reimbursement account, as referenced in your 4/29/99 letter, relative to the above referenced transaction.

Sincerely,

Don Unthank
President

cc: USDO I
Bureau of Reclamation
Phoenix Area Office
Attn: PX AO - 1500
P. O. Box 81169
Phoenix, AZ 85069-1169

9

SECTION 4-9



CENTRAL ARIZONA PROJECT
 P.O. Box 42447
 Phoenix, AZ 85080-2447

Invoice

CALL TO: Attn: Accounts Payable
 TONTO HILLS UTILITY COMPANY
 MR JIM SKANE
 PRESIDENT
 42602 N TURQUOISE LANE
 CAVE CREEK AZ 85331

NUMBER 10440
 BILL DATE 15-OCT-01
 DUE DATE 20-NOV-01

CUSTOMER NUMBER 1385

DESCRIPTION	QTY	UOM	UNIT COST	TOTAL
1ST HALF SEMIANNUAL 2002 CAPITAL CHARGE	71	A/F	21.50	1,526.50
TOTAL DUE				\$1,526.50

*INSERTED INTO
 4-9 ON 7-2-04*

*pd
 check # 2646
 11/15/01*

SPECIAL INSTRUCTIONS

SEMIANNUAL M&I WATER SERVICE CAPITAL CHARGE

Refer questions to Financial Services 623-869-2149 • inquiries@cap-az.com

REMIT TO:
 CENTRAL ARIZONA PROJECT
 FINANCIAL SERVICES
 PO BOX 42447
 PHOENIX, AZ 85080-2447

NUMBER 10440
 BILL DATE 15-OCT-01
 DUE DATE 20-NOV-01

AMOUNT DUE: \$1,526.50

CUSTOMER NUMBER 1385

PAYMENT:

If you have made any changes on the back of this stub please check this box.

PLEASE RETURN THIS PORTION WHEN MAILING YOUR PAYMENT

Southwest Community Resources, Inc.

January 16, 2002

Mr. Donald Unthank
President
Tonto Hills Utility Company
11802 East Blue Wash Road
Cave Creek, Arizona 85331

RE: Payment for BHP CAP Water

Dear Don:

Tom McCann, legal counsel for the Central Arizona Water Conservation District "CAWCD" called to confirm that the final amount due for your 71 acre feet of CAP water is \$25,985.14. This payment to CAWCD should be made immediately after the Maricopa County Superior Court validates the assignment of BHP Copper CAP water to the Tonto Hills Utility Company. This court action is scheduled for February 22, 2002.

Southwest Community Resources will send you a statement for \$7,100 relative to our consulting agreement immediately following the February 22, 2002 court action.

Please let me know if you need any additional information.

Sincerely

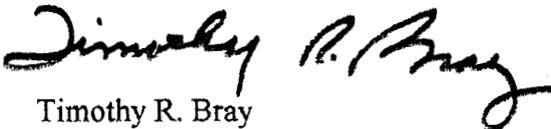
Timothy R. Bray

CC: Leonard Dueker

Received: 2/25/ 2; 9:51PM;
FEB-25-2002 16:10

=> J. STANLEY EDWARDS; #2

P.02

FILED
2-22-02 2:40 pm
MICHAEL K. JEANES, Clerk
By W. Bobrowski
Deputy

COPY

1 SCOTTSDALE CITY ATTORNEY'S OFFICE
2 David A. Pennartz, City Attorney
3 3939 Drinkwater Blvd.
4 Scottsdale, Arizona 85251
5 Telephone: (480) 312-2405
6 Fax: (480) 312-2548

7 Paul M. Norman, SBN 016682
8 Attorneys for Petitioner City of Scottsdale

9
10 **IN THE SUPERIOR COURT OF THE STATE OF ARIZONA**
11 **IN AND FOR THE COUNTY OF MARICOPA**

12 **IN RE THE DETERMINATION OF: THE**
13 **VALIDITY OF AMENDMENT NO. 12 TO THE**
14 **SUBCONTRACT BETWEEN THE UNITED**
15 **STATES, CENTRAL ARIZONA WATER**
16 **CONSERVATION DISTRICT AND THE CITY**
17 **OF SCOTTSDALE; THE VALIDITY OF**
18 **AMENDMENT NO. 1 TO THE**
19 **SUBCONTRACT BETWEEN THE UNITED**
20 **STATES, CENTRAL ARIZONA WATER**
21 **CONSERVATION DISTRICT AND**
22 **CAREFREE WATER COMPANY, INC.; AND**
23 **THE VALIDITY OF THE SUBCONTRACT**
24 **BETWEEN THE UNITED STATES, CENTRAL**
25 **ARIZONA WATER CONSERVATION**
26 **DISTRICT AND TONTO HILLS UTILITY**
COMPANY

NO. CV2001- 021732

JUDGMENT VALIDATING CENTRAL
ARIZONA PROJECT SUBCONTRACTS
AND SUBCONTRACT AMENDMENTS

27 This matter having duly and regularly come on for hearing before this Court on the 22nd
28 day of February, 2002, and the Court having considered the Petition filed herein, and being
29 fully advised in the premises, finds as follows:

30 1. This Court has jurisdiction over this proceeding pursuant to A.R.S. § 48-3731 et
31 seq.

32 2. Petitioners were each organized in compliance with all applicable laws of the
33 State of Arizona.

1 3. The proceedings leading up to the making of Amendment No. 12 to the
 2 Subcontract Among the United States, the Central Arizona Water Conservation District and
 3 the City of Scottsdale, Providing for Water Service, Central Arizona Project (Subcontract No.
 4 5-07-30-W0063) (the "Scottsdale Subcontract"), are valid and in accordance with law.

5 4. The proceedings leading up to the making of Amendment No. 1 to the
 6 Subcontract Among the United States, the Central Arizona Water Conservation District and
 7 the Carefree Water Company, Inc., Providing for Water Service, Central Arizona Project
 8 (Subcontract No. 0-07-30-W0248) (the "Carefree Subcontract"), are valid and in accordance
 9 with law.

10 5. The proceedings leading up to the making of the Subcontract Among the United
 11 States, the Central Arizona Water Conservation District and the Tonto Hills Utility Company,
 12 Providing for Water Service, Central Arizona Project (Subcontract No. 01-XX-30-W0399) (the
 13 "Tonto Hills Subcontract"), are valid and in accordance with law.

14 6. The proceedings in connection with the filing of the Petition in this matter, and
 15 the giving of Notice of Hearing thereon, comply with the provisions of Title 48, Chapter 22,
 16 Article 2, Arizona Revised Statutes, consisting of A.R.S. §§ 48-3731-3734.

17 7. The Scottsdale Subcontract is in substantial compliance with law.

18 8. The Scottsdale Subcontract is valid and binding upon, and enforceable against,
 19 Petitioner City of Scottsdale.

20 9. The Carefree Subcontract is in substantial compliance with law.

21 10. The Carefree Subcontract is valid and binding upon, and enforceable against,
 22 Petitioner Carefree Water Company, Inc.

23 11. The Tonto Hills Subcontract is in substantial compliance with law.

24 12. The Tonto Hills Subcontract is valid and binding upon, and enforceable against,
 25 Petitioner Tonto Hills Utility Company.

26

1 NOW, THEREFORE, IT IS HEREBY ORDERED, ADJUDGED AND DECREED,
2 approving, ratifying, confirming and validating Amendment No. 12 to Subcontract for Central
3 Arizona Project Water, entered into on September 13, 2001, by and among the United States
4 of America, the Central Arizona Water Conservation District and the City of Scottsdale
5 (Subcontract No. 5-07-30-W0063).

6 IT IS HEREBY FURTHER ORDERED, ADJUDGED AND DECREED, approving,
7 ratifying, confirming and validating Amendment No. 1 to Subcontract for Central Arizona
8 Project Water, entered into on July 20, 2001, by and among the United States of America, the
9 Central Arizona Water Conservation District and Carefree Water Company, Inc. (Subcontract
10 No. 0-07-30-W0248).

11 IT IS HEREBY FURTHER ORDERED, ADJUDGED AND DECREED, approving,
12 ratifying, confirming and validating the Subcontract for Central Arizona Project Water, entered
13 into on July 20, 2001, by and among the United States of America, the Central Arizona Water
14 Conservation District and Tonto Hills Utility Company (Subcontract No. 01-XX-30-W0399).

15
16 DONE IN OPEN COURT this 22nd day of February, 2002.

17
18
19 JUDGE CARY A. HARRISON
Judge of the Superior Court

10

SECTION 4-10



INC. ENVIRONMENTAL CONSULTANTS

114 North San Francisco, Suite 100 • Flagstaff, Arizona 86001

CONTRACT

Date 10/29/99 Project Title Tonto Hills Mitigation Project Number _____

Client Contact Person Don Uthank Telephone No. 480-948-5030
Company Name Tonto Hills Utility Co. Fax No. 480-922-9872
Street or P.O. Box 11802 E. Blue Wash Road
City Cave Creek State AZ Zip 85331

Scope of Services that SWCA, Inc. will perform under this contract (use Attachments if necessary):
Conduct archival research, field work, and write a report with results. See the Mitigation
Plan section in the archaeological survey report for further details.

Payment for Professional Services (check one):

- SWCA shall be reimbursed \$ _____ on a Fixed Fee basis.
- SWCA shall be reimbursed on a Time and Materials basis.
- SWCA shall be reimbursed on a Time and Materials basis not-to-exceed (NTE) \$ 27,028.00
 - A rate schedule should be attached for Time and Materials and NTE contracts.
 - Subcontractors to SWCA shall be billed at cost plus 20 percent unless specified in Special Conditions

HAS BEEN REVISED TO 28,528.00

Payment for Other Direct Costs (ODCs) (check one):

- ODCs are included in Professional Services.
- There is a separate NTE/Fixed Fee of \$ _____ for ODCs.
- ODCs shall be billed at cost plus 15 percent unless specified in Special Conditions.

Retainer: A retainer of \$ _____ must be received by (date) _____

Special Conditions: Please return signed contract to:
SWCA Inc.
100 West Coolidge Street
Phoenix, AZ 85013

This Agreement shall be considered a Notice to Proceed when signed by both parties.

SWCA, Inc., Environmental Consultants
Accepted by: _____
Signature: _____
Title: _____
Date: _____

Client: TONTO HILLS UTILITY COMPANY
Accepted by: DONALD J. UTHANK, PRES.
Signature: [Signature]
Title: PRES.
Date: 11-10-99

The Terms and Conditions on the reverse of this form are a part of this Agreement

SWCA, Inc., Environmental Consultants • 114 N. San Francisco Street, Suite 100 • Flagstaff, Arizona 86001
Telephone (520) 774-5500 • Fax (520) 779-2709 • Tax I.D. Number 860483317

Original to SWCA, Inc. Contract File; Pink Copy to Client; Yellow Copy to Project Manager

Corporate Office:
2120 N. Central Ave. Suite 130 Phoenix, AZ 85004
Tel: (602)274-3831 Acctg Fax: (602)274-3958

SWCASM

ENVIRONMENTAL CONSULTANTS

Remit To: P.O. Box 92170
Elk Grove, IL 60009

Invoice Number: 12734

January 18, 2002

To: Tonto Hills Utility Company
11802 E. Blue Wash Road

Cave Creek, AZ 85331

Attention: Mr. Don Unthank

Contract Maximum: \$28,528.00

Previous Billings Against Maximum: \$28,360.75

Current Billings Against Maximum: \$167.25

Balance After This Invoice: \$0.00

Project: 3640-3331 Period: 9/9/01 to 1/12/02

Tonto Hills Mitigation

Billing Group: 1-33 Phoenix Cultural Resources
Billing Group Manager: North, Chris

Billing Group Maximum: \$27,028.00
Previous Billings Against Maximum: \$26,860.75
Current Billings Against Maximum: \$167.25
Billing Group Balance: \$0.00

Professional Fees:

Kohler, Kelle Word Processor
Total Professional Fees

<u>Bill Hours</u>	<u>Bill Rate</u>	<u>Charge</u>
1.50	\$36.00	\$54.00
		<hr/> \$54.00

Direct Expenses:

Curation
Total Direct Expenses

\$255.88

\$255.88

Billing Group 1-33 Subtotals

~~\$309.88~~

**Water Infrastructure Finance Authority Requisition 1, Page 3 of 3
 MBE/WBE/SBRA Report
 Tonto Hills Utility Company**

Contractor/Subcontractor/Vendor Name & Address	Product / Service Type (See code #'s Below)	MBE ✓	WBE ✓	SBRA ✓	\$ Amount
S.W.C.A. ENVIRONMENTAL CONSULTANTS P.O. BOX 1388 FLAGSTAFF AZ 86002	9-B				1,785.58
(S Amt must equal the total from pg. 2, Line 7g, column 2: "This Request")				Total Disbursed \$	

Type of Product or Service Codes:

- 3 = Construction
- 4 = Manufacturing
- 5 = Transportation

- 6 = Supplies & Equipment, Wholesale
- 7 = Supplies & Equipment, Retail
- 10 = Other

9 = Services

- 9a = Business Services
- 9b = Professional Services
- 9c = Other
- 9d = Professional Services

- A. Reporting Requirements: Report on any *procurement* that is actually executed.
 - B. Procurement: is the acquisition through order, purchase, lease or barter of supplies, equipment, construction, or services.
 - C. Minority Business Enterprise (MBE): is a business concern that is (1) at least 51 percent owned by one or more minority individuals, or in the case of a publicly owned business, at least 51 percent owned by one or more minority individuals; and (2) whose daily business operations are managed and directed by one or more of the minority owners.*
 - D. Women Business Enterprise (WBE): is a business concern that is (1) at least 51 percent owned by one or more women, or, in the case of a publicly owned business, at least 51 percent of the stock is owned by one or more women; and (2) whose daily business operations are managed and directed by one or more of the women owners.*
- * (Business firms which are 51 percent owned by minorities or women, but are in fact managed and operated by individuals who are not minorities or women; do not qualify for meeting MBE/WBE goals.)
- E. Small Business Enterprise in a Rural Area (SBRA): is a business concern that is physically located outside any standard metropolitan statistical area.

Water Infrastructure Finance Authority Requisition 2, Page 3 of 3
MBE/WBE/SBRA Report
Tonto Hills Utility Company

Contractor/Subcontractor/Vendor Name & Address	Product / Service Type (See code #'s Below)	MBE ✓	WBE ✓	SBRA ✓	\$ Amount
S.W., C. A ENVIRONMENTAL CONSULTANTS					267,27
PO Box 1888, FLAGSTAFF AZ 86002	9-B				267,27
(\$Amt must equal the total from pg. 2, Line 7g, column 2: "This Request")				Total Disbursed \$	267,27

Type of Product or Service Codes:

- 3 = Construction
- 4 = Manufacturing
- 5 = Transportation
- 6 = Supplies & Equipment, Wholesale
- 7 = Supplies & Equipment, Retail
- 10 = Other

9 = Services

- 9a = Business Services
- 9b = Professional Services
- 9c = Other
- 9d = Professional Services

- A. Reporting Requirements: Report on any procurement that is actually executed.
- B. Procurement: is the acquisition through order, purchase, lease or barter of supplies, equipment, construction, or services.
- C. Minority Business Enterprise (MBE): is a business concern that is (1) at least 51 percent owned by one or more minority individuals, or in the case of a publicly owned business, at least 51 percent owned by one or more minority individuals; and (2) whose daily business operations are managed and directed by one or more of the minority owners.*
- D. Women Business Enterprise (WBE): is a business concern that is (1) at least 51 percent owned by one or more women, or, in the case of a publicly owned business, at least 51 percent of the stock is owned by one or more women; and (2) whose daily business operations are managed and directed by one or more of the women owners.*
- * (Business firms which are 51 percent owned by minorities or women, but are in fact managed and operated by individuals who are not minorities or women; do not qualify for meeting MBE/WBE goals.)
- E. Small Business Enterprise in a Rural Area (SBRA): is a business concern that is physically located outside any standard metropolitan statistical area.

Water Infrastructure Finance Authority Requisition 3, Page 3 of 3
MBE/WBE/SBRA Report
Tonto Hills Utility Company

Contractor/Subcontractor/Vendor Name & Address	Product / Service Type (See code #'s Below)	MBE ✓	WBE ✓	SBRA ✓	\$ Amount
S.W.C.A., INC. ENVIRONMENTAL CONSULTANTS PO BOX 1888 FLAGSTAFF, AZ 86002 9-B					1670.00
(\$Amt must equal the total from pg. 2, Line 7g, column 2: "This Request")					Total Disbursed \$ 1670.00

Type of Product or Service Codes:

- 3 = Construction
- 4 = Manufacturing
- 5 = Transportation
- 6 = Supplies & Equipment, Wholesale
- 7 = Supplies & Equipment, Retail
- 10 = Other

9 = Services

- 9a = Business Services
- 9b = Professional Services
- 9c = Other
- 9d = Professional Services

A. Reporting Requirements: Report on any *procurement* that is actually executed.

B. Procurement: is the acquisition through order, purchase, lease or barter of supplies, equipment, construction, or services.

C. Minority Business Enterprise (MBE): is a business concern that is (1) at least 51 percent owned by one or more minority individuals, or in the case of a publicly owned business, at least 51 percent owned by one or more minority individuals; and (2) whose daily business operations are managed and directed by one or more of the minority owners.*

D. Women Business Enterprise (WBE): is a business concern that is (1) at least 51 percent owned by one or more women, or, in the case of a publicly owned business, at least 51 percent of the stock is owned by one or more women; and (2) whose daily business operations are managed and directed by one or more of the women owners.*

* (Business firms which are 51 percent owned by minorities or women, but are in fact managed and operated by individuals who are not minorities or women; do not qualify for meeting MBE/WBE goals.)

E. Small Business Enterprise in a Rural Area (SBRA): is a business concern that is physically located outside any standard metropolitan statistical area.

Water Infrastructure Finance Authority Requisition 4, Page 3 of 3
MBE/WBE/SBRA Report
Tonto Hills Utility Company

Contractor/Subcontractor/Vendor Name & Address	Product / Service Type (See code #'s Below)	MBE ✓	WBE ✓	SBRA ✓	\$ Amount
BUREAU OF RECLAMATION FILE # 91547 PO BOX 6000	9-B				2500.00
SAN FRANCISCO, CA 94160-1547					
(\$ Amt must equal the total from pg. 2, Line 7g, column 2: "This Request")				Total Disbursed \$	2500.00

Type of Product or Service Codes:

- 3 = Construction
- 4 = Manufacturing
- 5 = Transportation
- 6 = Supplies & Equipment, Wholesale
- 7 = Supplies & Equipment, Retail
- 10 = Other

9 = Services

- 9a = Business Services
- 9b = Professional Services
- 9c = Other
- 9d = Professional Services

A. Reporting Requirements: Report on any *procurement* that is actually executed.

B. Procurement: is the acquisition through order, purchase, lease or barter of supplies, equipment, construction, or services.

C. Minority Business Enterprise (MBE): is a business concern that is (1) at least 51 percent owned by one or more minority individuals, or in the case of a publicly owned business, at least 51 percent owned by one or more minority individuals; and (2) whose daily business operations are managed and directed by one or more of the minority owners.*

D. Women Business Enterprise (WBE): is a business concern that is (1) at least 51 percent owned by one or more women, or, in the case of a publicly owned business, at least 51 percent of the stock is owned by one or more women; and (2) whose daily business operations are managed and directed by one or more of the women owners.*

* (Business firms which are 51 percent owned by minorities or women, but are in fact managed and operated by individuals who are not minorities or women; do not qualify for meeting MBE/WBE goals.)

E. Small Business Enterprise in a Rural Area (SBRA): is a business concern that is physically located outside any standard metropolitan statistical area.

**Water Infrastructure Finance Authority Requisition 5, Page 3 of 3
 MBE/WBE/SBRA Report
 Tonto Hills Utility Company**

Contractor/Subcontractor/Vendor Name & Address	Product / Service Type (See code #'s Below)	MBE ✓	WBE ✓	SBRA ✓	\$ Amount
S.W., C.A. ENVIRONMENTAL CONSULTANTS	9-B				360,29
(\$Amt must equal the total from pg. 2, Line 7g, column 2: "This Request")				Total Disbursed \$	

Type of Product or Service Codes:

- 3 = Construction
- 4 = Manufacturing
- 5 = Transportation

- 6 = Supplies & Equipment, Wholesale
- 7 = Supplies & Equipment, Retail
- 10 = Other

9 = Services

- 9a = Business Services
- 9b = Professional Services
- 9c = Other
- 9d = Professional Services

- A. Reporting Requirements: Report on any procurement that is actually executed.
- B. Procurement: is the acquisition through order, purchase, lease or barter of supplies, equipment, construction, or services.
- C. Minority Business Enterprise (MBE): is a business concern that is (1) at least 51 percent owned by one or more minority individuals, or in the case of a publicly owned business, at least 51 percent owned by one or more minority individuals; and (2) whose daily business operations are managed and directed by one or more of the minority owners.*
- D. Women Business Enterprise (WBE): is a business concern that is (1) at least 51 percent owned by one or more women, or, in the case of a publicly owned business, at least 51 percent of the stock is owned by one or more women; and (2) whose daily business operations are managed and directed by one or more of the women owners.*
- * (Business firms which are 51 percent owned by minorities or women, but are in fact managed and operated by individuals who are not minorities or women; do not qualify for meeting MBE/WBE goals.)
- E. Small Business Enterprise in a Rural Area (SBRA): is a business concern that is physically located outside any standard metropolitan statistical area.

**Water Infrastructure Finance Authority Requisition 6, Page 3 of 3
 MBE/WBE/SBRA Report
 Tonto Hills Utility Company**

Contractor/Subcontractor/Vendor Name & Address	Product / Service Type (See code #'s Below)	MBE ✓	WBE ✓	SBRA ✓	\$ Amount
S.W.C.A. ENVIRONMENTAL CONSULTANTS	9-B				265,950
(\$Amt must equal the total from pg. 2, Line 7g, column 2: "This Request")				Total Disbursed \$	

Type of Product or Service Codes:

- 3 = Construction
- 4 = Manufacturing
- 5 = Transportation
- 6 = Supplies & Equipment, Wholesale
- 7 = Supplies & Equipment, Retail
- 10 = Other

9 = Services

- 9a = Business Services
- 9b = Professional Services
- 9c = Other
- 9d = Professional Services

A. Reporting Requirements: Report on any *procurement* that is actually executed.

B. Procurement: is the acquisition through order, purchase, lease or barter of supplies, equipment, construction, or services.

C. Minority Business Enterprise (MBE): is a business concern that is (1) at least 51 percent owned by one or more minority individuals, or in the case of a publicly owned business, at least 51 percent owned by one or more minority individuals; and (2) whose daily business operations are managed and directed by one or more of the minority owners.*

D. Women Business Enterprise (WBE): is a business concern that is (1) at least 51 percent owned by one or more women, or, in the case of a publicly owned business, at least 51 percent of the stock is owned by one or more women; and (2) whose daily business operations are managed and directed by one or more of the women owners.*

* (Business firms which are 51 percent owned by minorities or women, but are in fact managed and operated by individuals who are not minorities or women; do not qualify for meeting MBE/WBE goals.)

E. Small Business Enterprise in a Rural Area (SBRA): is a business concern that is physically located outside any standard metropolitan statistical area.

Water Infrastructure Finance Authority Requisition 7, Page 3 of 3
MBE/WBE/SBRA Report
Tonto Hills Utility Company

Contractor/Subcontractor/Vendor Name & Address	Product / Service Type (See code #'s Below)	MBE ✓	WBE ✓	SBRA ✓	\$ Amount
S.W.C.A. ENVIRONMENTAL CONSULTANTS	9-B				695,36
(\$Amt must equal the total from pg. 2, Line 7g, column 2: "This Request") Total Disbursed \$					

Type of Product or Service Codes:

- 3 = Construction
- 4 = Manufacturing
- 5 = Transportation

- 6 = Supplies & Equipment, Wholesale
- 7 = Supplies & Equipment, Retail
- 10 = Other

9 = Services

- 9a = Business Services
- 9b = Professional Services
- 9c = Other
- 9d = Professional Services

- A. Reporting Requirements:** Report on any *procurement* that is actually executed.
- B. Procurement:** is the acquisition through order, purchase, lease or barter of supplies, equipment, construction, or services.
- C. Minority Business Enterprise (MBE):** is a business concern that is (1) at least 51 percent owned by one or more minority individuals, or in the case of a publicly owned business, at least 51 percent owned by one or more minority individuals; and (2) whose daily business operations are managed and directed by one or more of the minority owners.*
- D. Women Business Enterprise (WBE):** is a business concern that is (1) at least 51 percent owned by one or more women, or, in the case of a publicly owned business, at least 51 percent of the stock is owned by one or more women; and (2) whose daily business operations are managed and directed by one or more of the women owners.*
- * (Business firms which are 51 percent owned by minorities or women, but are in fact managed and operated by individuals who are not minorities or women; do not qualify for meeting MBE/WBE goals.)
- E. Small Business Enterprise in a Rural Area (SBRA):** is a business concern that is physically located outside any standard metropolitan statistical area.

**Water Infrastructure Finance Authority Requisition 8, Page 3 of 3
 MBE/WBE/SBRA Report
 Tonto Hills Utility Company**

Contractor/Subcontractor/Vendor Name & Address	Product / Service Type (See code #'s Below)	MBE ✓	WBE ✓	SBRA ✓	\$ Amount
S.W.C.A. ENVIRONMENTAL CONSULTANTS	9-B				340,23
(\$Amt must equal the total from pg. 2, Line 7g, column 2: "This Request")					Total Disbursed \$

Type of Product or Service Codes:

- 3 = Construction
- 4 = Manufacturing
- 5 = Transportation

- 6 = Supplies & Equipment, Wholesale
- 7 = Supplies & Equipment, Retail
- 10 = Other

9 = Services

- 9a = Business Services
- 9b = Professional Services
- 9c = Other
- 9d = Professional Services

- A. Reporting Requirements: Report on any *procurement* that is actually executed.
 - B. Procurement: is the acquisition through order, purchase, lease or barter of supplies, equipment, construction, or services.
 - C. Minority Business Enterprise (MBE): is a business concern that is (1) at least 51 percent owned by one or more minority individuals, or in the case of a publicly owned business, at least 51 percent owned by one or more minority individuals; and (2) whose daily business operations are managed and directed by one or more of the minority owners.*
 - D. Women Business Enterprise (WBE): is a business concern that is (1) at least 51 percent owned by one or more women, or, in the case of a publicly owned business, at least 51 percent of the stock is owned by one or more women; and (2) whose daily business operations are managed and directed by one or more of the women owners.*
- * (Business firms which are 51 percent owned by minorities or women, but are in fact managed and operated by individuals who are not minorities or women; do not qualify for meeting MBE/WBE goals.)
- E. Small Business Enterprise in a Rural Area (SBRA): is a business concern that is physically located outside any standard metropolitan statistical area.



REQ 9

**Water Infrastructure Finance Authority Requisition 9, Page 3 of 3
 MBE/WBE/SBRA Report
 Tonto Hills Utility Company**

Contractor/Subcontractor/Vendor Name & Address	Product / Service Type (See code #'s Below)	MBE ✓	WBE ✓	SBRA ✓	\$ Amount
S.W.C.A. ENVIRONMENTAL CONSULTANTS	9-B				2,745.19
(\$Amt must equal the total from pg. 2, Line 7g, column 2: "This Request")				Total Disbursed \$	

Type of Product or Service Codes:

- 3 = Construction
- 4 = Manufacturing
- 5 = Transportation

- 6 = Supplies & Equipment, Wholesale
- 7 = Supplies & Equipment, Retail
- 10 = Other

9 = Services

- 9a = Business Services
- 9b = Professional Services
- 9c = Other
- 9d = Professional Services

- A. Reporting Requirements: Report on any *procurement* that is actually executed.
 - B. Procurement: is the acquisition through order, purchase, lease or barter of supplies, equipment, construction, or services.
 - C. Minority Business Enterprise (MBE): is a business concern that is (1) at least 51 percent owned by one or more minority individuals, or in the case of a publicly owned business, at least 51 percent owned by one or more minority individuals; and (2) whose daily business operations are managed and directed by one or more of the minority owners.*
 - D. Women Business Enterprise (WBE): is a business concern that is (1) at least 51 percent owned by one or more women, or, in the case of a publicly owned business, at least 51 percent of the stock is owned by one or more women; and (2) whose daily business operations are managed and directed by one or more of the women owners.*
- *(Business firms which are 51 percent owned by minorities or women, but are in fact managed and operated by individuals who are not minorities or women; do not qualify for meeting MBE/WBE goals.)
- E. Small Business Enterprise in a Rural Area (SBRA): is a business concern that is physically located outside any standard metropolitan statistical area.

**Water Infrastructure Finance Authority Requisition 10, Page 3 of 3
MBE/WBE/SBRA Report
Tonto Hills Utility Company**

Contractor/Subcontractor/Vendor Name & Address	Product / Service Type (See code #'s Below)	MBE ✓	WBE ✓	SBRA ✓	\$ Amount
S.W.C. A. ENVIRONMENTAL CONSULTANTS	9-B				6,595.96
NEW REMITTANCE ADDRESS					
↓ P.O. BOX 92170 ELK GROVE, IL, 60009					
(\$Amt must equal the total from pg. 2, Line 7g, column 2: "This Request")					Total Disbursed \$

Type of Product or Service Codes:

- 3 = Construction
- 4 = Manufacturing
- 5 = Transportation

- 6 = Supplies & Equipment, Wholesale
- 7 = Supplies & Equipment, Retail
- 10 = Other

9 = Services

- 9a = Business Services
- 9b = Professional Services
- 9c = Other
- 9d = Professional Services

A. Reporting Requirements: Report on any *procurement* that is actually executed.

B. Procurement: is the acquisition through order, purchase, lease or barter of supplies, equipment, construction, or services.

C. Minority Business Enterprise (MBE): is a business concern that is (1) at least 51 percent owned by one or more minority individuals, or in the case of a publicly owned business, at least 51 percent owned by one or more minority individuals; and (2) whose daily business operations are managed and directed by one or more of the minority owners.*

D. Women Business Enterprise (WBE): is a business concern that is (1) at least 51 percent owned by one or more women, or, in the case of a publicly owned business, at least 51 percent of the stock is owned by one or more women; and (2) whose daily business operations are managed and directed by one or more of the women owners.*

*(Business firms which are 51 percent owned by minorities or women, but are in fact managed and operated by individuals who are not minorities or women; do not qualify for meeting MBE/WBE goals.)

E. Small Business Enterprise in a Rural Area (SBRA): is a business concern that is physically located outside any standard metropolitan statistical area.

Water Infrastructure Finance Authority Requisition 11, Page 3 of 3
MBE/WBE/SBRA Report
Tonto Hills Utility Company

Contractor/Subcontractor/Vendor Name & Address	Product / Service Type (See code #'s Below)	MBE ✓	WBE ✓	SBRA ✓	\$ Amount
S.W.C.A. ENVIRONMENTAL CONSULTANTS	9-B				4,697.93
NEW REMITTANCE ADDRESS					
PO Box 92170 ELK GROVE, IL, 60009					
(\$Amt must equal the total from pg. 2, Line 7g, column 2: "This Request")					Total Disbursed \$

Type of Product or Service Codes:

- 3 = Construction
- 4 = Manufacturing
- 5 = Transportation

- 6 = Supplies & Equipment, Wholesale
- 7 = Supplies & Equipment, Retail
- 10 = Other

9 = Services

- 9a = Business Services
- 9b = Professional Services
- 9c = Other
- 9d = Professional Services

- A. Reporting Requirements: Report on any *procurement* that is actually executed.
- B. Procurement: is the acquisition through order, purchase, lease or barter of supplies, equipment, construction, or services.
- C. Minority Business Enterprise (MBE): is a business concern that is (1) at least 51 percent owned by one or more minority individuals, or in the case of a publicly owned business, at least 51 percent owned by one or more minority individuals; and (2) whose daily business operations are managed and directed by one or more of the minority owners.*
- D. Women Business Enterprise (WBE): is a business concern that is (1) at least 51 percent owned by one or more women, or, in the case of a publicly owned business, at least 51 percent of the stock is owned by one or more women; and (2) whose daily business operations are managed and directed by one or more of the women owners.*
- * (Business firms which are 51 percent owned by minorities or women, but are in fact managed and operated by individuals who are not minorities or women; do not qualify for meeting MBE/WBE goals.)
- E. Small Business Enterprise in a Rural Area (SBRA): is a business concern that is physically located outside any standard metropolitan statistical area.

**Water Infrastructure Finance Authority Requisition 12, Page 3 of 3
MBE/WBE/SBRA Report
Tonto Hills Utility Company**

Contractor/Subcontractor/Vendor Name & Address	Product / Service Type (See code #'s Below)	MBE ✓	WBE ✓	SBRA ✓	\$ Amount
SWCA ENVIRONMENTAL CONSULTANTS	9-B				1,898 ¹⁸
NEW REMITTANCE ADDRESS					
↓					
P.O. Box 92170					
BELK GROVE, IL., 60009					
(SAmnt must equal the total from pg. 2, Line 7g, column 2: "This Request")				Total Disbursed \$	

Type of Product or Service Codes:

- 3 = Construction
- 4 = Manufacturing
- 5 = Transportation

- 6 = Supplies & Equipment, Wholesale
- 7 = Supplies & Equipment, Retail
- 10 = Other

9 = Services

- 9a = Business Services
- 9b = Professional Services
- 9c = Other
- 9d = Professional Services

A. Reporting Requirements: Report on any procurement that is actually executed.

B. Procurement: is the acquisition through order, purchase, lease or barter of supplies, equipment, construction, or services.

C. Minority Business Enterprise (MBE): is a business concern that is (1) at least 51 percent owned by one or more minority individuals, or in the case of a publicly owned business, at least 51 percent owned by one or more minority individuals; and (2) whose daily business operations are managed and directed by one or more of the minority owners.*

D. Women Business Enterprise (WBE): is a business concern that is (1) at least 51 percent owned by one or more women, or, in the case of a publicly owned business, at least 51 percent of the stock is owned by one or more women; and (2) whose daily business operations are managed and directed by one or more of the women owners.*

*(Business firms which are 51 percent owned by minorities or women, but are in fact managed and operated by individuals who are not minorities or women; do not qualify for meeting MBE/WBE goals.)

E. Small Business Enterprise in a Rural Area (SBRA): is a business concern that is physically located outside any standard metropolitan statistical area.

Water Infrastructure Finance Authority Requisition 13, Page 3 of 3
MBE/WBE/SBRA Report
Tonto Hills Utility Company

Contractor/Subcontractor/Vendor Name & Address	Product / Service Type (See code #'s Below)	MBE ✓	WBE ✓	SBRA ✓	\$ Amount
S.W.C.A. ENVIRONMENTAL CONSULTANTS					2,252 ⁵⁰
NEW REMITTANCE ADDRESS					
↓					
P.O. Box 9270					
ECK GROVE, IL 60009					
(\$Amt must equal the total from pg. 2, Line 7g, column 2: "This Request")					Total Disbursed \$

Type of Product or Service Codes:

- 3 = Construction
- 4 = Manufacturing
- 5 = Transportation

- 6 = Supplies & Equipment, Wholesale
- 7 = Supplies & Equipment, Retail
- 10 = Other

9 = Services

- 9a = Business Services
- 9h = Professional Services
- 9c = Other
- 9d = Professional Services

A. Reporting Requirements: Report on any *procurement* that is actually executed.

B. Procurement: is the acquisition through order, purchase, lease or barter of supplies, equipment, construction, or services.

C. Minority Business Enterprise (MBE): is a business concern that is (1) at least 51 percent owned by one or more minority individuals, or in the case of a publicly owned business, at least 51 percent owned by one or more minority individuals; and (2) whose daily business operations are managed and directed by one or more of the minority owners.*

D. Women Business Enterprise (WBE): is a business concern that is (1) at least 51 percent owned by one or more women, or, in the case of a publicly owned business, at least 51 percent of the stock is owned by one or more women; and (2) whose daily business operations are managed and directed by one or more of the women owners.*

*(Business firms which are 51 percent owned by minorities or women, but are in fact managed and operated by individuals who are not minorities or women; do not qualify for meeting MBE/WBE goals.)

E. Small Business Enterprise in a Rural Area (SBRA): is a business concern that is physically located outside any standard metropolitan statistical area.

**Water Infrastructure Finance Authority Requisition 14, Page 3 of 3
 MBE/WBE/SBRA Report
 Tonto Hills Utility Company**

Contractor/Subcontractor/Vendor Name & Address	Product / Service Type (See code #'s Below)	MBE ✓	WBE ✓	SBRA ✓	\$ Amount
S.W.C.A - ENVIRONMENTAL CONSULTANTS					2397.76
PO BOX 92170 ELK GROVE, IL 60009					
(\$Amt must equal the total from pg. 2, Line 7g, column 2: "This Request") Total Disbursed \$					

Type of Product or Service Codes:

- 3 = Construction
- 4 = Manufacturing
- 5 = Transportation

- 6 = Supplies & Equipment, Wholesale
- 7 = Supplies & Equipment, Retail
- 10 = Other

9 = Services

- 9a = Business Services
- 9b = Professional Services
- 9c = Other
- 9d = Professional Services

- A. Reporting Requirements: Report on any procurement that is actually executed.
 - B. Procurement: Is the acquisition through order, purchase, lease or barter of supplies, equipment, construction, or services.
 - C. Minority Business Enterprise (MBE): is a business concern that is (1) at least 51 percent owned by one or more minority individuals, or in the case of a publicly owned business, at least 51 percent owned by one or more minority individuals; and (2) whose daily business operations are managed and directed by one or more of the minority owners.*
 - D. Women Business Enterprise (WBE): is a business concern that is (1) at least 51 percent owned by one or more women, or, in the case of a publicly owned business, at least 51 percent of the stock is owned by one or more women; and (2) whose daily business operations are managed and directed by one or more of the women owners.*
- * (Business firms which are 51 percent owned by minorities or women, but are in fact managed and operated by individuals who are not minorities or women; do not qualify for meeting MBE/WBE goals.)
- E. Small Business Enterprise in a Rural Area (SBRA): is a business concern that is physically located outside any standard metropolitan statistical area.

**Water Infrastructure Finance Authority Requisition 15, Page 3 of 3
 MBE/WBE/SBRA Report
 Tonto Hills Utility Company**

Contractor/Subcontractor/Vendor Name & Address	Product / Service Type (See code #'s Below)	MBE ✓	WBE ✓	SBRA ✓	\$ Amount
CENTRAL ARIZONA PROJECT PO. BOX. 42117					1526 ⁵⁰
PHOENIX, AZ 85030 2117					
(\$Amt must equal the total from pg. 2, Line 7g, column 2: "This Request") Total Disbursed \$					

- Type of Product or Service Codes:**
- | | | |
|--------------------|-------------------------------------|----------------------------|
| 3 = Construction | 6 = Supplies & Equipment. Wholesale | 9 = Services |
| 4 = Manufacturing | 7 = Supplies & Equipment. Retail | 9a = Business Services |
| 5 = Transportation | 10 = Other | 9b = Professional Services |
| | | 9c = Other |
| | | 9d = Professional Services |

A. Reporting Requirements: Report on any procurement that is actually executed.
 B. Procurement: is the acquisition through order, purchase, lease or barter of supplies, equipment, construction, or services.
 C. Minority Business Enterprise (MBE): is a business concern that is (1) at least 51 percent owned by one or more minority individuals, or in the case of a publicly owned business, at least 51 percent owned by one or more minority individuals; and (2) whose daily business operations are managed and directed by one or more of the minority owners.*
 D. Women Business Enterprise (WBE): is a business concern that is (1) at least 51 percent owned by one or more women, or, in the case of a publicly owned business, at least 51 percent of the stock is owned by one or more women; and (2) whose daily business operations are managed and directed by one or more of the women owners.*
 *(Business firms which are 51 percent owned by minorities or women, but are in fact managed and operated by individuals who are not minorities or women; do not qualify for meeting MBE/WBE goals.)
 E. Small Business Enterprise in a Rural Area (SBRA): is a business concern that is physically located outside any standard metropolitan statistical area.

Water Infrastructure Finance Authority Requisition 16, Page 3 of 3
MBE/WBE/SBRA Report
Tonto Hills Utility Company

Contractor/Subcontractor/Vendor Name & Address	Product / Service Type (See code #'s Below)	MBE ✓	WBE ✓	SBRA ✓	\$ Amount
S.W.C.A. ENVIRONMENTAL CONSULTANTS					167.25
P.O. BOX 92170 ECK GROVE, IL., 60009					
(\$Amt must equal the total from pg. 2, Line 7g, column 2: "This Request")					Total Disbursed \$

Type of Product or Service Codes:

- 3 = Construction
- 4 = Manufacturing
- 5 = Transportation

- 6 = Supplies & Equipment, Wholesale
- 7 = Supplies & Equipment, Retail
- 10 = Other

9 = Services

- 9a = Business Services
- 9b = Professional Services
- 9c = Other
- 9d = Professional Services

- A. Reporting Requirements: Report on any *procurement* that is actually executed.
 - B. Procurement: is the acquisition through order, purchase, lease or barter of supplies, equipment, construction, or services.
 - C. Minority Business Enterprise (MBE): is a business concern that is (1) at least 51 percent owned by one or more minority individuals, or in the case of a publicly owned business, at least 51 percent owned by one or more minority individuals; and (2) whose daily business operations are managed and directed by one or more of the minority owners.*
 - D. Women Business Enterprise (WBE): is a business concern that is (1) at least 51 percent owned by one or more women, or, in the case of a publicly owned business, at least 51 percent of the stock is owned by one or more women; and (2) whose daily business operations are managed and directed by one or more of the women owners.*
- * (Business firms which are 51 percent owned by minorities or women, but are in fact managed and operated by individuals who are not minorities or women; do not qualify for meeting MBE/WBE goals.)
- E. Small Business Enterprise in a Rural Area (SBRA): is a business concern that is physically located outside any standard metropolitan statistical area.

**Water Infrastructure Finance Authority Requisition 17, Page 3 of 3
 MBE/WBE/SBRA Report
 Tonto Hills Utility Company**

Contractor/Subcontractor/Vendor Name & Address	Product / Service Type (See code #'s Below)	MBE ✓	WBE ✓	SBRA ✓	\$ Amount
CAW, CD.					25,985.14
PO BOX 43020 PHOENIX, AZ, 85080-3020					
28636 N. 7TH ST. PHOENIX AZ 85024					
(\$Amt must equal the total from pg. 2, Line 7g, column 2: "This Request")					Total Disbursed \$

OR

Type of Product or Service Codes:

- 3 = Construction
- 4 = Manufacturing
- 5 = Transportation

- 6 = Supplies & Equipment, Wholesale
- 7 = Supplies & Equipment, Retail
- 10 = Other

9 - Services

- 9a = Business Services
- 9b = Professional Services
- 9c = Other
- 9d = Professional Services

- A. Reporting Requirements: Report on any procurement that is actually executed.
 - B. Procurement: is the acquisition through order, purchase, lease or barter of supplies, equipment, construction, or services.
 - C. Minority Business Enterprise (MBE): is a business concern that is (1) at least 51 percent owned by one or more minority individuals, or in the case of a publicly owned business, at least 51 percent owned by one or more minority individuals; and (2) whose daily business operations are managed and directed by one or more of the minority owners.*
 - D. Women Business Enterprise (WBE): is a business concern that is (1) at least 51 percent owned by one or more women, or, in the case of a publicly owned business, at least 51 percent of the stock is owned by one or more women; and (2) whose daily business operations are managed and directed by one or more of the women owners.*
- * (Business firms which are 51 percent owned by minorities or women, but are in fact managed and operated by individuals who are not minorities or women; do not qualify for meeting MBE/WBE goals.)
- E. Small Business Enterprise in a Rural Area (SBRA): is a business concern that is physically located outside any standard metropolitan statistical area.

**Water Infrastructure Finance Authority Requisition 18, Page 3 of 3
MBE/WBE/SBRA Report
Tonto Hills Utility Company**

Contractor/Subcontractor/Vendor Name & Address	Product / Service Type (See code #'s Below)	MBE ✓	WBE ✓	SBRA ✓	\$ Amount
SOUTHWEST COMMUNITY RESOURCES					7,100 ⁰⁰
8711 E PINNACLE PEAK RD SUITE D-100 SCOTTSDALE	96				
AZ 85255-3555					
(S Amt must equal the total from pg. 2, Line 7g, column 2: "This Request")					Total Disbursed \$

Type of Product or Service Codes:

- 3 = Construction
- 4 = Manufacturing
- 5 = Transportation

- 6 = Supplies & Equipment, Wholesale
- 7 = Supplies & Equipment, Retail
- 10 = Other

9 = Services

- 9a = Business Services
- 9b = Professional Services
- 9c = Other
- 9d = Professional Services

- A. Reporting Requirements: Report on any procurement that is actually executed.
- B. Procurement: is the acquisition through order, purchase, lease or charter of supplies, equipment, construction, or services.
- C. Minority Business Enterprise (MBE): is a business concern that is (1) at least 51 percent owned by one or more minority individuals, or in the case of a publicly owned business, at least 51 percent owned by one or more minority individuals; and (2) whose daily business operations are managed and directed by one or more of the minority owners.*
- D. Women Business Enterprise (WBE): is a business concern that is (1) at least 51 percent owned by one or more women, or, in the case of a publicly owned business, at least 51 percent of the stock is owned by one or more women; and (2) whose daily business operations are managed and directed by one or more of the women owners.*
- *Business firms which are 51 percent owned by minorities or women, but are in fact managed and operated by individuals who are not minorities or women; do not qualify for meeting MBE/WBE goals.
- E. Small Business Enterprise in a Rural Area (SBRA): is a business concern that is physically located outside any standard metropolitan statistical area.

**Water Infrastructure Finance Authority Requisition 19, Page 3 of 3
 MBE/WBE/SBRA Report
 Tonto Hills Utility Company**

Contractor/Subcontractor/Vendor Name & Address	Product / Service Type (See code #'s Below)	MBE ✓	WBE ✓	SBRA ✓	\$ Amount
WATER RESOURCES DEPT. CITY OF SCOTTSDALE					180,640.11
SCOTTSDALE, AZ, 85258					
(Amt must equal the total from pg. 2, Line 7g, column 2: "This Request")				Total Disbursed \$	

- Type of Product or Service Codes:**
- | | | |
|--------------------|-------------------------------------|----------------------------|
| 3 = Construction | 6 = Supplies & Equipment, Wholesale | 9 = Services |
| 4 = Manufacturing | 7 = Supplies & Equipment, Retail | 9a = Business Services |
| 5 = Transportation | 10 = Other | 9b = Professional Services |
| | | 9c = Other |
| | | 9d = Professional Services |

A. Reporting Requirements: Report on any procurement that is actually executed.

B. Procurement: is the acquisition through order, purchase, lease or barter of supplies, equipment, construction, or services.

C. Minority Business Enterprise (MBE): is a business concern that is (1) at least 51 percent owned by one or more minority individuals, or in the case of a publicly owned business, at least 51 percent owned by one or more minority individuals; and (2) whose daily business operations are managed and directed by one or more of the minority owners.*

D. Women Business Enterprise (WBE): is a business concern that is (1) at least 51 percent owned by one or more women, or, in the case of a publicly owned business, at least 51 percent of the stock is owned by one or more women; and (2) whose daily business operations are managed and directed by one or more of the women owners.*

*(Business firms which are 51 percent owned by minorities or women, but are in fact managed and operated by individuals who are not minorities or women: do not qualify for meeting MBE/WBE goals.)

E. Small Business Enterprise in a Rural Area (SBRA): is a business concern that is physically located outside any standard metropolitan statistical area.

Water Infrastructure Finance Authority Requisition 20, Page 3 of 3
 MBE/WBE/SBRA Report
 Tonto Hills Utility Company

Contractor/Subcontractor/Vendor Name & Address	Product / Service Type (See code #'s Below)	MBE	WBE	SBRA	\$ Amount
ESCROW FUND, TONTO HILLS UTILITY CO. AND DISBURS		✓	✓	✓	39,559
MOUNTAIN PROP. CONTRACT, URIAL AGREEMENT TO	3				
Pump House # 97 REVISE PUMPING EQUIP. CONTRACT COPY ENCLOSED					
(\$Amt must equal the total from pg. 2, Line 7g, column 2: "This Request")					Total Disbursed \$

Type of Product or Service Codes:

- 3 = Construction
- 4 = Manufacturing
- 5 = Transportation
- 6 = Supplies & Equipment, Wholesale
- 7 = Supplies & Equipment, Retail
- 10 = Other
- 9 = Services
 - 9a = Business Services
 - 9b = Professional Services
 - 9c = Other
 - 9d = Professional Services

A. Reporting Requirements: Report on any procurement that is actually executed.
 B. Procurement: is the acquisition through order, purchase, lease or barter of supplies, equipment, construction services.
 C. Minority Business Enterprise (MBE): is a business concern that is (1) at least 51 percent owned by one or more minority individuals, or in the case of a publicly owned business, at least 51 percent owned by one or more minority owners, and (2) whose daily business operations are managed and directed by one or more of the minority owners.
 D. Women Business Enterprise (WBE): is a business concern that is (1) at least 51 percent owned by one or more women; and or, in the case of a publicly owned business, at least 51 percent of the stock is owned by one or more women; and whose daily business operations are managed and directed by one or more of the women owners.
 * (Business firms which are 51 percent owned by minorities or women, but are in fact managed and operated by individuals who are minorities or women; do not qualify for meeting MBE/WBE goals.)
 E. Small Business Enterprise in a Rural Area (SBRA): is a business concern that is physically located outside any state metropolitan statistical area.

SECTION

5

SECTION 5.0

Detail of Salaries and Wages Expense (Acct. 601)

DONALD J. UNTHANKPRESIDENT and GENERAL MANAGER
SALARY: \$100.00 per Month

DUTIES:

In overall control of administrative and field operations. Serves as Chairman of the Board of Directors (Board). Prepares budgets for expenses and investments for presentation to the Board. Supervises functions of Secretary-Treasurer of the Company. Supervises the Field Operations Supervisor's functions and issues instructions to him, when necessary, regarding his functions and duties. Supervises preparation of reports to governmental entities and often prepares some of these reports himself. Represents the Company in all discussions with governmental bodies. Reviews all accounting reports. When absent the Vice President acts in his place.

DOROTHY FREDERICKSECRETARY and TREASURER
SALARY: \$150.00 per Month

DUTIES:

Prepares and types most correspondence. Keeps minutes of Board meetings. Reviews most accounting reports. Approves invoices and forwards these to the Accounting firm contracted by the Company, and follows the work of the Accounting firm. Keeps and maintains many of the operating files of the Company. Types most reports to governmental agencies and maintains files of them. All meters are read by a contract employee. The meter reader records the meter reading on a tape recorder. The Secretary then transcribes the meter readings from the tape recorder onto forms, which are then forwarded to the Accounting firm for billing.

LOU FREDERICKFIELD OPERATIONS SUPERVISOR
SALARY: \$200.00 per Month

DUTIES:

Controls output of well on a daily basis and controls the gpm rate of CAP water taken from the City of Scottsdale system and placed into the Company's 64,000 gallon storage tank, from which the water then flows into the Company's distribution system. Places orders for supplies of material when needed. Samples water radiography tests and mails them. Samples taken under supervision of a contracted Certified operator. Alerts the President of any test results which are not satisfactory. When notified, Blue Stakes lines for contractors such as APS, Quest, etc. Is present for all excavation around Company lines.

LOU FREDERICKFIELD OPERATIONS SUPERVISOR (Continued)

Does all preventive maintenance and hires help for this when necessary. Shuts off all non-payment customers and turns them on again on instructions from the President. Operates the water treatment plant. Supervises all maintenance functions.

Performs certain plumbing functions for new hookups and other work, when within his area of skill. For these functions he is paid separately.

SECTION

6

SECTION 6.0

Company Name: Tonto Hills Utility Company	Test Year Ended: December 31, 2002
--	---------------------------------------

**SECTION 6
INVOICES FOR PURCHASED WATER DURING THE TEST YEAR (Acct. 610)**

CAP WATER

TYPE	DATE	NUMBER	NAME	MEMO	AMOUNT
CHECK	1/14/02	2670	CAP	N/A	\$744.44
CHECK	5/15/02	2746	CAP		\$1,526.50
CHECK	10/25/02	2827	CAP		\$1,526.50
CHECK	12/4/02	2858	CAP		\$792.00

N/A--NOT AVAILABLE

\$4,589.44

CITY OF SCOTTSDALE TREAT & TRANSPORT

TYPE	DATE	NUMBER	NAME	MEMO	AMOUNT
CHECK	1/3/02	2652	CITY OF SCOTTSDALE		\$1,591.50
CHECK	4/1/02	2666	CITY OF SCOTTSDALE		\$1,521.15
CHECK	5/5/02	2668	CITY OF SCOTTSDALE	N/A	\$1,854.02
CHECK	1/22/02	2671	CITY OF SCOTTSDALE		\$1,737.63
CHECK	3/4/02	2698	CITY OF SCOTTSDALE		\$1,540.63
CHECK	6/3/02	2735	CITY OF SCOTTSDALE	N/A	\$2,003.85
CHECK	7/2/02	2759	CITY OF SCOTTSDALE		\$2,411.20
CHECK	8/1/02	2765	CITY OF SCOTTSDALE	N/A	\$1,212.78
CHECK	9/3/02	2803	CITY OF SCOTTSDALE		\$1,081.64
CHECK	1/05/02	2817	CITY OF SCOTTSDALE		\$1,187.75
CHECK	11/4/02	2818	CITY OF SCOTTSDALE		\$1,807.50
CHECK	12/30/02	2871	CITY OF SCOTTSDALE		\$131.47

N/A--NOT AVAILABLE

\$18,081.12

TOTAL PURCHASED WATER

\$22,670.56



CENTRAL ARIZONA PROJECT

P.O. Box 42447
Phoenix, AZ 85080-2447

Invoice

BILL TO: Attn: Accounts Payable
TONTON HILLS UTILITY COMPANY
MR DONALD J UNTHANK
PRESIDENT
11802 E BLUE WASH RD
CAVE CREEK AZ 85331

NUMBER 12820
BILL DATE 15-APR-02
DUE DATE 20-MAY-02

CUSTOMER NUMBER 1385

DESCRIPTION	QTY	UOM	UNIT COST	TOTAL
END HALF SEMIANNUAL 2002 CAPITAL CHARGE	71	A/F	21.50	1,526.50
TOTAL DUE				\$1,526.50

Handwritten notes:
1526.50
DUE 20 MAY, 02
#2746
5/15/02

SPECIAL INSTRUCTIONS

SEMIANNUAL M&I WATER SERVICE CAPITAL CHARGE

Refer questions to Financial Services: 623-869-2149 • inquiries@cap-az.com



CENTRAL ARIZONA PROJECT

P.O. Box 42447
Phoenix, AZ 85080-2447

Invoice

BILL TO: DONALD UNTHANK
TONTON HILLS UTILITY COMPANY
MR DONALD J UNTHANK
PRESIDENT
11802 E BLUE WASH RD
CAVE CREEK AZ 85331

NUMBER 14421
BILL DATE 15-OCT-02
DUE DATE 20-NOV-02
CUSTOMER NUMBER 1385

DESCRIPTION	QTY	UOM	UNIT COST	TOTAL
003 CAPITAL CHARGE; 1ST HALF	71	A/F	21.50	1,526.50
TOTAL DUE				\$1,526.50

*Pd 10/30/02
chk # 2827*

SPECIAL INSTRUCTIONS
2003 SEMIANNUAL M&I WATER SERVICE CAPITAL CHARGE

Refer questions to Financial Services: 623-869-2149 • inquiries@cap-az.com



CENTRAL ARIZONA PROJECT

P.O. Box 42447
Phoenix, AZ 85080-2447

Invoice

DONALD J UNTHANK
BILL TO: TONTO HILLS UTILITY COMPANY
MR DONALD J UNTHANK
PRESIDENT
11802 E BLUE WASH RD
CAVE CREEK AZ 85331

NUMBER 15627
BILL DATE 10-NOV-02
DUE DATE 20-DEC-02
CUSTOMER NUMBER 1385

DESCRIPTION	QTY	UOM	UNIT COST	TOTAL
WATER; SUBCONTRACT M&I	1	LS	792.00	792.00
TOTAL DUE				\$792.00

*PD 12-4-02
CK 2858*

SPECIAL INSTRUCTIONS
WATER SERVICE CHARGE PREPAYMENT FOR 2003

Refer questions to Financial Services: 623-869-2149 • inquiries@cap-az.com

PERIOD COVERED: 11/13/01 - 12/13/01 | **BILL DUE UPON RECEIPT - DELINQUENT DATE: 01/09/02**

WATER ENVIRONMENTAL

BASE FEE	21.77	AZ WTR QUALITY TAX	4.18
TITLE FEE	1413.64	WATER QUALITY	38.43
TAX	20.63		
STATE TAX	92.85		
	<u>1548.89</u>		<u>42.61</u>
TOTAL CURRENT CHARGES			1591.50

CURRENT METER READING : 468104
 METER SIZE : 1" MULTIPLIER : 10
 USAGE-GALS : 642450
 # OF BILLING DAYS: 30

- Use 312-PAYS for Automated Payment &
- Balance Information 480-312-7297
 - General Billing Information 480-312-2461
 - Delinquent Utility Accounts 480-312-2705
 - Solid Waste Collection 480-312-5800
 - Goal Billing Information 480-312-5598
 - Water Operations, meter leaks 480-312-5650
 - Water Conservation Information 480-312-5690
 - Scottsdale Homepage www.ci.scottsdale.az.us

GRAND TOTAL	1591.50
--------------------	----------------

PLEASE NOTE IMPORTANT INFORMATION ON BACK OF STATEMENT !

ck # 2652

Because of YOU, we're a better community! Many thanks to our Scottsdale Cares donors for caring about social service needs in Scottsdale. Your dollar, combined with contributions from The Arizona Republic Charities, helps youth, families and senior citizens. Visit www.ci.scottsdale.az.us/humanservices for more information.

If you choose to contribute to this program, please enclose a separate check to: Scottsdale Cares.

CITY OF SCOTTSDALE 7447 E. INDIAN SCHOOL, SUITE 110 AND 9379 E. SAN SALVADOR DR. STE. 100

WATER ENVIRONMENTAL

BASE FEE	21.77	AZ WTR QUALITY TAX	4.56
FEE	1545.44	WATER QUALITY	41.95
TAX	22.53		
STATE TAX	101.38		
	<u>1691.12</u>		<u>46.51</u>

TOTAL CURRENT CHARGES 1737.63

CURRENT METER READING : 538286
 METER SIZE : 1" MULTIPLIER : 10
 USAGE-GALS : 701820
 # OF BILLING DAYS: 34

Use 312-PAYS for Automated Payment &
 Balance Information 480-312-7297
 General Billing Information 480-312-2461
 Delinquent Utility Accounts 480-312-2705
 Solid Waste Collection 480-312-5800
 Goal Billing Information 480-312-5598
 Water Operations, meter leaks 480-312-5650
 Water Conservation Information 480-312-5690
 Scottsdale Homepage www.ci.scottsdale.az.us

2767 2671
 1/22/02

GRAND TOTAL 1737.63

PLEASE NOTE IMPORTANT INFORMATION ON BACK OF STATEMENT I

Because of YOU, we're a better community! Many thanks to our Scottsdale Cares donors for caring about social service needs in Scottsdale. Your dollar, combined with contributions from The Arizona Republic Charities, helps youth, families and senior citizens. Visit www.ci.scottsdale.az.us/humanservices for more information.

If you choose to contribute to this program, please enclose a separate check to: Scottsdale Cares.

CITY OF SCOTTSDALE 7447 E. INDIAN SCHOOL, SUITE 110 AND 9379 E. SAN SALVADOR DR. STE. 100

ACCT. NBR.: 00 000 094 856 01 01 SERVICE ADDRESS: HYDRANT LAST PAYMENT: \$1,737.63 02/01/02

PERIOD COVERED: 01/16/02 - 02/13/02 BILL DUE UPON RECEIPT - DELINQUENT DATE: 03/13/02

WATER		ENVIRONMENTAL	
FEE 21.77 USAGE FEE 1367.77 CITY TAX 19.97 STATE TAX 89.88 <hr/> 1499.39	AZ WTR QUALITY TAX 4.04 WATER QUALITY 37.20 <hr/> 41.24		
TOTAL CURRENT CHARGES			1540.63

CURRENT METER READING : 600465
 METER SIZE : 1" MULTIPLIER : 10
 USAGE-GALS : 621790
 # OF BILLING DAYS: 28
 Use 312-PAYS for Automated Payment &
 Balance Information 480-312-7297
 General Billing Information 480-312-2461
 Delinquent Utility Accounts 480-312-2705
 Solid Waste Collection 480-312-5600
 Goal Billing Information 480-312-5598
 Water Operations, meter leaks 480-312-5650
 Water Conservation Information 480-312-5690
 Scottsdale Homepage www.ci.scottsdale.az.us

2698
3/4/02

GRAND TOTAL 1540.63

PLEASE NOTE IMPORTANT INFORMATION ON BACK OF STATEMENT I

THANK YOU for caring Scottsdale! In 2001, Scottsdale residents contributed \$146,000 to Scottsdale Cares to help others in need in our community. Your dollars are providing services such as home-delivered meals for shut-ins, crisis shelter for children, job training for the disabled, and services for the deaf. For more information, please call (480) 312-2464.

If you choose to contribute to this program, please enclose a separate check to: Scottsdale Cares.

ACCT. NBR.: 00 000 094 856 01 01 SERVICE ADDRESS: HYDRANT LAST PAYMENT: \$1,540.63 03/12/02

PERIOD COVERED: 02/13/02 - 03/14/02 BILL DUE UPON RECEIPT - DELINQUENT DATE: 04/05/02

WATER

ENVIRONMENTAL

FEE 21.77
 USAGE FEE 1350.19
 CITY TAX 19.72
 STATE TAX 88.75

AZ WTR QUALITY TAX 3.99
 WATER QUALITY 36.73

1480.43

40.72

TOTAL CURRENT CHARGES

1521.15

CURRENT METER READING : 661852
 METER SIZE : 1" MULTIPLIER : 10
 USAGE-GALS : 613870
 # OF BILLING DAYS: 29

Use 312-PAYS for Automated Payment &

Balance Information 480-312-7297
 General Billing Information 480-312-2461
 Delinquent Utility Accounts 480-312-2705
 Solid Waste Collection 480-312-5600
 Goal Billing Information 480-312-5598
 Water Operations, meter leaks 480-312-5650
 Water Conservation Information 480-312-5690
 Scottsdale Homepage www.ci.scottsdale.az.us

GRAND TOTAL

1521.15

PLEASE NOTE IMPORTANT INFORMATION ON BACK OF STATEMENT !

*ck # 2666
 3-30-02*

THANK YOU for caring Scottsdale! In 2001, Scottsdale residents contributed \$146,000 to Scottsdale Cares to help others in need in our community. Your dollars are providing services such as home-delivered meals for shut-ins, crisis shelter for children, job training for the disabled, and services for the deaf. Visit www.ci.scottsdale.az.us/humanservices for more information.

If you choose to contribute to this program, please enclose a separate check to: Scottsdale Cares.

ACCT. NBR.: 00 000 094 856 01 01 SERVICE ADDRESS: HYDRANT LAST PAYMENT: \$2,003.85 06/05/02

PERIOD COVERED: 05/13/02 - 06/13/02 BILL DUE UPON RECEIPT - DELINQUENT DATE: 07/08/02

WATER

ENVIRONMENTAL

FEE 21.77
 USAGE FEE 2152.94
 CITY TAX 31.26
 STATE TAX 140.67

AZ WTR QUALITY TAX 6.34
 WATER QUALITY 58.22

2346.64

64.56

TOTAL CURRENT CHARGES 2411.20

CURRENT METER READING: 915307
 METER SIZE: 1" MULTIPLIER: 10
 USAGE-GALS: 975470
 # OF BILLING DAYS: 31

Use 312-PAYS for Automated Payment &
 Balance Information 480-312-7297
 General Billing Information 480-312-2461
 Delinquent Utility Accounts 480-312-2705
 Solid Waste Collection 480-312-5600
 Goal Billing Information 480-312-5598
 Water Operations, meter leaks 480-312-5650
 Water Conservation Information 480-312-5690
 Scottsdale Homepage www.ci.scottsdale.az.us

GRAND TOTAL 2411.20

PLEASE NOTE IMPORTANT INFORMATION ON BACK OF STATEMENT I

*Ch 2759
 July 21, 2002*

THANK YOU for caring Scottsdale! In 2001, Scottsdale residents contributed \$146,000 to Scottsdale Cares to help others in need in our community. Your dollars are providing services such as home-delivered meals for shut-ins, crisis shelter for children, job training for the disabled, and services for the deaf. Visit www.ci.scottsdale.az.us/humanservices for more information.

If you choose to contribute to this program, please enclose a separate check to: Scottsdale Cares.

ACCT. NBR.: 00 000 094 856 01 01 SERVICE ADDRESS: HYDRANT LAST PAYMENT: \$1,212.78 08/06/02

PERIOD COVERED: 07/17/02 - 08/13/02 BILL DUE UPON RECEIPT - DELINQUENT DATE: 09/06/02

WATER		ENVIRONMENTAL	
FEE	21.77	AZ WTR QUALITY TAX	2.83
USAGE FEE	953.79	WATER QUALITY	26.12
CITY TAX	14.02		
STATE TAX	63.11		
	<u>1052.69</u>		<u>28.95</u>
			#2803 9/3/02
			TOTAL CURRENT CHARGES 1081.64

CURRENT METER READING : 7697
 METER SIZE : 1" MULTIPLIER : 10
 USAGE-GALS : 435310
 # OF BILLING DAYS: 27

Use 312-PAYS for Automated Payment &
 Balance Information 480-312-7297
 General Billing Information 480-312-2461
 Delinquent Utility Accounts 480-312-2705
 Solid Waste Collection 480-312-5600
 Goal Billing Information 480-312-5598
 Water Operations, meter leaks 480-312-5650
 Water Conservation Information 480-312-5690
 Scottsdale Homepage www.ci.scottsdale.az.us

GRAND TOTAL	1081.64

PLEASE NOTE IMPORTANT INFORMATION ON BACK OF STATEMENT I

THANK YOU for caring Scottsdale! In 2001, Scottsdale residents contributed \$146,000 to Scottsdale Cares to help others in need in our community. Your dollars are providing services such as home-delivered meals for shut-ins, crisis shelter for children, job training for the disabled, and services for the deaf. Visit www.ci.scottsdale.az.us/humanservices for more information.

If you choose to contribute to this program, please enclose a separate check to: Scottsdale Cares.

CITY OF SCOTTSDALE 7447 E. INDIAN SCHOOL, SUITE 110 AND 9379 E. SAN SALVADOR DR. STE. 100

ACCT. NBR.: 00 000 094 856 01 01 SERVICE ADDRESS: HYDRANT LAST PAYMENT: \$1,081.64 09/06/02

PERIOD COVERED: 08/13/02 - 09/16/02 BILL DUE UPON RECEIPT - DELINQUENT DATE: 10/09/02

WATER		ENVIRONMENTAL	
FEE	21.77	AZ WTR QUALITY TAX	3.11
USAGE FEE	1049.49	WATER QUALITY	28.68
CITY TAX	15.40		
STATE TAX	69.30		
	<u>1155.96</u>		<u>31.79</u>
			TOTAL CURRENT CHARGES
			1187.75

CURRENT METER READING : 55539
 METER SIZE : 1" MULTIPLIER : 10
 USAGE-GALS : 478420
 # OF BILLING DAYS: 34

Use 312-PAYS for Automated Payment &
 Balance Information 480-312-7297
 General Billing Information 480-312-2461
 Delinquent Utility Accounts 480-312-2705
 Solid Waste Collection 480-312-5600
 Goal Billing Information 480-312-5598
 Water Operations, meter leaks 480-312-5650
 Water Conservation Information 480-312-5690
 Scottsdale Homepage www.ci.scottsdale.az.us

		GRAND TOTAL	1187.75
--	--	-------------	---------

PLEASE NOTE IMPORTANT INFORMATION ON BACK OF STATEMENT I

*check # 2817
10/5/02*

THANK YOU for caring Scottsdale! In 2001, Scottsdale residents contributed \$146,000 to Scottsdale Cares to help others in need in our community. Your dollars are providing services such as home-delivered meals for shut-ins, crisis shelter for children, job training for the disabled, and services for the deaf. Visit www.ci.scottsdale.az.us/humanservices for more information.

If you choose to contribute to this program, please enclose a separate check to: Scottsdale Cares.

CITY OF SCOTTSDALE 7447 E. INDIAN SCHOOL, SUITE 110 AND 9379 E. SAN SALVADOR DR. STE. 100

ACCT. NBR.: 00 000 094 856 01 01 SERVICE ADDRESS: HYDRANT LAST PAYMENT: \$1,081.64 09/06/02

PERIOD COVERED: 09/16/02 - 10/15/02 BILL DUE UPON RECEIPT - DELINQUENT DATE: 11/04/02

WATER		ENVIRONMENTAL	
BASE FEE	21.77	AZ WTR QUALITY TAX	1.61
USAGE FEE	537.21	WATER QUALITY	14.96
CITY TAX	8.04		
STATE TAX	36.16		
<hr/>		<hr/>	
603.18		16.57	
TOTAL CURRENT CHARGES			619.75

CURRENT METER READING : 80305 METER SIZE : 1" MULTIPLIER : 10 USAGE-GALS : 247660 # OF BILLING DAYS: 29	PREVIOUS BALANCE	1187.75
Use 312-PAYS for Automated Payment & Balance Information 480-312-7297 General Billing Information 480-312-2461 Delinquent Utility Accounts 480-312-2705 Solid Waste Collection 480-312-5600 Goal Billing Information 480-312-5598 Water Operations, meter leaks 480-312-5650 Water Conservation Information 480-312-5690 Scottsdale Homepage www.ci.scottsdale.az.us	<i># 2818</i> <i>11/04/02</i>	
GRAND TOTAL		1807.50

PLEASE NOTE IMPORTANT INFORMATION ON BACK OF STATEMENT I

Just a reminder that the previous balance on this bill is overdue. To avoid a possible interruption of service, please send your check today. If payment has been made, please accept our thanks.

A late charge of \$5.00 is assessed on any past due balance if payment is not received by the delinquent shown on your statement.

 **THANK YOU** for caring Scottsdale! In 2001, Scottsdale residents contributed \$146,000 to Scottsdale Cares to help others in need in our community. Your dollars are providing services such as home-delivered meals for shut-ins, crisis shelter for children, job training for the disabled, and services for the deaf. Visit www.ci.scottsdale.az.us/humanservices for more information.

If you choose to contribute to this program, please enclose a separate check to: Scottsdale Cares.

PAY YOUR BILL ON-LINE AT- <https://eservices.ci.scottsdale.az.us/ubonline>

CITY OF SCOTTSDALE 7447 E. INDIAN SCHOOL, SUITE 110 AND 9379 E. SAN SALVADOR DR. STE. 100

ACCT. NBR.: 00 000 094 856 01 01 SERVICE ADDRESS: HYDRANT LAST PAYMENT: \$1,807.50 11/06/02

PERIOD COVERED: 11/18/02 - 12/17/02 BILL DUE UPON RECEIPT - DELINQUENT DATE: 01/08/03

WATER

ENVIRONMENTAL

BASE FEE 22.86
 USAGE FEE 547.48
 CITY TAX 8.20
 STATE TAX 36.89

AZ WTR QUALITY TAX 1.56
 WATER QUALITY 15.27

615.43

16.83

TOTAL CURRENT CHARGES 632.26

CURRENT METER READING : 131155
 METER SIZE : 1" MULTIPLIER : 10
 USAGE-GALS : 240650
 # OF BILLING DAYS: 29

PREVIOUS BALANCE

-500.79

Use 312-PAYS for Automated Payment &
 Balance Information 480-312-7297
 General Billing Information 480-312-2461
 Delinquent Utility Accounts 480-312-2705
 Solid Waste Collection 480-312-5600
 Goal Billing Information 480-312-5598
 Water Operations, meter leaks 480-312-5650
 Water Conservation Information 480-312-5690
 Scottsdale Homepage www.scottsdaleaz.gov

GRAND TOTAL 131.47

PLEASE NOTE IMPORTANT INFORMATION ON BACK OF STATEMENT !

*Pd 12/30/02
 #8871*

THANK YOU for caring Scottsdale! In 2001, Scottsdale residents contributed \$146,000 to Scottsdale Cares to help others in need in our community. Your dollars are providing services such as home-delivered meals for shut-ins, crisis shelter for children, job training for the disabled, and services for the deaf. Visit www.ci.scottsdale.az.us/humanservices for more information.

If you choose to contribute to this program, please enclose a separate check to: Scottsdale Cares.

PAY YOUR BILL ON-LINE AT- <https://eservices.scottsdaleaz.gov/ubonline>

SECTION

7

SECTION 7.0

Company Name: Tonto Hills Utility Company	Test Year Ended: December 31, 2002
--	---------------------------------------

**SECTION 7
INVOICES FOR PURCHASED POWER DURING THE TEST YEAR (Acct. 615)**

APS POWER

TYPE	DATE	NUMBER	NAME	MEMO	AMOUNT
CHECK	1/30/02	2679	APS		\$59.38
CHECK	2/28/02	2697	APS		\$31.94
CHECK	3/27/02	2712	APS		\$31.94
CHECK	5/3/02	2742	APS		\$37.30
CHECK	5/30/02	2750	APS		\$40.88
CHECK	6/27/02	2768	APS		\$39.10
CHECK	8/5/02	2789	APS	N/A	\$114.11
CHECK	8/5/02	2790	APS	N/A	\$264.45
CHECK	8/20/02	2797	APS		\$462.15
CHECK	10/30/02	2824	APS		\$418.90
CHECK	10/30/02	2837	APS		\$521.65
CHECK	11/25/02	2855	APS		\$560.48
N/A NOT AVAILABLE					\$2,582.28



Post Office Box 2907
Phoenix, AZ 85062-2907

TONTO HILLS UTILITY CO
Your Account Number
Billing Date

038012289
Jan 17, 2002

Page 1 of 2
Questions? Visit our website at www.aps.com or
call 602-371-6767, 24 hours a day, 7 days a week.
Para servicio en español llame al 602-371-6861.

Previous Balance as of 12/17/2001	Payments Received	Current Charges	Total Due by 01/31/2002
19.76	19.76 cr	15.97	15.97

SERVICE INFORMATION

Service number 475TS90289
Your service plan E-221 Rate
Service address 42841 N LA Plata Rd

Your meter number 778116
Your meter is read in cycle 09

On Jan 10 your total kWh read was 83237
On Dec 11 your total kWh read was 83237
Your total kWh usage is 0
Your kW demand read was 0

CURRENT CHARGES

Basic service charge 15.00
Charge for kWh used 0.00
Charge for kW demand 0.00
ACC mandated environmental surcharge 0.00
Regulatory assessment 0.02
Sales tax 0.95
Total current charges 15.97

ENERGY USE COMPARISON			
	This Month	Last Month	Last Year
Days	30	33	30
kW	0	2	11
Daily kWh	0	0	0
Daily Cost \$	0.53	0.59	1.19

Thank you for your payment of \$19.76 received on 01/03/2002

#2679
1/30/02

Continued on next page
When paying in person, please bring bottom portion of this bill.



Post Office Box 2907
Phoenix, AZ 85062-2907

TONTO HILLS UTILITY CO
Your Account Number
Billing Date

336960288
Jan 17, 2002

Questions? Visit our website at www.aps.com or
call 602-371-6767, 24 hours a day, 7 days a week.
Para servicio en español llame al 602-371-8861.

Previous Balance as of 12/17/2001	Payments Received	Current Charges	Total Due by 01/31/2002
90.65	90.65 cr	43.41	43.41

SERVICE INFORMATION

Service number 0603S30288
Your service plan E-221 Rate
Service address 11950 E Blue Wash Rd
Well 4

Your meter number 557639
Your meter is read in cycle 09

On Jan 10 your total kWh read was 96534
On Dec 11 your total kWh read was 96443
Your total kWh usage is 91
Your kW demand read was 10

CURRENT CHARGES

Basic service charge 15.00
Charge for kWh used 8.89
Charge for kW demand 16.80
ACC mandated environmental surcharge 0.08
Regulatory assessment 0.06
Sales tax 2.58
Total current charges 43.41

ENERGY USE COMPARISON			
	This Month	Last Month	Last Year
Days	30	33	30
kW	10	10	10
Daily kWh	3	20	4
Daily Cost \$	1.44	2.74	1.60

Thank you for your payment of \$90.65 received on 01/03/2002

Continued on next page
When paying in person, please bring bottom portion of this bill.



Post Office Box 2907
Phoenix, AZ 85062-2907

TONTO HILLS UTILITY CO
Your Account Number
Billing Date

336960288
Feb 18, 2002

Questions? Visit our website at www.aps.com or
call 602-371-6767, 24 hours a day, 7 days a week.
Para servicio en español llame al 602-371-6861.

Previous Balance as of 01/17/2002	Payments Received	Current Charges	Total Due by 02/01/2002
43.41	43.41 cr	15.97	15.97

**A FAST WAY
TO PAY YOUR
APS BILL**

Anytime, 24 hours a day, you can pay your APS bill with your American Express, Discover, or Visa card by calling BillMatrix at 1-800-511-2385.

BillMatrix will charge you \$5.95 for this service.

When you call, you will need to have your APS account number, your credit card number and expiration date, as well as your 5 digit zip code on your credit card statement.

SERVICE INFORMATION

Service number 0603S30288
Your service plan E-221 Rate
Service address 11950 E Blue Wash Rd
Well 4

Your meter number 557639
Your meter is read in cycle 09

On Feb 11 your total kWh read was 96534
On Jan 10 your total kWh read was 96534
Your total kWh usage is 0

Your kW demand read was 0

CURRENT CHARGES

Basic service charge	15.00
Charge for kWh used	0.00
Charge for kW demand	0.00
ACC mandated environmental surcharge	0.00
Regulatory assessment	0.02
Sales tax	0.95
Total current charges	15.97

ENERGY USE COMPARISON			
	This Month	Last Month	Last Year
Days	32	30	30
kW	0	10	0
Daily kWh	0	3	0
Daily Cost \$	0.49	1.44	0.53

Thank you for your payment of \$43.41 received on 02/01/2002

*#2697
3/4/02*

Continued on next page
When paying in person, please bring bottom portion of this bill.



Post Office Box 2907
Phoenix, AZ 85062-2907

TONTO HILLS UTILITY CO
Your Account Number
Billing Date

038012289
Feb 18, 2002

Questions? Visit our website at www.aps.com or
call 602-371-6767, 24 hours a day, 7 days a week.
Para servicio en español llame al 602-371-6881.

Previous Balance as of 01/17/2002	Payments Received	Current Charges	Total Due by 03/01/2002
15.97	15.97 cr	15.97	15.97

**A FAST WAY
TO PAY YOUR
APS BILL**

Anytime, 24 hours a day, you can pay your APS bill with your American Express, Discover, or Visa card by calling BillMatrix at 1-800-511-2385.

BillMatrix will charge you \$5.95 for this service.

When you call, you will need to have your APS account number, your credit card number and expiration date, as well as the 5 digit zip code on your credit card statement.

SERVICE INFORMATION

Service number 4751S90289
Your service plan E-221 Rate
Service address 42841 N LA Plata Rd

Your meter number 778116
Your meter is read in cycle 09

On Feb 11 your total kWh read was 83237
On Jan 10 your total kWh read was 83237
Your total kWh usage is 0
Your kW demand read was 0

CURRENT CHARGES

Basic service charge 15.00
Charge for kWh used 0.00
Charge for kW demand 0.00
ACC mandated environmental surcharge 0.00
Regulatory assessment 0.02
Sales tax 0.95
Total current charges 15.97

ENERGY USE COMPARISON			
	This Month	Last Month	Last Year
Days	32	30	30
kW	0	0	11
Daily kWh	0	0	0
Daily Cost \$	0.49	0.53	1.19

Thank you for your payment of \$15.97 received on 02/01/2002

Continued on next page
When paying in person, please bring bottom portion of this bill.



Post Office Box 2907
Phoenix, AZ 85062-2907

TONTO HILLS UTILITY CO
Your Account Number
Billing Date

336960288
Mar 18, 2002

Questions? Visit our website at www.aps.com or
call 602-371-8787, 24 hours a day, 7 days a week.
Para servicio en español llame al 602-371-8881.

Previous Balance as of 02/18/2002	Payments Received	Current Charges	Total Due by 03/29/2002
15.97	15.97 cr	15.97	15.97

SERVICE INFORMATION

Service number 0603S30288
Your service plan E-221 Rate
Service address 11950 E Blue Wash Rd
Well 4

Your meter number 557639
Your meter is read in cycle 09

On Mar 13 your total kWh read was
On Feb 11 your total kWh read was
Your total kWh usage is

96534
96534
0

Your kW demand read was

0

CURRENT CHARGES

Basic service charge
Charge for kWh used
Charge for kW demand
ACC mandated environmental surcharge
Regulatory assessment
Sales tax
Total current charges

15.00
0.00
0.00
0.00
0.02
0.95
15.97

ENERGY USE COMPARISON			
	This Month	Last Month	Last Year
Days	30	32	32
Daily kWh	0	0	0
Daily Cost \$	0.53	0.49	0.49

Thank you for your payment of \$15.97 received on 03/07/2002

*DR 2712
3/20 @ 31.94*

Continued on next page
When paying in person, please bring bottom portion of this bill.



Post Office Box 2907
Phoenix, AZ 85062-2907

TONTO HILLS UTILITY CO
Your Account Number
Billing Date

038012289
Mar 18, 2002

Questions? Visit our website at www.aps.com or
call 602-371-6767, 24 hours a day, 7 days a week.
Para servicio en español llame al 602-371-6861.

Previous Balance as of 02/18/2002	Payments Received	Current Charges	Total Due by 03/28/2002
15.97	15.97 cr	15.97	15.97

SERVICE INFORMATION

Service number 4751S90289
Your service plan E-221 Rate
Service address 42841 N LA Plata Rd

Your meter number 778116
Your meter is read in cycle 09

On Mar 13 your total kWh read was 83237
On Feb 11 your total kWh read was 83237
Your total kWh usage is 0

Your kW demand read was 0

CURRENT CHARGES

Basic service charge	15.00
Charge for kWh used	0.00
Charge for kW demand	0.00
ACC mandated environmental surcharge	0.00
Regulatory assessment	0.02
Sales tax	0.95
Total current charges	15.97

ENERGY USE COMPARISON			
	This Month	Last Month	Last Year
Days	30	32	32
kW	0	0	11
Daily kWh	0	0	0
Daily Cost \$	0.53	0.49	1.11

Thank you for your payment of \$15.97 received on 03/07/2002

*OK. 2717 (a)
3/28 - 431.94*

Continued on next page
When paying in person, please bring bottom portion of this bill.



Post Office Box 2907
Phoenix, AZ 85062-2907

TONTO HILLS UTILITY CO
Your Account Number
Billing Date

038012289
Apr 16, 2002

Questions? Visit our website at www.aps.com or
call 602-371-6767, 24 hours a day, 7 days a week.
Para servicio en español llame al 602-371-6861.

Previous Balance as of 03/18/2002	Payments Received	Current Charges	Total Due by 04/29/2002
15.97	15.97 cr	21.33	21.33

SERVICE INFORMATION

Service number 4751S90289
Your service plan E-221 Rate
Service address 42841 N LA Plata Rd

Your meter number 778116
Your meter is read in cycle 09

On Apr 12 your total kWh read was 83237
On Mar 13 your total kWh read was 83237
Your total kWh usage is 0
* Your billing kW demand is 3

CURRENT CHARGES

Basic service charge 0.00
* Charge for kWh used 20.04
Charge for kW demand 0.00
ACC mandated environmental surcharge 0.00
Regulatory assessment 0.03
Sales tax 1.26
Total current charges 21.33

ENERGY USE COMPARISON			
	This Month	Last Month	Last Year
Days	30	30	30
kW	3	0	11
Daily kWh	0	0	0
Daily Cost \$	0.71	0.53	1.19

Thank you for your payment of \$15.97 received on 04/02/2002

* kWh Charge is a minimum charge

*Pd ck 2742
5/3 - 21.33
15.97
37.30*

Continued on next page
When paying in person, please bring bottom portion of this bill.



Billing Date
Apr 16, 2002

Account Number
038012289

Account Number
038012289

Billing Date
Apr 16, 2002

1199.5.173.29654 1 AV 0.255



TONTO HILLS UTILITY CO
C/O TONTO HILLS # 41
11431 E MANANA RD
CAVE CREEK AZ 85331-2873

ENTER AMOUNT ENCLOSED

MAKE CHECK
PAYABLE TO: APS

ENTER S.H.A.R.E. AMOUNT

Check No. _____

Date paid _____

Amount _____

09 N 1 82

If contributing to S.H.A.R.E.
please enter amount in S.H.A.R.E.
box and add to your total

TOTAL AMOUNT OF
\$21.33
DUE BY 04/29/2002

**KEEP THIS STUB
PORTION FOR
YOUR RECORDS**

00000000038012289802002041600000000000000213323 000



Post Office Box 2907
Phoenix, AZ 85062-2907

TONTO HILLS UTILITY CO
Your Account Number
Billing Date

336960288
Apr 16, 2002

Questions? Visit our website at www.aps.com or
call 602-371-8787, 24 hours a day, 7 days a week.
Para servicio en español llame al 602-371-8861.

Previous Balance as of 03/18/2002	Payments Received	Current Charges	Total Due by 04/29/2002
15.97	15.97 cr	15.97	15.97

SERVICE INFORMATION

Service number 0603S30288
Your service plan E-221 Rate
Service address 11950 E Blue Wash Rd
Well 4

Your meter number 557639
Your meter is read in cycle 09

On Apr 12 your total kWh read was 96534
On Mar 13 your total kWh read was 96534
Your total kWh usage is 0

Your kW demand read was 0

CURRENT CHARGES

Basic service charge 15.00
Charge for kWh used 0.00
Charge for kW demand 0.00
ACC mandated environmental surcharge 0.00
Regulatory assessment 0.02
Sales tax 0.95
Total current charges 15.97

ENERGY USE COMPARISON			
	This Month	Last Month	Last Year
Days	30	30	30
kW	0	0	8
Daily kWh	0	0	1
Daily Cost \$	0.53	0.53	1.15

Thank you for your payment of \$15.97 received on 04/02/2002

Continued on next page
When paying in person, please bring bottom portion of this bill.



Billing Date
Apr 16, 2002

Account Number
336960288

Account Number
336960288

Billing Date
Apr 16, 2002

1199.5.173.29655 1 AV 0.255



ENTER AMOUNT ENCLOSED

MAKE CHECK
PAYABLE TO: APS

TONTO HILLS UTILITY CO
C/O TONTO HILLS #41
11431 E MANANA RD
CAVE CREEK AZ 85331-2873

ENTER S.H.A.R.E. AMOUNT

Check No. _____

Date paid _____

Amount _____

09 N 1 81

If contributing to S.H.A.R.E.
please enter amount in S.H.A.R.E.
box and add to your total

TOTAL AMOUNT OF
\$15.97
DUE BY 04/29/2002

**KEEP THIS STUB
PORTION FOR
YOUR RECORDS**

00000000336960288202002041600000000000000159706 000



Post Office Box 2907
Phoenix, AZ 85062-2907

TONTO HILLS UTILITY CO
Your Account Number
Billing Date

038012289
May 15, 2002

Questions? Visit our website at www.aps.com or
call 602-371-6767, 24 hours a day, 7 days a week.
Para servicio en español llame al 602-371-6861.

Previous Balance as of 04/16/2002	Payments Received	Current Charges	Total Due by 05/29/2002
21.33	21.33 cr	21.33	21.33

SERVICE INFORMATION

Service number 4751S90289
Your service plan E-221 Rate
Service address 42841 N LA Plata Rd

Your meter number 778116
Your meter is read in cycle 09

On May 13 your total kWh read was 83237
On Apr 12 your total kWh read was 83237
Your total kWh usage is 0

* Your billing kW demand is 3

CURRENT CHARGES

Basic service charge 0.00
* Charge for kWh used 20.04
Charge for kW demand 0.00
ACC mandated environmental surcharge 0.00
Regulatory assessment 0.03
Sales tax 1.26
Total current charges 21.33

ENERGY USE COMPARISON			
	This Month	Last Month	Last Year
Days	31	30	29
kW	3	3	11
Daily kWh	0	0	0
Daily Cost \$	0.68	0.71	1.23

Thank you for your payment of \$21.33 received on 05/07/2002

* kWh Charge is a minimum charge

Continued on next page
When paying in person, please bring bottom portion of this bill.

0.00 *
0.00 *
21.33 +
19.55 +
40.88 *

*WR #2759
5/30*



Post Office Box 2907
Phoenix, AZ 85062-2907

TONTO HILLS UTILITY CO
Your Account Number
Billing Date

336960288
May 15, 2002

Questions? Visit our website at www.aps.com or
call 602-371-8787, 24 hours a day, 7 days a week.
Para servicio en español llame al 602-371-8861.

Previous Balance as of 04/16/2002	Payments Received	Current Charges	Total Due by 05/29/2002
15.97	15.97 cr	19.55	19.55

SERVICE INFORMATION

Service number 0603S30288
Your service plan E-221 Rate
Service address 11950 E Blue Wash Rd
Well 4

Your meter number 557639
Your meter is read in cycle 09

On May 13 your total kWh read was 96534
On Apr 12 your total kWh read was 96534
Your total kWh usage is 0

Your kW demand read was 2

CURRENT CHARGES

Basic service charge 15.00
Charge for kWh used 0.00
Charge for kW demand 3.36
ACC mandated environmental surcharge 0.00
Regulatory assessment 0.03
Sales tax 1.16
Total current charges 19.55

ENERGY USE COMPARISON			
	This Month	Last Month	Last Year
Days	31	30	29
kW	2	0	10
Daily kWh	0	0	3
Daily Cost \$	0.63	0.53	1.55

Thank you for your payment of \$15.97 received on 05/07/2002

Continued on next page
When paying in person, please bring bottom portion of this bill.



Post Office Box 2907
Phoenix, AZ 85062-2907

TONTO HILLS UTILITY CO
Your Account Number
Billing Date

336960288
Jun 14, 2002

Questions? Visit our website at www.aps.com or
call 602-371-6767, 24 hours a day, 7 days a week.
Para servicio en español llame al 602-371-6861.

Previous Balance as of 05/15/2002	Payments Received	Current Charges	Total Due by 06/27/2002
19.55	19.55 cr	17.77	17.77

SERVICE INFORMATION

Service number 0603S30288
Your service plan E-221 Rate
Service address 11950 E Blue Wash Rd
Well 4

Your meter number 557639
Your meter is read in cycle 09

On Jun 12 your total kWh read was 96534
On May 13 your total kWh read was 96534
Your total kWh usage is 0

Your kW demand read was 1

CURRENT CHARGES

Basic service charge 15.00
Charge for kWh used 0.00
Charge for kW demand 1.68
ACC mandated environmental surcharge 0.00
Regulatory assessment 0.03
Sales tax 1.06
Total current charges 17.77

ENERGY USE COMPARISON			
	This Month	Last Month	Last Year
Days	30	31	33
kW	1	2	10
Daily kWh	0	0	4
Daily Cost \$	0.59	0.63	1.48

Thank you for your payment of \$19.55 received on 06/03/2002

2768
4/27/02

Continued on next page
When paying in person, please bring bottom portion of this bill.



Post Office Box 2907
Phoenix, AZ 85062-2907

TONTO HILLS UTILITY CO
Your Account Number
Billing Date

038012289
Jun 14, 2002

Questions? Visit our website at www.aps.com or
call 602-371-6767, 24 hours a day, 7 days a week.
Para servicio en español llame al 602-371-6861.

Previous Balance as of 05/15/2002	Payments Received	Current Charges	Total Due by 06/27/2002
21.33	21.33 cr	21.33	21.33

SERVICE INFORMATION

Service number 475TS90289
Your service plan E-221 Rate
Service address 42841 N LA Plata Rd

Your meter number 778116
Your meter is read in cycle 09

On Jun 12 your total kWh read was 83237
On May 13 your total kWh read was 83237
Your total kWh usage is 0
* Your billing kW demand is 3

CURRENT CHARGES

Basic service charge 0.00
* Charge for kWh used 20.04
Charge for kW demand 0.00
ACC mandated environmental surcharge 0.00
Regulatory assessment 0.03
Sales tax 1.26
Total current charges 21.33

ENERGY USE COMPARISON			
	This Month	Last Month	Last Year
Days	30	31	33
kW	3	3	9
Daily kWh	0	0	0
Daily Cost \$	0.71	0.68	0.98

Thank you for your payment of \$21.33 received on 06/03/2002

* kWh Charge is a minimum charge

Continued on next page
When paying in person, please bring bottom portion of this bill.



Post Office Box 2907
Phoenix, AZ 85062-2907

TONTO HILLS UTILITY CO
Your Account Number
Billing Date

038012289
Aug 14, 2002

Questions? Visit our website at www.aps.com or
call 602-371-6767, 24 hours a day, 7 days a week.
Para servicio en español llame al 602-371-6861.

Previous Balance as of 07/29/2002	Payments Received	Current Charges	Total Due by 08/27/2002
114.11	114.11 cr	144.99	144.99

Weather can
increase your
energy use and
your APS bill.

This July was one
of the hottest on
record!

SERVICE INFORMATION

Service number 4751S90289
Your service plan E-221 Rate
Service address 42841 N LA Plata Rd

Your meter number 778116
Your meter is read in cycle 09

On Aug 12 your total kWh read was 85672
On Jul 12 your total kWh read was 84229
Your total kWh usage is 1443

Your kW demand read was 11

CURRENT CHARGES

Basic service charge	15.00
Charge for kWh used	101.78
Charge for kW demand	18.15
ACC mandated environmental surcharge	1.26
Regulatory assessment	0.21
Sales tax	8.59
Total current charges	144.99

ENERGY USE COMPARISON			
	This Month	Last Month	Last Year
Days	31	30	32
kW	11	11	0
Daily kWh	46	33	0
Daily Cost \$	4.67	3.80	0.49

Thank you for your payment of \$114.11 received on 08/06/2002

#2797

Continued on next page
When paying in person, please bring bottom portion of this bill.



Post Office Box 2907
Phoenix, AZ 85062-2907

TONTO HILLS UTILITY CO
Your Account Number
Billing Date

336960288
Aug 14, 2002

Questions? Visit our website at www.aps.com or
call 602-371-6767, 24 hours a day, 7 days a week.
Para servicio en español llame al 602-371-6861.

Previous Balance as of 07/16/2002	Payments Received	Current Charges	Total Due by 08/27/2002
264.45	264.45 cr	317.16	317.16

Weather can
increase your
energy use and
your APS bill.

This July was one
of the hottest on
record!

SERVICE INFORMATION

Service number 0603S30288
Your service plan E-221 Rate
Service address 11950 E Blue Wash Rd
Well 4

Your meter number 557639
Your meter is read in cycle 09

On Aug 12 your total kWh read was 3796
On Jul 12 your total kWh read was 99692
Your total kWh usage is 4104

Your kW demand read was 10

CURRENT CHARGES

Basic service charge 15.00
Charge for kWh used 262.80
Charge for kW demand 16.50
ACC mandated environmental surcharge 3.59
Regulatory assessment 0.47
Sales tax 18.80
Total current charges 317.16

ENERGY USE COMPARISON			
	This Month	Last Month	Last Year
Days	31	30	32
kW	10	10	10
Daily kWh	132	105	0
Daily Cost \$	10.23	8.81	1.05

Thank you for your payment of \$264.45 received on 08/06/2002

Continued on next page
When paying in person, please bring bottom portion of this bill.



Post Office Box 2907
Phoenix, AZ 85062-2907

TONTO HILLS UTILITY CO
Your Account Number
Billing Date

336960288
Sep 13, 2002

Questions? Visit our website at www.aps.com or
call 602-371-6767, 24 hours a day, 7 days a week.
Para servicio en español llame al 602-371-6861.

Previous Balance as of 08/14/2002	Payments Received	Current Charges	Total Due by 09/26/2002
317.16	317.16 cr	288.86	288.86

**CAREFREE PAY
STATION CLOSES**

Answer to Your
Business Needs will
stop accepting APS
payments as of
September 19, 2002.
You have several
convenient payment
options - pay your
bill online at
aps.com, make your
payment using the
IVR phone system
(602-371-7171 or
1-800-253-9405), or
visit our office at
4612 East Bell
Road.

SERVICE INFORMATION

Service number 0603S30288
Your service plan E-221 Rate
Service address 11950 E Blue Wash Rd
Well 4

Your meter number 557639
Your meter is read in cycle 09

On Sep 11 your total kWh read was 7413
On Aug 12 your total kWh read was 3796
Your total kWh usage is 3617

Your kW demand read was 10

CURRENT CHARGES

Basic service charge 15.00
Charge for kWh used 236.65
Charge for kW demand 16.50
ACC mandated environmental surcharge 3.16
Regulatory assessment 0.43
Sales tax 17.12
Total current charges 288.86

ENERGY USE COMPARISON			
	This Month	Last Month	Last Year
Days	30	31	29
kW	10	10	8
Daily kWh	120	132	6
Daily Cost \$	9.62	10.23	1.73

Thank you for your payment of \$317.16 received on 08/27/2002

*#2824
418.90
10/3/02*

Continued on next page
When paying in person, please bring bottom portion of this bill.



Post Office Box 2907
Phoenix, AZ 85062-2907

TONTO HILLS UTILITY CO
Your Account Number 038012289
Billing Date Sep 13, 2002

Questions? Visit our website at www.aps.com or
call 802-371-6767, 24 hours a day, 7 days a week.
Para servicio en español llame al 602-371-6881.

Previous Balance as of 08/14/2002	Payments Received	Current Charges	Total Due by 09/26/2002
144.99	144.99 cr	130.04	130.04

**CAREFREE PAY
STATION CLOSES**

Answer to Your
Business Needs will
stop accepting APS
payments as of
September 19, 2002.
You have several
convenient payment
options - pay your
bill online at
aps.com, make your
payment using the
IVR phone system
(602-371-7171 or
1-800-253-9405), or
visit our office at
4612 East Bell
Road.

SERVICE INFORMATION

Service number 4751S90289
Your service plan E-221 Rate
Service address 42841 N LA Plata Rd

Your meter number 778116
Your meter is read in cycle 09

On Sep 11 your total kWh read was 86903
On Aug 12 your total kWh read was 85672
Your total kWh usage is 1231
Your kW demand read was 11

CURRENT CHARGES

Basic service charge 15.00
Charge for kWh used 87.91
Charge for kW demand 18.15
ACC mandated environmental surcharge 1.08
Regulatory assessment 0.19
Sales tax 7.71
Total current charges 130.04

ENERGY USE COMPARISON

	This Month	Last Month	Last Year
Days	30	31	29
kW	11	11	1
Daily kWh	41	46	0
Daily Cost \$	4.33	4.67	0.63

Thank you for your payment of \$144.99 received on 08/27/2002

Continued on next page
When paying in person, please bring bottom portion of this bill.



Post Office Box 2907
Phoenix, AZ 85062-2907

TONTO HILLS UTILITY CO
Your Account Number
Billing Date

336960288
Oct 15, 2002

Questions? Visit our website at www.aps.com or
call 802-371-8767, 24 hours a day, 7 days a week.
Para servicio en español llame al 802-371-8861.

Previous Balance as of 09/13/2002	Payments Received	Current Charges	Total Due by 10/28/2002
288.86	288.86 cr	374.46	374.46

SERVICE INFORMATION

Service number 0603S30288
Your service plan E-221 Rate
Service address 11950 E Blue Wash Rd
Well 4

Your meter number 557639
Your meter is read in cycle 09

On Oct 11 your total kWh read was 12503
On Sep 11 your total kWh read was 7413
Your total kWh usage is 5090

Your kW demand read was 10

CURRENT CHARGES

Basic service charge 15.00
Charge for kWh used 315.76
Charge for kW demand 16.50
ACC mandated environmental surcharge 4.45
Regulatory assessment 0.55
Sales tax 22.20
Total current charges 374.46

ENERGY USE COMPARISON			
	This Month	Last Month	Last Year
Days	30	30	29
kW	10	10	10
Daily kWh	169	120	22
Daily Cost \$	12.48	9.62	3.04

Thank you for your payment of \$288.86 received on 10/08/2002

*OK PD 10/30/02
2887*

Continued on next page
When paying in person, please bring bottom portion of this bill.



Post Office Box 2907
Phoenix, AZ 85062-2907

TONTO HILLS UTILITY CO
Your Account Number
Billing Date

038012289
Oct 15, 2002

Questions? Visit our website at www.aps.com or
call 602-371-6767, 24 hours a day, 7 days a week.
Para servicio en español llame al 602-371-6861.

Previous Balance as of 09/13/2002	Payments Received	Current Charges	Total Due by 10/28/2002
130.04	130.04 cr	147.19	147.19

SERVICE INFORMATION

Service number 475TS90289
Your service plan E-221 Rate
Service address 42841 N LA Plata Rd

Your meter number 778116
Your meter is read in cycle 09

On Oct 11 your total kWh read was 88402
On Sep 11 your total kWh read was 86903
Your total kWh usage is 1499

Your kW demand read was 10

CURRENT CHARGES

Basic service charge 15.00
Charge for kWh used 105.44
Charge for kW demand 16.50
ACC mandated environmental surcharge 1.31
Regulatory assessment 0.22
Sales tax 8.72
Total current charges 147.19

ENERGY USE COMPARISON			
	This Month	Last Month	Last Year
Days	30	30	29
kW	10	11	1
Daily kWh	49	41	0
Daily Cost \$	4.90	4.33	0.67

Thank you for your payment of \$130.04 received on 10/08/2002

*RD 10/30/02
CK 2837*

Continued on next page
When paying in person, please bring bottom portion of this bill.



Post Office Box 2907
Phoenix, AZ 85062-2907

TONTO HILLS UTILITY CO
Your Account Number
Billing Date

038012289
Nov 14, 2002

Questions? Visit our website at www.aps.com or
call 602-371-6767, 24 hours a day, 7 days a week.
Para servicio en español llame al 602-371-6881.

Previous Balance as of 10/15/2002	Payments Received	Current Charges	Total Due by 11/27/2002
147.19	147.19 cr	155.51	155.51

SERVICE INFORMATION

Service number 4751S90289
Your service plan E-221 Rate
Service address 42841 N LA Plata Rd

*11/25
OK 2855*

Your meter number 778116
Your meter is read in cycle 09

On Nov 12 your total kWh read was 90019
On Oct 11 your total kWh read was 88402
Your total kWh usage is 1617

Your kW demand read was 10

CURRENT CHARGES

Basic service charge 15.00
Charge for kWh used 113.16
Charge for kW demand 16.50
ACC mandated environmental surcharge 1.41
Regulatory assessment 0.23
Sales tax 9.21
Total current charges 155.51

ENERGY USE COMPARISON			
	This Month	Last Month	Last Year
Days	32	30	29
kW	10	10	2
Daily kWh	50	49	1
Daily Cost \$	4.85	4.90	0.82

Thank you for your payment of \$147.19 received on 10/31/2002

Continued on next page
When paying in person, please bring bottom portion of this bill.



Post Office Box 2907
Phoenix, AZ 85062-2907

TONTO HILLS UTILITY CO
Your Account Number
Billing Date

336960288
Nov 14, 2002

Questions? Visit our website at www.aps.com or
call 602-371-8767, 24 hours a day, 7 days a week.
Para servicio en español llame al 602-371-8861.

Previous Balance as of 10/15/2002	Payments Received	Current Charges	Total Due by 11/27/2002
374.46	374.46 cr	404.97	404.97

SERVICE INFORMATION

Service number 0603S30288
Your service plan E-221 Rate
Service address 11950 E Blue Wash Rd
Well 4

Your meter number 557639
Your meter is read in cycle 09

On Nov 12 your total kWh read was 18118
On Oct 11 your total kWh read was 12503
Your total kWh usage is 5615

Your kW demand read was 10

CURRENT CHARGES

Basic service charge 15.00
Charge for kWh used 343.96
Charge for kW demand 16.50
ACC mandated environmental surcharge 4.91
Regulatory assessment 0.60
Sales tax 24.00
Total current charges 404.97

ENERGY USE COMPARISON			
	This Month	Last Month	Last Year
Days	32	30	29
kW	10	10	10
Daily kWh	175	169	42
Daily Cost \$	12.65	12.48	4.45

Thank you for your payment of \$374.46 received on 10/31/2002

Continued on next page
When paying in person, please bring bottom portion of this bill.

SECTION

8

SECTION 8.0

SECTION 8

**INVOICES FOR REPAIRS AND MAINTENENCE DURING
THE TEST YEAR (Acct. 620)**

TYPE	DATE	NUMBER	NAME	MEMO	AMOUNT
CHECK	9/19/02	2806	CULLIGAN		\$1,628.71
CHECK	1/30/02	2680	AZ Blue Stake	N/A	\$10.36
CHECK	6/12/02	2757	AZ Blue Stake		\$64.10
				N/A..NOT AVAILABLE	
				TOTAL	\$74.46
CHECK	1/30/02	2678	Frederick L.	N/A	\$328.88
CHECK	3/27/02	2711	Don Unthank	N/A	\$32.31
CHECK	8/5/02	2766	COSTCO		\$52.65
CHECK	6/30/02	2776	Frederick L.		\$26.37
CHECK	9/14/02	2805	Home Depot	N/A	\$182.71
CHECK	9/30/02	2820	Frederick L.		\$31.60
CHECK	11/25/02	2852	Home Depot	N/A	\$361.46
CHECK	12/31/02	2881	Frederick L.		\$25.72
				N/A..NOT AVAILABLE	
				TOTAL	\$1,041.70
				TOTAL	\$2,744.87

054081782280

Culligan®

PO BOX 1604
MINNEAPOLIS MN 55440-1604

^{71 3}
INVOICE
081960

Phone: 602-264-3111

ACCT #	8759847
BILLING DATE	8/31/02
DLR	291
AMOUNT	1,628.71
DUE DATE	

SERVICE ADDRESS
TONTTO HILLS UTILITY
11431 E MANANA
CAVE CREEK AZ 85331

TONTTO HILLS UTILITY
11431 E MANANA
CAVE CREEK AZ 85331-2873



CULLIGAN WATER
PO BOX 1604
MINNEAPOLIS MN 55440-1604



291 8759847 8/31/02 1,628.71

DETACH UPPER PORTION AND RETURN WITH PAYMENT

			INVOICE NUMBER
			081960
DATE	DESCRIPTION OF TRANSACTION	REFERENCE	CURRENT AMOUNTS
8/28	30 SERVICE CALL	88971	1,023.93
8/30	30 SERVICE CALL	90118	604.78
SEND INQUIRIES TO:			
		BILLING DATE	ACCOUNT NO.
		8/31/02	8759847
		DUE DATE	TOTAL DUE
			1,628.71

DETACH UPPER PORTION AND RETURN WITH PAYMENT

			PREVIOUS BALANCE
			.00
DATE	DESCRIPTION OF TRANSACTION	REFERENCE	CURRENT AMOUNTS
8/31	INVOICE # 081960 THANK YOU FOR YOUR PROMPT PAYMENT.		1628.71
<i>CR # 2806</i> <i>9/19/02</i>			

COSTCO WHOLESALE
WAREHOUSE #427

BUSINESS MEMBER #321616783110

*** NOTHING ON BOTTOM of First Basket

331386 HP C6578AN 48.89

*** 7.70% TAX RATE 3.76

2766 TOTAL 52.65

Check/Member Pmt 52.65

CASH .00

TOTAL NUMBER OF ITEMS SOLD = 1

CASHIER: ETTY S. REG#14
8/05/2002 17:53 0427 14 0269 182

Online Shopping WWW.COSTCO.COM
Member Service 1-800-774-2678
Thank You!

*Color
Cartridge
E Ink Printer*

STATEMENT

From Lou FREDERICK

19

To TRUC *[Signature]*

Address *[Signature]*

City *[Signature]*

Terms

8/20/02	RAT POISON	4	94
9/5/02	3/4" PVC & VALVES	15	52
7/30/02	RAT POISON	4	95
7/30/02	BUG REPELLENT	6	21
		31	60

[Large handwritten mark]

STATEMENT

From LOU F

7/1/02

To TRUC *[Signature]*

Address *[Signature]*

City *[Signature]*

Terms

4/10	STOPWATCH BATTERY	2	78*
2/27	GAS FOR JEEP	9	45
4/25	" " "	13	93
		TAX *	21
			26.16
			226.371

[Large handwritten mark]

SECTION

9

SECTION 9.0

**SECTION 9
INVOICES FOR OUTSIDE SERVICES DURING
THE TEST YEAR (Acct. 630)**

TYPE	DATE	NUMBER	NAME	MEMO	AMOUNT
CHECK	3/4/02	2700	WET, INC.		\$1,763.63
CHECK	6/3/02	2736	WET, INC.		\$540.00
					\$2,303.63

CHECK	4/6/02	2667	RON SHIELDS		\$290.00
CHECK	6/19/02	2760	RON SHIELDS		\$790.00
CHECK	8/30/02	2795	RON SHIELDS	N/A	\$85.00
CHECK	9/29/02	2807	RON SHIELDS		\$840.00
CHECK	11/22/02	2848	RON SHIELDS	N/A	\$1,500.00
CHECK	12/16/02	2854	RON SHIELDS	N/A	\$2,000.00
N/A--NOT AVAILABLE					\$5,505.00

CHECK	2/22/02	2689	Cody Bayuk	Meter Reader	\$69.00
CHECK	2/28/02	2695	Cody Bayuk	Meter Reader	\$69.00
CHECK	3/31/02	2715	Cody Bayuk	Meter Reader	\$69.00
CHECK	4/30/02	2741	Cody Bayuk	Meter Reader	\$69.00
CHECK	5/30/02	2755	Cody Bayuk	Meter Reader	\$69.00
CHECK	6/30/02	2777	Cody Bayuk	Meter Reader	\$69.00
CHECK	7/31/02	2854	Cody Bayuk	Meter Reader	\$69.00
CHECK	8/31/02	2812	Cody Bayuk	Meter Reader	\$69.00
CHECK	9/30/02	2823	Cody Bayuk	Meter Reader	\$69.00
CHECK	10/31/02	2838	Cody Bayuk	Meter Reader	\$69.00
CHECK	11/30/02	2864	Cody Bayuk	Meter Reader	\$69.00
CHECK	12/31/02	2877	Cody Bayuk	Meter Reader	\$69.00
Meter Reader..Paid Monthly				TOTAL	\$828.00

CHECK	5/31/02	2756	Tom Ophais	Operator	\$20.00
CHECK	10/31/02	2839	Tom Ophais	Operator	\$53.33
Operator Backup..Paid from Fax				TOTAL	\$73.33

CHECK	8/28/02	2794	NEOTECH		\$262.50
-------	---------	------	---------	--	----------

SECTION 9 (Continued)
INVOICES FOR OUTSIDE SERVICES DURING
THE TEST YEAR (Acct. 630)

TYPE	DATE	NUMBER	NAME	MEMO	AMOUNT
CHECK	1/22/02	2672	Hustead Engineering		\$400.00
CHECK	5/15/02	2745	Hustead Engineering		\$2,100.00
CHECK	7/24/02	2783	Hustead Engineering		\$1,300.00
					\$3,800.00

CHECK	1/7/02	2664	Foothills Accounting	Checks Written	\$600.00
CHECK	2/9/02	2685	Foothills Accounting	Checks Written	\$600.00
CHECK	2/19/02	2687	Foothills Accounting	Checks Written	\$650.00
CHECK	3/16/02	2702	Foothills Accounting	Checks Written	\$600.00
CHECK	4/15/02	2720	Foothills Accounting	Checks Written	\$600.00
CHECK	5/9/02	2743	Foothills Accounting	Checks Written	\$600.00
CHECK	6/12/02	2758	Foothills Accounting	Checks Written	\$600.00
CHECK	7/12/02	2778	Foothills Accounting	Checks Written	\$600.00
CHECK	8/16/02	2791	Foothills Accounting	Checks Written	\$600.00
CHECK	9/17/02	2813	Foothills Accounting	Checks Written	\$600.00
CHECK	10/11/02	2825	Foothills Accounting	Checks Written	\$600.00
CHECK	11/6/02	2844	Foothills Accounting	Checks Written	\$600.00
CHECK	12/9/02	2866	Foothills Accounting	Checks Written	\$600.00
Checks Written When Financial Statements Prepared				TOTAL	\$7,850.00

CHECK	10/25/02	2828	Henry L., Howe		\$437.50	
CHECK	11/27/02	2856	Henry L., Howe		\$793.30	
CHECK	12/30/02	2872	Henry L., Howe		\$54.30	
					TOTAL	\$1,285.10

TOTAL	\$21,907.56
--------------	--------------------

WET INC.

Western Environmental Technologies
P.O. Box 4752
Cave Creek, Arizona 85327

INVOICE

Invoice Number: 200821
Invoice Date: 02/01/02
Page: 1

Sold to: Tonto Hills Water Company
11431 East Manana
Cave Creek, Arizona 85331

Cust. ID: THPWS
Due Date: 03/02/02
Terms: Net 30 days

Contract #:
Invoice #:

Service Description

Service Charge 10/01/01 - 01/31/02	540.00
12 hours county correspondence, micro biological sampling plan, blending plan @ \$40.00 per hour	480.00
Purchase: Arizona Republic 443.63, County Review fees 300.00	743.63

#2700
3/4/02

Total Due: 1,763.63

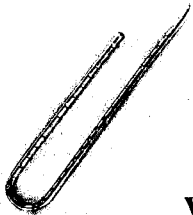

WET INC.

Western Environmental Technologies
P.O. Box 4752
Cave Creek, Arizona 85327

INVOICE

Invoice Number: 200822
Invoice Date: 06/01/02
Page: 1

Sold to: Tonto Hills Water Company
11431 East Manana
Cave Creek, Arizona 85331

Cust. ID: THPWS
Due Date: 07/02/02
Terms: Net 30 days

Contract #:
Invoice #:

Service Description	
Service Charge 2/01/02 - 05/31/02	540.00
<i>Chc 2736</i> <i>6-3-02</i>	
Total Due: \$540.00	

224318

STATEMENT

DATE 4-1-02

TERMS

TO Tonto Hills Utility Co.
 ADDRESS 11431 Marana Rd
 Tonto Hills Az. 85331
 IN ACCOUNT WITH 623-516-9701
 RCA SHIELDS
 P.O. Box 165
 Cave Creek, Az. 85327

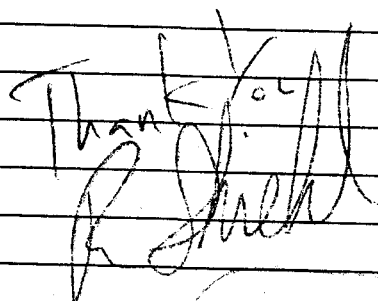
	Installed two new meters on 2" PVC main line from Scottsdale			
	Pipe & fittings		\$30.00	
	5 hr. Labor		\$260.00	
			\$290.00	
<p>Thank You  R. Shields</p>				
<p>ck 2667 4-6-02</p>				

224340

STATEMENT

DATE

6-19-02

TERMS

TO Tonto Hills Utility Co.

ADDRESS 11431 Marana

Cave Creek Az. 85331

IN ACCOUNT WITH 623-516-9701

RCN SHIELDS

P.O. Box 165

Cave Creek Az. 85327

	Loosened + shut off broken			
	water service, installed			
	temporary line from main to meter			
9	hr. Labor Plumber helper		\$595.00	
6-21-02	Installed new water service			
	from main line to meter +			
	backfilled			
	Deer tr. Rd. N. of Kachina Rd			
3	hr. Labor Plumber helper		\$195.00	
			\$790.00	
<p>Thank You R Shields</p>				<p>ok # 2760</p>

424266

STATEMENT

DATE 9-18-02

TERMS

TO Tonto Hills Utility Co
 ADDRESS 11431 Mauana Rd
 Tonto Hills Az. 85331

IN ACCOUNT WITH 623-516-9701
 RICH SHIELDS
 PO. Box 165
 Cave Creek AZ 85327

chk # 2807
 9/29/02

		Installed pressure pump for water treatment system		
9-18-02	2	hr Labor Helper		\$30.00
	6	hr Labor Plumber		\$300.00
	1	1/2" Back flow Valve		\$45.00
	1	1 1/2" PVC Ball Valve-Union		\$25.00
		PVC Pipe + F. Hngs		\$10.00
9-19-02		Installed check valve on outlet of pump		
	3	hr. Labor		\$150.00
9-20-02		Installed spring loaded check valve		
	3	hr. Labor		\$150.00
		Check valve + fittings		\$30.00
9-26-02		Reinstalled check valve on inlet end of pump		
	2	hr. Labor		\$100.00
		Thank you R. Shields		\$840.00

NEOTECH

COMPUTER SPECIALISTS
FOR ARIZONA AND THE WEST

MULTIPLE USE FORM

Date In 8/28/02
 Customer Tonto Hills Utility Co
 Address _____
 City/State/Zip _____
 Telephone 480 488 9389

- INSTALLATION REPAIR UPGRADE
 OTHER _____

Equipment _____
 Accessories included _____
 Description of problem _____

Estimated Cost _____
 Deposit PAID _____ Check Number _____

Neotech is not responsible for loss of data while performing a repair or installation. Customers are encouraged to back-up hard disk drive data prior to service. Neotech warrants only those items which are installed or repaired in whole by Neotech. Neotech is not responsible for loss of business while repair or service is conducted. All new materials installed by Neotech are warranted for one year from date of installation. After initial installation, labor is free-of-charge for one year for new products installed by Neotech only. TERMS: A 50% Deposit is required for all products and services, balance due on delivery. Repaired items left thirty (30) days after notification of completion may be subject to sale in order to cover repair costs.
TROUBLESHOOTING FEE: \$50.00 This charge is to determine the actual problem and to recommend repair options.

Customer Signature X

SERVICE NOTES Clean up Desktop
Remove some old programs
Reset label & letter
settings on Access

Service Description

QTY/HRS	DESCRIPTION	PRICE
3.5 hr @ 75		262.50
Service SUBTOTAL		262.50

Materials Description

Materials SUBTOTAL		
Tax		
Total		262.50

*Thanks
Jewell*
 Date Out 8/28/02

Paid / Received By X
 Balance PAID 262.50 Check Number 2794

For Information Please Call
(480) 488-2917

Hustead Engineering

568 W. Moon Valley Drive
Phoenix, Arizona 85023

(602) 993-9924

INVOICE

Tonto Hills Water Company
11802 E. Blue Wash Road
Cave Creek, AZ. 85331

January 16, 2002

Engineering services 1/14/02 to 1/16/02 for review of data and preparation of certification for blending plan for MCESD.

1. Review of Data	2 hr
2. Edit of Plan Report	1 hr
3. Filing of Certification	1 hr

TOTAL	4 hr

FEE

Engineer 4 hr X \$ 100/hr = \$ 400

2672
1-22-02

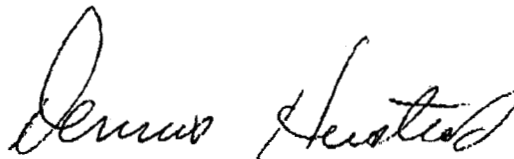

Dennis Hustead, P.E.
Hustead Engineering

Hustead Engineering

568 W. Moon Valley Drive
Phoenix, Arizona 85023

(602) 993-9924

INVOICE

Tonto Hills Water Company
11802 E. Blue Wash Road
Cave Creek, AZ. 85331

May 7, 2002

Engineering services to 5/7/02 for review of AN West Pump Station modification plans and cost estimate for negotiation of cost sharing purposes between Tonto Hills W.C and Desert Mountain.

1. Review of AN West plans (Preliminary)	4 hr
2. Review of AN West plans (Final)	2 hr
3. Review/Analyze AN West cost estimate and allocation	4 hr
4. Prepare Tonto Hills cost estimate and allocation	8 hr
5. Prepare report for Tonto Hills	3 hr

TOTAL	21 hr

FEE

Engineer 21 hr X \$ 100/hr = \$ 2,100

*pd #2745
5/15/02*



Dennis Hustead, P.E.
Hustead Engineering

Hustead Engineering**568 W. Moon Valley Drive
Phoenix, Arizona 85023**

(602) 993-9924

INVOICETonto Hills Water Company
11802 E. Blue Wash Road
Cave Creek, AZ. 85331

July 8, 2002

Attn: Don Unthank

Engineering services to July 8, 2002 for Review of final AN West plans and bid solicitation for pump station modifications at Pump Station # 94, at Desert Mountain.

1. Meeting with AN West and Tonto Hills	2 hr
2. Plan Review w/ Contractors	
Gilbert Pump	4 hr
Flowtech Pump	4 hr
3. Review of Bids/ Modify Cost Allocation	3 hr

TOTAL HOURS	13 hr

Fee Calculation

Engineer 13 hr X \$ 100/hr = \$ 1,300

Amount Due This Invoice \$ 1,300

Dennis Hustead, P.E.
Hustead EngineeringPd 7/24/02
ck 2783

STATEMENT
 HARRY L. HOWE, P.C.
 10505 North 69th Street
 Suite 101
 Scottsdale, AZ 85253
 FED. TAX ID NO. 86-0423567
 Telephone: (480) 948-0940

Mr. Don Unthank
 c/o VALLEY LIGHT GALLERY
 7125 East Mercer Lane
 Scottsdale, AZ 85254

October 17, 2002

Re: Desert Mountain Contract

Professional services

	<u>Hrs/Rate</u>	<u>Amount</u>
10/14/02 HLH Telephone conference with Don Unthank regarding Desert Mountain contract	0.10 175.00/hr	17.50
HLH Begin review of Desert Mountain contract	1.00 175.00/hr	175.00
10/15/02 HLH Complete review of Desert Mountain contract	1.00 175.00/hr	175.00
HLH Telephone conference with Andy Bell regarding Plaintiff's reapplication to corporation commission for relief	0.40 175.00/hr	70.00
For professional services rendered	<u>2.50</u>	<u>\$437.50</u>
Previous balance		\$1,359.10
9/10/02 Payment - thank you		(\$1,359.10)
Balance due		<u><u>\$437.50</u></u>

*Pd 10/30/02
chk 2828*

STATEMENT
HARRY L. HOWE, P.C.
 10505 North 69th Street
 Suite 101
 Scottsdale, AZ 85253
 FED. TAX ID NO. 86-0423567
 Telephone: (480) 948-0940

Mr. Don Unthank
 c/o VALLEY LIGHT GALLERY
 7125 East Mercer Lane
 Scottsdale, AZ 85254

November 15, 2002

*Pl 1127-02
 CK #2856*

Re: Desert Mountain Contract

Professional services

	<u>Hrs/Rate</u>	<u>Amount</u>
10/16/02 HLH Office conference with Don regarding Desert Mountain contract	1.30 175.00/hr	227.50
HLH Prepare letter to Jim Ekins of Desert Mountain with contract changes	1.00 175.00/hr	175.00
HLH Telephone conference with Jim Ekins regarding proposed contract changes	0.20 175.00/hr	35.00
10/18/02 HLH Telephone call to Jim Ekins, left message to call	0.10 175.00/hr	NO CHARGE
10/22/02 HLH Telephone conference with Jim Ekins regarding contract changes	0.20 175.00/hr	35.00
HLH Telephone conference with Don regarding telephone conference with Jim Ekins	0.10 175.00/hr	17.50

Mr. Don Unthank

Page 2

	<u>Hrs/Rate</u>	<u>Amount</u>
10/22/02 HLH Return telephone call to Andy Marshall regarding contract details	0.30 175.00/hr	52.50
10/23/02 HLH Review 10/22/02 letter from Jim Ekins and Amended Agreement	0.70 175.00/hr	122.50
HLH Prepare letter to Jim Ekins regarding revising paragraph 8 of agreement	0.20 175.00/hr	35.00
10/29/02 HLH Review 10/28/02 letter from Jim Ekins with revised Agreement	0.20 175.00/hr	35.00
HLH Telephone conference with Don regarding revised Agreement	0.10 175.00/hr	17.50
HLH Prepare letter to Don regarding signing revised Agreement	0.10 175.00/hr	17.50
HLH Prepare letter to Rich Yehling, Chief Financial Officer of Desert Mountain, regarding executed agreement	0.10 175.00/hr	17.50
For professional services rendered	4.60	\$787.50
Additional charges:		
	<u>Qty/Price</u>	
11/15/02 Xerox copies	29 0.20	5.80
Total costs		\$5.80
Total amount of this bill		\$793.30
Previous balance		\$437.50

STATEMENT
 HARRY L. HOWE, P.C.
 10505 North 69th Street
 Suite 101
 Scottsdale, AZ 85253
 FED. TAX ID NO. 86-0423567
 Telephone: (480) 948-0940

Mr. Don Unthank
 c/o VALLEY LIGHT GALLERY
 7125 East Mercer Lane
 Scottsdale, AZ 85254

December 17, 2002

Re: Desert Mountain Contract

Professional services

	<u>Hrs/Rate</u>	<u>Amount</u>
11/26/02 HLH Review fully executed Agreement and wiring instructions	0.10 175.00/hr	17.50
HLH Prepare letter to Don regarding \$50,000 deposit	0.20 175.00/hr	35.00
For professional services rendered	0.30	\$52.50
Additional charges:		

	<u>Qty/Price</u>	
12/13/02 Xerox copies	9 0.20	1.80

Total costs \$1.80

Total amount of this bill \$54.30

Previous balance \$793.30

AD 12-30-02
 CK 2872

SECTION

10

SECTION 10.0

Company Name: Tonto Hills Utility Company	Test Year Ended: December 31, 2002
--	---------------------------------------

SECTION 10

**INVOICES FOR WATER TESTING DURING
THE TEST YEAR (Acct. 635)**

ARIZONA DEPARTMENT OF ENVIRONMENTAL QUALITY

TYPE	DATE	NUMBER	NAME	MEMO	AMOUNT
CHECK	12/24/02	2859	AZ DEPT OF ENVIRONM		\$471.49
N/A--NOT AVAILABLE				TOTAL	\$471.49

LEGEND TECH

CHECK	1/14/02	2669	LEGEND TECH	N/A	\$15.00
CHECK	1/31/02	2681	LEGEND TECH		\$15.00
CHECK	2/28/02	2696	LEGEND TECH		\$15.00
CHECK	3/25/02	2704	LEGEND TECH		\$15.00
CHECK	4/29/02	2734	LEGEND TECH	N/A	\$15.00
CHECK	5/30/02	2749	LEGEND TECH		\$15.00
CHECK	6/27/02	2769	LEGEND TECH		\$15.00
CHECK	9/3/02	2804	LEGEND TECH	N/A	\$805.00
CHECK	9/25/02	2816	LEGEND TECH		\$845.00
CHECK	10/30/02	2829	LEGEND TECH	N/A	\$405.00
CHECK	10/18/02	2830	LEGEND TECH		\$15.00
CHECK	11/19/02	2850	LEGEND TECH		\$15.00
CHECK	12/9/02	2868	LEGEND TECH		\$15.00
N/A--NOT AVAILABLE				TOTAL	\$2,205.00
TOTAL OF ALL					\$2,676.49



**ARIZONA DEPARTMENT OF ENVIRONMENTAL QUALITY
MONITORING ASSISTANCE PROGRAM
ANNUAL SAMPLING FEE INVOICE**

* Pursuant to A.R.S. § 49-113, interest will be charged if full payment is not received by the specified due date. If you dispute the amount listed, please contact ADEQ as soon as possible. To reduce interest costs on an unpaid invoice, you may remit an amount that you believe is not in dispute. However, if nonpayment is due to wilful neglect, you may suffer an additional five percent penalty of up to twenty-five percent of the amount due for each month or fraction of a month the amount is past due.

If you have any questions about your invoice, contact
W. Scott Steinhagen at (602) 771-4445
or toll-free within Arizona at (800) 234-5677, extension 4445

Pursuant to A.R.S. § 49-360 F and A.A.C. R18-4-224 through R18-4-226, "The director shall establish fees for the monitoring assistance program to be collected from all public water systems..."

Account/PWSID #: 7076	Invoice Number 59712
To: TONTO HILLS UTILITY CO 11802 E BLUE WASH RD CAVE CREEK, AZ 85331 	<i>Pd 12-402</i> <i>CR 2859</i>
	Billing for Calendar Year: 2003
	Due Date: December 16, 2002
	Total Amount Due \$ 471.49
	Amount Paid \$

↑ Keep the top portion for your records. ↑

ADEQ Federal Tax #866004791

LEGEND

INVOICE

INVOICE DATE	INVOICE NO	PAGE
1/09/02	081634	1

Technical Services of Arizona, Inc.

Legend Technical Services of Arizona
17631 N. 25th Avenue • Phoenix, Arizona 85023
(602) 942-8220 • fax (602) 942-1050

SOLD TO Tonto Hills Utility Co.
11431 E. Manana Road
Cave Creek, AZ 85331

SHIP TO Tonto Hills Utility Co.
11802 E. Blue Wash Road
Cave Creek, AZ 85331

Attn: Dave Reimers

Attn: Donald Unthank

TOTAL DUE 15.00

CLIENT NO	REFERENCE NO	PURCHASE ORDER NO	TERMS
099847	0201-00149		NET 30 DAYS

tem#	Description	Qty	Unit	Unit-Price	Ext-price
M 9223	Colilert	1	EACH	15.00	15.00

#2681

WE ACCEPT VISA or MASTERCARD



SALE TOTAL	15.00
INVOICE TOTAL DEPOSIT	
BALANCE DUE	15.00

LEGEND

Technical Services of Arizona, Inc.

Legend Technical Services of Arizona
17631 N. 25th Avenue • Phoenix, Arizona 85023
(602) 942-8220 • fax (602) 942-1050

INVOICE

INVOICE DATE	INVOICE NO	PAGE
2/13/02	082628	1

SOLD TO

Tonto Hills Utility Co.
11431 E. Manana Road
Cave Creek, AZ 85331

Attn: Dave Reimers

SHIP TO

Tonto Hills Utility Co.
11802 E. Blue Wash Road
Cave Creek, AZ 85331

Attn: Donald Unthank

TOTAL DUE

15.00

CLIENT NO	REFERENCE NO	PURCHASE ORDER NO	TERMS
099847	0202-01213		NET 30 DAYS

tem#	Description	Qty	Unit	Unit-Price	Ext-price
M 9223	Colilert	1	EACH	15.00	15.00

2696
2/4/02

WE ACCEPT VISA or MASTERCARD



SALE TOTAL	15.00
INVOICE TOTAL DEPOSIT	
BALANCE DUE	15.00

INVOICE

LEGEND

INVOICE DATE	INVOICE NO.	PAGE
3/13/02	083498	1

Technical Services of Arizona, Inc.

Legend Technical Services of Arizona
17631 N. 25th Avenue • Phoenix, Arizona 85023
(602) 942-8220 • fax (602) 942-1050

SOLD TO
Tonto Hills Utility Co.
11431 E. Manana Road
Cave Creek, AZ 85331

SHIP TO
Tonto Hills Utility Co.
11802 E. Blue Wash Road
Cave Creek, AZ 85331

Attn: Dave Reimers

Attn: Donald Unthank

TOTAL DUE 15.00

CLIENT NO.	REFERENCE NO.	PURCHASE ORDER NO.	TERMS
099847	0203-01986		NET 30 DAYS

tem#	Description	Qty	Unit	Unit-Price	Ext-price
M 9223	Colilert	1	EACH	15.00	15.00

*ck # 2704
3/25/02*

WE ACCEPT VISA or MASTERCARD



SALE TOTAL	15.00
INVOICE TOTAL DEPOSIT	
BALANCE DUE	15.00

LEGEND

Technical Services of Arizona, Inc.

Legend Technical Services of Arizona
17631 N. 25th Avenue • Phoenix, Arizona 85023
(602) 942-8220 • fax (602) 942-1050

INVOICE

INVOICE DATE	INVOICE NO.	PAGE
4/10/02	084385	1

SOLD TO Tonto Hills Utility Co.
11431 E. Manana Road
Cave Creek, AZ 85331

Attn: Dave Reimers

SHIP TO Tonto Hills Utility Co.
11802 E. Blue Wash Road
Cave Creek, AZ 85331

Attn: Donald Unthank

TOTAL DUE 15.00

CLIENT NO.	REFERENCE NO.	PURCHASE ORDER NO.	TERMS
099847	0204-02913		NET 30 DAYS

Item#	Description	Qty	Unit	Unit-Price	Ext-price
SM 9223	Colilert	1	EACH	15.00	15.00

*Per CR 2734
4/29/02*

WE ACCEPT VISA or MASTERCARD



SALE TOTAL	15.00
INVOICE TOTAL DEPOSIT	
BALANCE DUE	15.00

INVOICE

INVOICE DATE	INVOICE NO	PAGE
5/15/02	085382	1

LEGEND

Technical Services of Arizona, Inc.

Legend Technical Services of Arizona
17631 N. 25th Avenue • Phoenix, Arizona 85023
(602) 942-8220 • fax (602) 942-1050

OLD
O Tonto Hills Utility Co.
11431 E. Manana Road
Cave Creek, AZ 85331

Attn: Dave Reimers

SHIP TO Tonto Hills Utility Co.
11802 E. Blue Wash Road
Cave Creek, AZ 85331

Attn: Donald Unthank

TOTAL DUE 15.00

CLIENT NO.	REFERENCE NO.	PURCHASE ORDER NO.	TERMS
099847	0205-03918		NET 30 DAYS

tem#	Description	Qty	Unit	Unit-Price	Ext-price
M 9223	Colilert	1	EACH	15.00	15.00

CR # 2749-5/30

WE ACCEPT VISA or MASTERCARD



SALE TOTAL	15.00
INVOICE TOTAL DEPOSIT	
BALANCE DUE	15.00

INVOICE

LEGEND

Technical Services of Arizona, Inc.

Legend Technical Services of Arizona
17631 N. 25th Avenue • Phoenix, Arizona 85023
(602) 942-8220 • fax (602) 942-1050

INVOICE DATE	INVOICE NO.	PAGE
6/12/02	086171	1

SOLD TO
Tonto Hills Utility Co.
11431 E. Manana Road
Cave Creek, AZ 85331

Attn: Dave Reimers

SHIP TO
Tonto Hills Utility Co.
11802 E. Blue Wash Road
Cave Creek, AZ 85331

Attn: Donald Unthank

TOTAL DUE 15.00

CLIENT NO.	REFERENCE NO.	PURCHASE ORDER NO.	TERMS
099847	0206-04774		NET 30 DAYS

tem#	Description	Qty	Unit	Unit-Price	Ext-price
M 9223	Colilert	1	EACH	15.00	15.00

#2769
6/27/02

WE ACCEPT VISA or MASTERCARD



SALE TOTAL	15.00
INVOICE TOTAL DEPOSIT	
BALANCE DUE	15.00

INVOICE

LEGEND

INVOICE DATE	INVOICE NO.	PAGE
9/12/02	088959	1

Technical Services of Arizona, Inc.

17631 N. 25th Avenue • Phoenix, Arizona 85023
 (602) 324-6100 • fax (602) 324-6101

OLD Tonto Hills Utility Co.
 11431 E. Manana Road
 Cave Creek, AZ 85331

SHIP Tonto Hills Utility Co.
 TO 11802 E. Blue Wash Road
 Cave Creek, AZ 85331

Attn: Dave Reimers

Attn: Donald Unthank

TOTAL DUE

845.00

CLIENT NO.	REFERENCE NO.	PURCHASE ORDER NO.	TERMS
099847	0208-07105		NET 30 DAYS

Item#	Description	Qty	Unit	Unit-Price	Ext-price
PA 903.1	Radium 226	3	EACH	80.00	240.00
PA 904	Radium 228	2	EACH	110.00	220.00
PA 600/00-02	Gross Alpha, Adjusted	3	EACH	55.00	165.00
0-PRECIP.	Gross Alpha	2	EACH	0.00	0.00
F 0-07	Uranium	2	EACH	110.00	220.00

2816
 9/25/02

WE ACCEPT VISA or MASTERCARD



SALE TOTAL	845.00
INVOICE TOTAL DEPOSIT	
BALANCE DUE	845.00

INVOICE

INVOICE DATE	INVOICE NO.	PAGE
9/30/02	089477	1

LEGEND

Technical Services of Arizona, Inc.

17631 N. 25th Avenue • Phoenix, Arizona 85023
(602) 324-6100 • fax (602) 324-6101

Tonto Hills Utility Co.
11431 E. Manana Road
Cave Creek, AZ 85331

Attn: Dave Reimers

Tonto Hills Utility Co.
SHIP TO 11802 E. Blue Wash Road
Cave Creek, AZ 85331

Attn: Donald Unthank

TOTAL DUE

15.00

CLIENT NO.	REFERENCE NO.	PURCHASE ORDER NO.	TERMS
099847	0209-08113		NET 30 DAYS

Item#	Description	Qty	Unit	Unit-Price	Ext-price
SM 9223	Colilert	1	EACH	15.00	15.00

*Pd Chk 2830
10-18-02*

WE ACCEPT VISA or MASTERCARD



SALE TOTAL	15.00
INVOICE TOTAL DEPOSIT	
BALANCE DUE	15.00

CLIENT NO	REFERENCE NO	PURCHASE ORDER NO	TERMS
099847	0210-09164		NET 30 DAYS

Item#	Description	Qty	Unit	Unit-Price	Ext-price
23	Colilert	1	EACH	15.00	15.00

Inv 105-49

*11-19-02
chk 2850*

WE ACCEPT VISA or MASTERCARD



SALE TOTAL	15.00
INVOICE TOTAL DEPOSIT	
BALANCE DUE	15.00

LEGEND

Technical Services of Arizona, Inc.

17631 N. 25th Avenue • Phoenix, Arizona 85023
(602) 324-6100 • fax (602) 324-6101

INVOICE

INVOICE DATE	INVOICE NO.	PAGE
11/27/02	091380	1

SOLD TO Tonto Hills Utility Co.
11431 E. Manana Road
Cave Creek, AZ 85331

Attn: Dave Reimers

SHIP TO Tonto Hills Utility Co.
11802 E. Blue Wash Road
Cave Creek, AZ 85331

Attn: Donald Unthank

TOTAL DUE

15.00

QUANTITY	REFERENCE NO.	PURCHASE ORDER NO.	TERMS
099847	0211-10020		NET 30 DAYS

Item#	Description	Qty	Unit	Unit-Price	Ext-price
SM 9223	Colilert	1	EACH	15.00	15.00

*PD 12-10-02
#2868*

WE ACCEPT VISA or MASTERCARD



SALE TOTAL	15.00
INVOICE TOTAL DEPOSIT	
BALANCE DUE	15.00

SECTION

11

SECTION 11.0

Company Name: Tonto Hills Utility Company	Test Year Ended: December 31, 2002
--	---------------------------------------

SECTION 11

**STATEMENTS FROM COUNTY FOR PROPERTY TAXES DURING
THE TEST YEAR (Acct. 408.3)**

TYPE	DATE	NUMBER	NAME	MEMO	AMOUNT
CHECK	3/25/02	2706	MARICOPA CTY	2ND HALF	\$1,828.80
CHECK	3/25/02	2707	MARICOPA CTY	2ND HALF	\$341.49
CHECK	3/25/02	2708	MARICOPA CTY	2ND HALF	\$9.10
CHECK	6/27/02	2770	MARICOPA CTY	21912115	\$28.27
CHECK	6/27/02	2771	MARICOPA CTY	21912115	\$5.05
CHECK	10/18/20	2831	MARICOPA CTY	62739300	\$1,978.48
CHECK	10/18/02	2832	MARICOPA CTY--N/A	21912115	\$280.90
N/A--NOT AVAILABLE					\$4,472.09

PROPERTY DESCRIPTION
 SEC/LOT TWN/BLK RNG/TR
 TOTAL VALUE OF OPERATING PROPERTY

**MARICOPA COUNTY
 TREASURER**

DOUG TODD, TREASURER
 301 W JEFFERSON ST - RM 100
 PHOENIX, AZ 85003-2199
 /treasurer.maricopa.gov
 NUMBERS ON OTHER SIDE

**MARICOPA COUNTY
 2001 PROPERTY TAX
 STATEMENT**

NOTICE: SEE REVERSE SIDE FOR
 IMPORTANT INFORMATION.

\$25.00 CHARGE IF CHECK
 FAILS TO CLEAR BANK.

YOUR CHECK IS YOUR RECEIPT.

TONTO HILLS UTILITY CO
 11802 E BLUE WASH RD
 CAVE CREEK AZ 85331

*1st half
 # 2683
 11/2/01*

LIMITED (PRIMARY) VALUES				PRIMARY	COMPARATIVE 2000 AMT	2001 DISTRIBUTION		OFFICE USE ONLY
TYPE	LIMITED	%	ASSESSED			RATE / 100	2001 AMT DUE	
LAND/BLDG PERSONAL EXEMPTION	1980 178920	25.0	495 44230	COUNTY EDUC. EQUAL CITY SCHOOL CO. EDUC COMM. COL.	490.85 216.07 1491.00 408.72	11832 04974 31254 9583	529.16 222.49 1397.83 428.60	PRTKEY= SEQ= 3434 MTG= LOAN#= W -
PRIM. TOT.	178900		44725					
AREA CODE 930000				SUBTOTAL	2606.74	57643	2578.08	FIRST HALF TAX AMOUNT 1,828.80
FULL CASH (SECONDARY) VALUES				SECONDARY				SECOND HALF TAX AMOUNT 1,828.80
TYPE	FULL CASH	%	ASSESSED					
LAND/BLDG PERSONAL EXEMPTION	1980 178920	25.0	495 44230	FLOOD CAWCD OVERRIDES FIRE DIST. ASST. LIBRARY *BONDS** -COUNTY -CITY -SCHOOLS -COMM COL.	1.22 54.82 93.32 4.04 17.76 48.59 843.50 63.39 1126.64	2319 1300 1376 0091 0421 0876 18524 1524 26431	1.14 58.14 61.54 4.06 18.82 39.18 828.48 68.16 1078.52	DUE OCT. 1, 2001 DELINQUENT AFTER NOV. 1, 2001
SEC. TOT.	178900		44725	SUBTOTAL				DUE MARCH 1, 2002 DELINQUENT AFTER MAY 1, 2002
SPECIAL DISTRICT (VALUE/ACRES/SQ.FT) ASSESSED				DIST#				INTEREST ON LATE PAYMENT IS 16% PER YEAR PRORATED MONTHLY AS OF THE FIRST DAY OF THE MONTH. ARS 42-18053
IF NOT PAID BY DELINQUENT DATES, CALL OR WRITE FOR INTEREST AMOUNT.					3733.38	TOTALS	\$3,657.60	KEEP THIS PORTION FOR YOUR RECORDS

*2nd Half # 2706
 3/25/02*

In accordance with the Americans with Disabilities Act, the County Treasurer will provide materials in alternative formats and will make other reasonable accommodations upon request.

PARCEL#219-12-228E 9

MARICOPA COUNTY TREASURER

DOUG TODD, TREASURER
301 W JEFFERSON ST - RM 100
PHOENIX, AZ 85003-2199
//treasurer.maricopa.gov
NUMBERS ON OTHER SIDE

**DELINQUENT BACK
TAXES ARE OWED
ON THIS PARCEL**
CALL OR WRITE FOR AMOUNT

PROPERTY DESCRIPTION
SEC/LOT TWN/BLK RNG/TR E
TONTON HILLS MCR 93/5 PT TR 5 & ALSO ABND R/W PER
FEE 87-574421 EX FROM ABOVE DESC PROP ANY PT LY
WT/IN PER FEE 90-280022

MARICOPA COUNTY 2001 PROPERTY TAX STATEMENT

NOTICE: SEE REVERSE SIDE FOR
IMPORTANT INFORMATION.
\$25.00 CHARGE IF CHECK
FAILS TO CLEAR BANK.
YOUR CHECK IS YOUR RECEIPT.

*****AUTOCR**H-007
TONTON HILLS UTILITY COMPANY # 2042
11802 E BLUE WASH RD 11/2/01
CAVE CREEK AZ 85331-2841



LIMITED (PRIMARY) VALUES				PRIMARY	COMPARATIVE 2000 AMT	2001 DISTRIBUTION		OFFICE USE ONLY	
TYPE	LIMITED	%	ASSESSED			RATE / 100	2001 AMT DUE		
AND/BLDG PERSONAL EXEMPTION	86005	10.0	8601	COUNTY	145.62	11832	101.76	PRTKEY=85331 SEQ=383996 MTG= LOAN#= R -	
				EDUC. EQUAL	64.10	04974	42.79		
				CITY					
				SCHOOL	442.27	31254	268.81		
				CO. EDUC					
				COMM. COL.	121.23	9583	82.42		
PRIM. TOT.	86005		8601	STATE AID		CREDIT	-94.08		
AREA CODE 930000				SUBTOTAL	773.22	57643	401.70		FIRST HALF TAX AMOUNT 341.49
FULL CASH (SECONDARY) VALUES				SECONDARY					DUE OCT. 1, 2001 DELINQUENT AFTER NOV. 1, 2001
AND/BLDG PERSONAL EXEMPTION	106417	10.0	10642	FLOOD	43.14	2319	24.68		SECOND HALF TAX AMOUNT 341.49 DUE MARCH 1, 2002 DELINQUENT AFTER MAY 1, 2002
				CAWCD	22.14	1300	13.84		
				OVERRIDES	37.68	1376	14.64		
				FIRE DIST. ASST.	1.64	0091	.96		
				LIBRARY	7.16	0421	4.48		
				*BONDS**					
				-COUNTY	19.61	0876	9.32		
				-CITY					
				-SCHOOLS	340.53	18524	197.14		
				-COMM COL.	25.59	1524	16.22		
SEC. TOT.	106417		10642	SUBTOTAL	497.50	26431	281.28	INTEREST ON LATE PAYMENT IS 16% PER YEAR PRORATED MONTHLY AS OF THE FIRST DAY OF THE MONTH. ARS 42-18053	
SPECIAL DISTRICT (VALUE/ACRES/SQ. FT) ASSESSED				DIST#				KEEP THIS PORTION FOR YOUR RECORDS	
IF NOT PAID BY DELINQUENT DATES, CALL OR WRITE FOR INTEREST AMOUNT					1270.72	TOTALS	\$682.98		

*2nd Half #2707
3/28*

accordance with the Americans with Disabilities Act, the County Treasurer will provide materials in alternative formats and
will make other reasonable accommodations upon request.

PARCEL# 219 12 228E 9

PLEASE PRINT THE PARCEL NUMBER ON YOUR CHECK OR MONEY ORDER.

ANY QUESTIONS CONCERNING YOUR DELINQUENT TAXES PLEASE CONTACT (602)506-8511

MARICOPA COUNTY TREASURER NOTICE OF PAST DUE TAXES 2000 PROPERTY TAX YEAR

(BILLED IN OCT. 2000 WITH FIRST HALF DUE OCT. 1, 2000 AND SECOND HALF DUE MAR. 1, 2001)

DOUG TODD TREASURER 301 W JEFFERSON HOENIX, AZ 85003-2199 (602)506-8511 http://treasurer.maricopa.gov

TONTO HILLS UTILITY CO 11802 E BLUE WASH RD CAVE CREEK AZ 85331

PROPERTY DESCRIPTION

SEC/LOT TWN/BLK RNG/TR E

TONTO HILLS MCR 93/5 PT TR 5 & ALSO ABND R/W PER FEE 87-574421 EX FROM ABOVE DESC PROP ANY PT LY WI/IN PER FEE 90-280022

FOR OFFICE USE ONLY

1 X

UP# 2708-3/25

IMPORTANT - PUBLIC NOTICE IS HEREBY GIVEN that I will offer at public sale at the Office of the Treasurer of Maricopa County, Arizona, commencing on

FEBRUARY 4, 2002,

On the succeeding days, a tax lien on the above described real property, upon which there are delinquent taxes, for an amount necessary to pay the taxes with interest, penalties and charges thereon, with: ARS 42-18108.

ADDITIONAL INTEREST WILL ACCRUE AT THE RATE OF 16.00% PER ANNUM CALCULATED MONTHLY IF NOT PAID BY THE DATE SHOWN AT RIGHT

Table with columns: YEAR, ASSESSED VALUE, PARCEL NUMBER, IF PAID BY, TAXES, INTEREST, TOTAL DUE. Includes data for 2000 and monthly breakdown from June to November.

Please confirm legal description prior to payment on any property. The Treasurer's office is not responsible for payment on wrong parcel numbers.

Checks do not pay taxes. Legal payment exists only when checks have cleared Banks. Checks returned UNPAID by Bank may be subject to a collection fee.

Make payment by check or money order in U.S. dollars drawn on U.S. banks only.

In accordance with A.R.S. 42-18107B on tax liens, an Advertising Fee of \$5.00 or 5%, whichever is greater, is required on payments after December 31.

(58,838*PRTCNTL) TAXPAYER'S STATEMENT, KEEP TOP PORTION FOR YOUR RECORDS

PLEASE PRINT THE PARCEL NUMBER ON YOUR CHECK OR MONEY ORDER.

ANY QUESTIONS CONCERNING YOUR DELINQUENT TAXES PLEASE CONTACT (602)506-8511

MARICOPA COUNTY TREASURER NOTICE OF PAST DUE TAXES 2001 PROPERTY TAX YEAR

(BILLED IN OCT. 2001 WITH FIRST HALF DUE OCT. 1, 2001 AND SECOND HALF DUE MAR. 1, 2002)

DOUG TODD
TREASURER
301 W JEFFERSON
PHOENIX, AZ 85003-2199
(602)506-8511
http://treasurer.maricopa.gov

TONTO HILLS UTILITY CO
11802 E BLUE WASH RD
CAVE CREEK AZ 85331

2770
6/27/02

PROPERTY DESCRIPTION

SEC/LOT TWN/BLK RNG/TR

TOTAL VALUE OF OPERATING PROPERTY

DELINQUENT BACK TAXES ARE OWED ON THIS PARCEL
CALL OR WRITE FOR AMOUNT

FOR OFFICE USE ONLY

IMPORTANT → PUBLIC NOTICE IS HEREBY GIVEN that I will offer at public sale at the Office of the Treasurer of Maricopa County, Arizona, commencing on

FEBRUARY 10, 2003,

ir succeeding days, a tax lien on the above real property, upon which there are delinquent taxes, for an amount necessary to pay the taxes with interest, penalties and charges thereon, to wit: ARS 42-18108.

ADDITIONAL INTEREST WILL ACCRUE AT THE RATE OF 16.00% PER ANNUM CALCULATED MONTHLY IF NOT PAID BY THE DATE SHOWN AT RIGHT

YEAR	ASSESSED VALUE		PARCEL NUMBER
PARTIAL 2001	PRIMARY: 44,725	SECONDARY: 44,725	627 39 300 7
IF PAID BY	TAXES	INTEREST	TOTAL DUE
JUNE 30	27.54	.73	\$28.27
JULY 31	27.54	1.10	\$28.64
AUG. 31	27.54	1.47	\$29.01
SEP. 30	27.54	1.84	\$29.38
OCT. 31	27.54	2.20	\$29.74
NOV. 30	27.54	2.57	\$30.11

Please confirm legal description prior to payment on any property. The Treasurer's office is not responsible for payment on wrong parcel numbers.

Checks do not pay taxes. Legal payment exists only when checks have cleared Banks. Checks returned UNPAID by Bank may be subject to a collection fee.

Make payment by check or money order in U.S. dollars drawn on U.S. banks only.

In accordance with A.R.S. 42-18107B on tax liens, an Advertising Fee of \$5.00 or 5%, whichever is greater, is required on payments after December 31.

(492-PATCNTL)

TAXPAYER'S STATEMENT, KEEP TOP PORTION FOR YOUR RECORDS

PLEASE PRINT THE PARCEL NUMBER ON YOUR CHECK OR MONEY ORDER.

DOUG TODD
 TREASURER
 301 W JEFFERSON
 PHOENIX, AZ 85003-2199
 (602)506-8511
 http://treasurer.maricopa.gov

**MARICOPA COUNTY TREASURER
 NOTICE OF PAST DUE TAXES
 2001 PROPERTY TAX YEAR**

(BILLED IN OCT. 2001 WITH FIRST HALF DUE OCT. 1, 2001 AND SECOND HALF DUE MAR. 1, 2002)

ANY QUESTIONS CONCERNING YOUR DELINQUENT TAXES PLEASE CONTACT (602)506-8511

TONTO HILLS UTILITY COMPANY
 11802 E BLUE WASH RD
 CAVE CREEK AZ 85331

#2771
 6/27/02

PROPERTY DESCRIPTION

SEC/LOT TWN/BLK RNG/TR E

TONTO HILLS MCR 93/5 PT TR 5 & ALSO ABND R/W PER FEE 87-574421 EX FROM ABOVE DESC PROP ANY PT LY WI/IN PER FEE 90-280022

FOR OFFICE USE ONLY
1 X

IMPORTANT → PUBLIC NOTICE IS HEREBY GIVEN that I will offer at public sale at the Office of the Treasurer of Maricopa County, Arizona, commencing on **FEBRUARY 10, 2003,** following days, a tax lien on the above described real property, upon which there are delinquent taxes, for an amount necessary to pay the taxes with interest, penalties and charges thereon. Authority: ARS 42-18108.

ADDITIONAL INTEREST WILL ACCRUE AT THE RATE OF 16.00% PER ANNUM CALCULATED MONTHLY IF NOT PAID BY THE DATE SHOWN AT RIGHT

YEAR	ASSESSED VALUE		PARCEL NUMBER
PARTIAL 2001	PRIMARY: 8,601	SECONDARY: 10,642	219 12 228E 9
IF PAID BY	TAXES	INTEREST	TOTAL DUE
JUNE 30	4.92	.13	\$5.05
JULY 31	4.92	.20	\$5.12
AUG. 31	4.92	.26	\$5.18
SEP. 30	4.92	.33	\$5.25
OCT. 31	4.92	.39	\$5.31
NOV. 30	4.92	.46	\$5.38

Please confirm legal description prior to payment on any property. The Treasurer's office is not responsible for payment on wrong parcel numbers.

Checks do not pay taxes. Legal payment exists only when checks have cleared Banks. Checks returned UNPAID by Bank may be subject to a collection fee.

Make payment by check or money order in U.S. dollars drawn on U.S. banks only.

In accordance with A.R.S. 42-18107B on tax liens, an Advertising Fee of \$5.00 or 5%, whichever is greater, is required on payments after December 31.

(61,504-PRICNTL) TAXPAYER'S STATEMENT, KEEP TOP PORTION FOR YOUR RECORDS

MARICOPA COUNTY TREASURER

DOUG TODD, TREASURER
301 W JEFFERSON ST - RM 100
PHOENIX, AZ 85003-2199
http://treasurer.maricopa.gov
IC# NUMBERS ON OTHER SIDE

PROPERTY DESCRIPTION
SEC/LOT TWN/BLK RNG/TR
TOTAL VALUE OF OPERATING PROPERTY

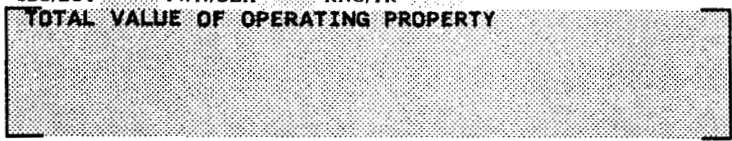

MARICOPA COUNTY 2002 PROPERTY TAX STATEMENT

NOTICE: SEE REVERSE SIDE FOR IMPORTANT INFORMATION.
\$25.00 CHARGE IF CHECK FAILS TO CLEAR BANK.
YOUR CHECK IS YOUR RECEIPT.

TONTO HILLS UTILITY CO
11802 E BLUE WASH RD
CAVE CREEK AZ 85331

LIMITED (PRIMARY) VALUES				PRIMARY	COMPARATIVE 2001 AMT	2002 DISTRIBUTION		OFFICE USE ONLY
TYPE	LIMITED	%	ASSESSED			RATE / 100	2002 AMT DUE	
ND/BLDG	2085	25.0	521	COUNTY	529.19	12108	599.35	PRTKEY= SEQ= 3433 MTG= LOAN#= W -
PERSONAL	195915		48979	EDUC. EQUAL	222.46	04889	242.01	
EMPTION				CITY	1397.83	30796	1524.40	
				SCHOOL	428.60	9634	476.88	
				CO. EDUC				
IM. TOT.	198000		49500	COMM. COL.				
AREA CODE 930000				SUBTOTAL	2578.08	57427	2842.64	FIRST HALF TAX AMOUNT
FULL CASH (SECONDARY) VALUES				SECONDARY				1,978.48
TYPE	FULL CASH	%	ASSESSED	FLOOD	1.14	2119	1.10	DUE OCT. 1, 2002 DELINQUENT AFTER NOV. 1, 2002
ND/BLDG	2085	25.0	521	CAWCD	58.14	1300	64.36	
PERSONAL	195915		48979	OVERRIDES	81.54	2102	104.06	SECOND HALF TAX AMOUNT
EMPTION				FIRE DIST. ASST.	4.06	0076	3.76	
				LIBRARY	18.82	0421	20.84	1,978.48
				*BONDS**				
				-COUNTY	39.18	0800	39.60	DUE MARCH 1, 2003 DELINQUENT AFTER MAY 1, 2003
				-CITY				
				-SCHOOLS	328.48	18297	806.70	INTEREST ON LATE PAYMENT IS 16% PER YEAR PRORATED MONTHLY AS OF THE FIRST DAY OF THE MONTH. ARS 42-18053
				-COMM COL.	68.16	1493	73.90	
C. TOT.	198000		49500	SUBTOTAL	1079.52	24608	1114.32	KEEP THIS PORTION FOR YOUR RECORDS
SPECIAL DISTRICT (VALUE/ACRES/SQ. FT) = ASSESSED				DIST#				
IF NOT PAID BY DELINQUENT DATES, CALL OR WRITE FOR INTEREST AMOUNT.					3657.60	TOTALS	\$3,956.96	

In accordance with the Americans with Disabilities Act, the County Treasurer will provide materials in alternative formats and make other reasonable accommodations upon request.

DETACH AND RETURN WITH PAYMENT



2002 SECOND HALF PAYMENT STUB
DUE MARCH 1, 2003
DELINQUENT AFTER MAY 1, 2003
TO HILLS UTILITY CO

MAKE CHECK PAYABLE TO:
Maricopa County Treasurer
P O Box 78574
Phoenix, AZ 85062-8574

*Check 2831
10-18-02*

PARCEL# 627-39-300 7

PRINT THE ABOVE PARCEL NUMBER ON YOUR CHECK

U.S. FUNDS ONLY

SECOND HALF	\$1,978.48
-------------	------------

MAKE CHANGES TO MAILING ADDRESS BELOW:

SECTION

12

SECTION 12.0

SECTION 12

**STATEMENTS FROM RSC FOR RENTAL EQUIPMENT DURING
THE TEST YEAR (Acct. 641)**

TYPE	DATE	NUMBER	NAME	MEMO	AMOUNT
CHECK	12/30/02	2876	RSC	BACKHOE	\$302.81
CHECK	12/4'02	2857	RSC	BACKHOE	\$1,101.56
					\$1,404.37

RPOPE	RON S.	RON SHEILDS	DENTON, MICHAEL G
JOB PHONE 480-488-3825	CUSTOMER PHONE 480-488-3825	DRIVERS LICENSE NUMBER	ESTIMATED RETURN DATE 12/20/02 9:00 AM

Qty	Unit #	Description	Min	Day	Week	4 Week	AMOUNT
1	276997	BACKHOE-2WD 12-15'	199.00	199.00	834.00	2325.00	199.00
Make: CASE Model: 580SL Ser #: JJG0270877 HR OUT: 2299.80 HR IN: 2305.70 TOTAL: 5.90 Env Fee Rates Dy/Wk/Mo: 2.00/4.00/8.00 CPU EQ# 276997							
1	310-1540	BACKHOE BUCKET-18"	18.00	18.00	63.00	126.00	N/C
SALES ITEMS:							
Qty	Item number	Description	Unit	Price			
15	DSL	DIESEL FUEL FOR EQUIPMENT (OF	EA	3.500	52.50		
1	ERF	ENVIRONMENTAL RECOVERY FEE	EA	2.000	2.00		
				Sub-total:	253.50		
				EZ Assurance:	27.86		
				Tax:	21.45		
				Total:	302.81		

RL 12-30-02
OK 2876

IF THE EQUIPMENT DOES NOT WORK PROPERLY, NOTIFY THE OFFICE AT ONCE MULTIPLE SHIFTS OR OVERTIME RATES MAY APPLY CUSTOMER IS RESPONSIBLE FOR REFUELING, TIRE DAMAGE AND REPAIR

INVOICE #: 14822907-001 CUSTOMER #: 4128320

1. EZ Assurance will be charged absent proof of insurance listing Rental Service Corporation as the loss payee. EZ Assurance is NOT INSURANCE and does not cover upset, overturned, tire or overhead damage or accessory items regardless of fault.
2. Customer must call to release equipment and is responsible for released equipment until it is picked up.
3. Customer is fully responsible for the safekeeping, maintenance, damage to or theft of items rented.

Terms: Payment Due Upon Receipt of Invoice - Delinquency charges, at the maximum monthly rate allowed by law, will apply 30 days from the date of invoice. Collection fees for delinquent accounts, including attorney / collection agency fees and expenses incurred by Rental Service Corporation, are the responsibility of the customer.

S402RNT	RON SHEILD	DENTON, MICHAEL G
JOB PHONE 480-488-3825	CUSTOMER PHONE 480-488-3825	DRIVERS LICENSE NUMBER ESTIMATED RETURN DATE 11/19/02 9:33 AM

Qty	Unit #	Description	Min	Day	Week	4 Week	AMOUNT
1	324224	BACKHOE-2WD 12-15'	199.00	199.00	834.00	2325.00	834.00
Make: CASE Model: 580L Ser #: JJG0304036							
HR OUT: 1462.60 HR IN: 1475.30 TOTAL: 12.70							
Env Fee Rates Dy/Wk/Mo: 2.00/4.00/8.00							
***** RRRRRR TTTTTT DDDDDD *****							
CPU EQ# 324224							
1	310-1560	BACKHOE BUCKET-24"	30.00	30.00	113.00	226.00	N/C
SALES ITEMS:							
Qty	Item number	Description	Unit	Price			
17.5	DSL	DIESEL FUEL FOR EQUIPMENT (OF	EA	3.500	61.25		
1	ERF	ENVIRONMENTAL RECOVERY FEE	EA	4.000	4.00		
					Sub-total:	899.25	
					EZ Assurance:	116.76	
					Tax:	85.55	
					Total:	1101.56	

*pd 12-4-02
ck 2857*

IF THE EQUIPMENT DOES NOT WORK PROPERLY, NOTIFY THE OFFICE AT ONCE MULTIPLE SHIFTS OR OVERTIME RATES MAY APPLY CUSTOMER IS RESPONSIBLE FOR REFUELING, TIRE DAMAGE AND REPAIR

INVOICE #: 14526202-001

CUSTOMER #: 4128320

1. EZ Assurance will be charged absent proof of insurance listing Rental Service Corporation as the loss payee. EZ Assurance is NOT INSURANCE and does not cover upset, overturned, tire or overhead damage or accessory items regardless of fault.
2. Customer must call to release equipment and is responsible for released equipment until it is picked up.
3. Customer is fully responsible for the safekeeping, maintenance, damage to or theft of items rented.

Terms: Payment Due Upon Receipt of Invoice - Delinquency charges, at the maximum monthly rate allowed by law, will apply 30 days from the date of invoice. Collection fees for delinquent accounts, including attorney / collection agency fees and expenses incurred by Rental Service Corporation, are the responsibility of the customer.

SECTION

13

SECTION 13.0

Company Name: Tonto Hills Utility Company	Test Year Ended: December 31, 2002
--	---------------------------------------

SECTION 13

**INVOICES FOR REPAIRS AND MAINTENENCE DURING
THE TEST YEAR (Acct. 618)**

TYPE	DATE	NUMBER	NAME	MEMO	AMOUNT
CHECK	8/15/02	2767	HOME DEPOT	SALT	\$404.63



SPECIAL SERVICES CUSTOMER AGREEMENT
 Store 0472 N SCOTTSDALE
 15499 N HAYDEN RD
 SCOTTSDALE, AZ 85260

Phone: (480) 991-3738
 Salesperson: PWM651
 Reviewer: PWM651

VALIDATION A

SALE 0472 00041 24442 02/15/02
 62 512 03:03 PM

This is only a **QUOTE** for the merchandise and services printed below. This becomes an Agreement upon payment and an endorsement by a Home Depot register validation.

CUSTOMER AGREEMENT # 86646
 RECALL AMOUNT 379.28
 TAX 25.35
 TOTAL \$404.63
 CHECK 404.63
 122105744
 AUTH CODE 911295

SOLD TO Name **TONTO HILLS UTILITY** Home Phone **(480) 488-9389**
 Address **SEE MAP IN FILE** Work Phone () -
 Company Name
 City **PHOENIX** Job Description **COMMSALE**
 State **AZ** Zip **85032** County **MARICOPA**

QUOTE is valid for this date: 08/15/2002

MERCHANDISE AND SERVICE SUMMARY

We reserve the right to limit the quantities of merchandise sold to customers.

HOME DEPOT DELIVERY #1

REF #V02

STOCK MERCHANDISE TO BE DELIVERED:

REF #	SKU	QTY	UM	DESCRIPTION	TAX	PRICE EACH	EXTENSION
R01	208-116	112.00	EA	50LB WATER SOFTNER SALT /	Y	\$2.94	\$329.28
MERCHANDISE TOTAL:							\$329.28

DELIVERY INFORMATION:

SCHEDULED DELIVERY DATE: 08/16/2002

V02	515-663	1.00	EA	Curbside Delivery Service	N	\$50.00	\$50.00
DELIVERY SERVICE SUBTOTAL:							\$50.00

HOME DEPOT WILL DELIVER MDSE TO: TONTO HILLS UTILITY, LOU

CITY: PHOENIX

ADDRESS: SEE MAP IN FILE

STATE: AZ ZIP: 85032 COUNTY: MARICOPA

PHONE: (480) 488-9389

MDSE & DELIVERY TOTALS:

\$379.28

DRIVER SPECIAL INSTRUCTIONS: SEE MAP.

END OF HOME DEPOT DELIVERY - REF #V02

check # 2767



TOTAL CHARGES OF ALL MERCHANDISE & SERVICES

ORDER TOTAL	\$379.28
SALES TAX	\$25.35
TOTAL	\$404.63
BALANCE DUE	\$404.63

END OF ORDER No. 0472-86646

TERMS AND CONDITIONS

DELIVERY TERMS

The Home Depot provides curb service delivery only and is not responsible for property damage beyond curbside delivery. If you assist The Home Depot with any delivery, it will be at your own risk and you hereby release The Home Depot from any claims for loss or damage you may have by reason of your assisting with any delivery. If you require additional delivery service, The Home Depot may assist you; however, any additional delivery service shall be your sole responsibility. The Home Depot is not responsible for any injury to persons or damage to property arising out of The Home Depot's assistance with additional delivery service, and in consideration of such assistance, you release The Home Depot from any claims for loss or damage you may have and shall indemnify and hold The Home Depot harmless from such claims by third parties.

YOU HAVE READ AND ACCEPT ALL OF THE TERMS APPLICABLE TO THE TRANSACTION(S) IN THIS AGREEMENT:

CUSTOMER: _____ DATE: _____
 Signature

APPENDIX C

NON-ACCOUNTED FOR WATER

APPENDIX C

NON-ACCOUNTED FOR WATER

In Decision Number 61109 in FINDINGS OF FACT Number 20 (e) :
"Applicant determine if reducing non-accounted for water to ten percent would be cost effective. When Applicant files its next rate case, it should either reduce non-accounted for water to ten percent or explain why it has not reduced non-accounted for water to ten percent;"

Actions taken to reduce non-accounted for water (Figure 3. Tonto Hills Water Systematic from the Engineers report for Decision Number 61109 is attached for reference purposes):

1. Four new 3/4 inch meters were installed on the discharge piping from the Two Culligan Hi-flo softener units, in order to measure the "backwash" or ejected water discharged to the 4 evaporation basins from the 2 Culligan Hi-flo softener Units which remove the radio chemicals from the water supply,

2. Two new 3/4 inch meters were installed, replacing the existing 3/4 inch meters which measure the water produced by Well Number 4.

3. Two new 3/4 inch meters were installed on existing unmetered services which provide water to a landscaped area (Entryway Meters...Trees) at the entrance to the Tonto Hills Development.

4. A procedure has been established for the Field Supervisor to report Unmetered Water due to Construction, Leaks, and Tank Overflows.

5. A monthly reporting form has been developed (copy attached) to report the Water Purchased, the Well Water Produced, the Backwash Water from the 2 Culligan Hi-flo softeners, the Entryway Meters, Unmetered Water, the Sales to Customers by month, and the calculation of the Non-accounted for water on a monthly and accumulative year to date basis.

The new 3/4 inch meters were installed before September 27, 2003, when all meters were read, including the customers meters. All meters were read again on November 3, 2003. The percent Non-Accounted for water was calculated for the first month following the above changes (September 27 through November 3) and was 7.52%.

The percent Non-Accounted for water was calculated for the second month following the above changes (November 3 through November 29) and was 7.56%. See attached calculation spread sheets.

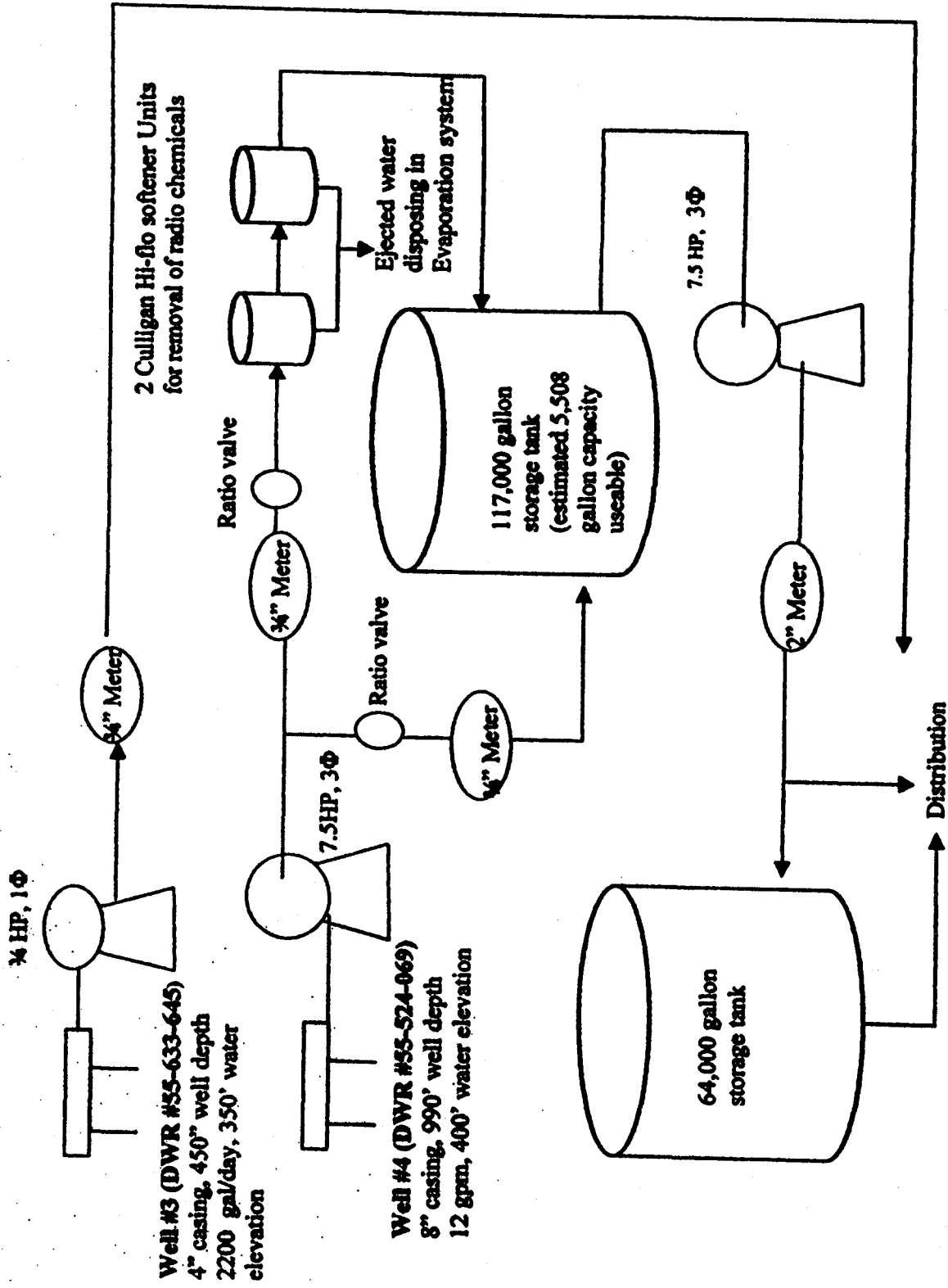

Figure 3. Tonto Hills Water Systematic

**TONTO HILLS UTILITY COMPANY
METER READINGS AND METERED SALES**

DATE METERS READ

METERS AT WELL NO. 4

BACKWASH METERS

4
5
6
7

Meter No

Reading

1	
2	
3	

WELL 4 ELECTRIC METER

PUMP HOUSE ELECTRIC METER

CITY OF SCOTTSDALE METER...CAP WATER

Reading

COS

CAP WATER METERS AT TANK

Reading...METER A

Reading...METER B

ENTRY WAY METER ...TREES

Reading...METER F1

Reading...METER F2

**TOTAL WATER DELIVERED TO CUSTOMERS
THROUGH INDIVIDUAL METERS (SALES)**

For Period:

Date

From:

Total Quantity In Gallons

To:

UNMETERED CONSTRUCTION WATER, LEAKS & TANK OVERFLOW

Total Quantity In Gallons

CONSTRUCTION

LEAKS

TANK OVERFLOW

TONTO HILLS UTILITY COMPANY
WATER PRODUCTION, SALES & LOST WATER
4 th QUARTER....2003

Nov 3	Sept 27	DIFFERENCE	NOV 29	Nov 3	DIFFERENCE	JAN1	NOV 29	DIFFERENCE
	2,600,700	2,127,900	472,800					

CAP Meters at Tank

Meter A	4,050,540	3,818,800	231,740					
Meter B	4,178,130	3,936,620	240,510					
TOTAL CAP METERS AT TANK			472,250					

Difference COS less Tank Meters	550
% Difference	0.12%

WELL # 4

WELL PRODUCTION

Meter 1	387,830	63,880	303,950					
Meter 2	181,530	37,030	144,500					
TOTAL WELL PRODUCTION			448,450					

Meter 3

	68,153,900	67,756,200	395,700					
--	------------	------------	---------	--	--	--	--	--

BACKWASH WATER

Meter 4	10,570	2,110	8,460					
Meter 5	10,370	2,060	8,310					
Meter 6	8,170	2,050	6,120					
Meter 7	7,940	1,980	5,410					

TOTAL BACKWASH WATER			28,300					
BACKWASH WATER AS % OF TOTAL WELL PRODUCTION			6.31%					

TOTAL NET PRODUCTION FROM WELL #4 AND DELIVERED TO SYSTEM

METERS 1 & 2 OF WELL #4 LESS BACKWASH			420,150					
--	--	--	----------------	--	--	--	--	--

TOTAL NET PRODUCTION FROM WELL #4 PLUS CAP WATER

GALLONS	892,950
ACRE FEET	2.74

**TONTO HILLS UTILITY COMPANY
WATER PRODUCTION, SALES & LOST WATER
4 th QUARTER.....2003**

	Nov 3	Sept 27	DIFFERENCE	NOV 29	Nov 3	DIFFERENCE	JAN1	NOV 29	DIFFERENCE
--	-------	---------	------------	--------	-------	------------	------	--------	------------

ENTRYWAY METERS...TREES

Meter F1	7,510	2,930	4,580						
Meter F2	10	10	0						
TOTAL ENTRYWAY ..TREES...WATER			4,580						

UNMETERED WATER

Construction			0						
Leaks			0						
Leaks			0						
Tank Overflow			0						
TOTAL UNMETERED WATER			0						

TOTAL CAP WATER PLUS WELL 4 LESS ENTRYWAY AND UNMETERED

TOTAL PRODUCED AND PURCHASED			886,370						
ACCUMULATIVE YEAR TODATE			886,370						

TOTAL WATER DELIVERED TO CUSTOMERS (Sales)

Through Individual Meters to customers			821,530						
ACRE FEET			2.52						
ACCUMULATIVE YEAR TODATE			821,530						
ACRE FEET			2.52						

UNACCOUNTED FOR WATER

Produced, purchased and delivered less Sales			66,840						
PERCENT OF PRODUCED AND PURCHASED			7.52%						
ACCUMULATIVE YEAR TODATE			66,840						
ACCUMULATIVE YEAR TODATE PERCENT			7.52%						

**TONTO HILLS UTILITY COMPANY
WATER PRODUCTION, SALES & LOST WATER
4 th QUARTER.....2003**

	Nov 3	Sept 27	DIFFERENCE	NOV 29	Nov 3	DIFFERENCE	JAN1	NOV 29	DIFFERENCE
CAP Meter	2,600,700	2,127,900	472,800	3,022,300	2,600,700	421,600			

CAP Meters at Tank

Meter A	4,050,540	3,818,800	231,740	4,256,990	4,050,540	206,450			
Meter B	4,179,190	3,939,620	240,570	4,392,700	4,179,130	213,570			
TOTAL CAP METERS AT TANK			472,250			420,020			

Difference COS less Tank Meters	550					1,580			
% Difference	0.12%					0.37%			

WELL # 4

WELL PRODUCTION

Meter 1	387,830	83,880	303,950	694,050	387,830	306,220			
Meter 2	181,530	37,030	144,500	318,600	181,530	137,070			
TOTAL WELL PRODUCTION			448,450			443,290			
Meter 3	68,153,900	67,758,200	395,700	68,552,600	68,153,900	398,700			

BACKWASH WATER

Meter 4	10,570	2,110	8,460	20,130	10,570	9,580			
Meter 5	10,370	2,060	8,310	19,800	10,370	9,430			
Meter 6	8,170	2,060	6,120	10,670	8,170	2,500			
Meter 7	7,340	1,890	5,450	9,660	7,340	2,320			
TOTAL BACKWASH WATER			26,300			23,810			
BACKWASH WATER AS % OF TOTAL WELL PRODUCTION			6.31%			5.37%			

TOTAL NET PRODUCTION FROM WELL #4 AND DELIVERED TO SYSTEM METERS 1 & 2 OF WELL #4 LESS BACKWASH

			420,150			419,480			
--	--	--	---------	--	--	---------	--	--	--

TOTAL NET PRODUCTION FROM WELL #4 PLUS CAP WATER

GALLONS	841,060
ACRE FEET	2.58

TONTO HILLS UTILITY COMPANY
WATER PRODUCTION, SALES & LOST WATER
4 th QUARTER.....2003

	Nov 3	Sept 27	DIFFERENCE	NOV 29	Nov 3	DIFFERENCE	JAN1	NOV 29	DIFFERENCE
--	-------	---------	------------	--------	-------	------------	------	--------	------------

ENTRYWAY METERS...TREES

Meter F1	7,510	2,930	4,580	12,040	7,510	4,530			
Meter F2	10	10	0	10	10	0			
TOTAL ENTRYWAY...TREES...WATER			4,580			4,530			

UNMETERED WATER

Construction			0			0			
Leaks			0			0			
Leaks			0			0			
Tank Overflow			0			0			
TOTAL UNMETERED WATER			0			0			

TOTAL CAP WATER PLUS WELL 4 LESS ENTRYWAY AND UNMETERED

TOTAL PRODUCED AND PURCHASED			688,370			636,550			
ACCUMULATIVE YEAR TODATE			688,370			1,724,920			

TOTAL WATER DELIVERED TO CUSTOMERS (Sales)

Through Individual Meters to customers			821,530			773,290			
ACUMULATIVE YEAR TODATE			821,530			1,584,820			
		ACRE FEET	2.52			2.37			
		ACRE FEET	2.52			4.89			

UNACCOUNTED FOR WATER

Produced, purchased and delivered less Sales			66,840			63,260			
PERCENT OF PRODUCED AND PURCHASED			7.52%			7.56%			
ACCUMULATIVE YEAR TODATE			66,840			130,100			
ACCUMULATIVE YEAR TODATE PERCENT			7.52%			7.54%			

APPENDIX

D

CITY OF SCOTTSDALE DEVELOPMENT FEE

APPENDIX D



CITY COUNCIL REPORT

MEETING DATE: 03/18/2003 ITEM NO. _____ GOAL: Coordinate Planning to Balance Infrastructure

SUBJECT **Public Hearing for Adjustment of Water, Water Resources and Sewer Development Fees**

REQUEST Conduct a Public Hearing and accept citizen comments on City's intention to adjust Water Development, Water Resources Development and Sewer Development Fees with a construction cost index increase of 2.4% effective July 1, 2003.

BACKGROUND

Development Fees: Development fees are one-time payments that require new development to pay its "proportionate share" of the capital cost of infrastructure capacity needed for growth. These fees apply to all new development. The three Water Resources development fees are: (1) Water Development fees, covering the costs of the potable water system, including water lines, reservoirs, pump stations, new groundwater wells, and treatment facilities; (2) Water Resources Development fees, paying to acquiring water supplies, such as CAP Colorado River allocations, and groundwater recharge; and (3) Sewer Development fees, covering the wastewater infrastructure, such as the collection system and treatment facilities.

There are two fee zones (Zone A and Zones B-E). Zone A covers the area generally south of Shea Boulevard and is essentially built out with infrastructure needs related to planned redevelopment. Zones B-E consist of the remaining area of the City, primarily north of Shea Boulevard, where new development will occur requiring new sources of water and major capital infrastructure. Zone boundaries are shown in Figure 1.

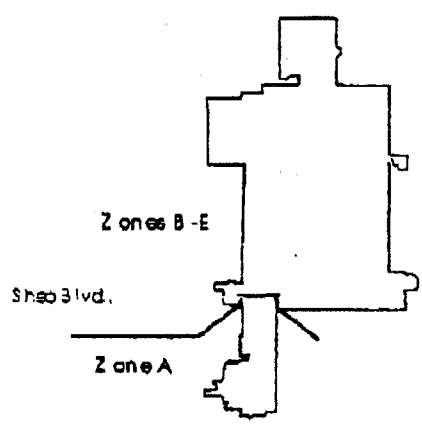

Figure 1: City map with Zone boundaries

Action Taken _____

Water and Sewer development fees are paid at the time of issuance of the building permit and are categorized by use (i.e. single family residential, multi-family residential and non-residential). For single and multi-family residential land use, system demand standards in gallons per day have been established for varying lot sizes. The development fee to be paid is the result of multiplying the average gallons per day of demand times the net capital cost per gallon. For non-residential use, the developer completes an estimated annual water and sewer demand in a Water and Sewer Needs Report and enters into a legal agreement with the City to assure compliance with the estimated demand. This demand is multiplied by the net capital cost per gallon. The usage is monitored and penalties are assessed if estimated usage thresholds are exceeded.

An administrative fee covering processing costs is collected at the time of payment of the total water and sewer development fee. The residential administrative fee is .46 percent of the total water and sewer development fee collected, while the nonresidential administrative fee is 2.04 percent of the total water and sewer development fee collected.

The City contracted with Raftelis Financial Consulting (RFC) in July 2001 to analyze its development fees. RFC concluded the development fee methodology is sound, and the fee calculations are appropriate.

State Public Notification Process: State statutes allow a municipality to assess development fees to offset costs to the municipality associated with providing necessary public services to a development. As part of the adoption process, the statutes require that a municipality release to the public a written report including all documentation that supports the assessment of a new or increased development fee. That report was issued on January 13, 2003. The adoption process also includes requirements for:

- Publication of Notice of Intent to change fees at least 60 days prior to a public hearing (completed Jan. 13, 2003)
- Public hearing at a Council Meeting no sooner than 60 days after Notice of Intent publication (March 18, 2003)
- Adoption of fees no sooner than 14 days after the public hearing (scheduled April 1, 2003)
- Implementation no sooner than 90 days after adoption (July 1, 2003)

The action required at today's meeting is to conduct the public hearing to solicit public comment on the proposed fee adjustment.

Capital Improvements: As part of a "Fiscal Impact of Development Study" prepared by Tischler & Associates, major water and sewer capital improvements required to accommodate new development were identified. Improvement needs have been updated through the Master Plans. These capital improvements and water supply acquisitions are labeled as "system improvements" in contrast to "local improvements" associated within individual subdivisions that are the developer's sole responsibility.

Because of significant costs for future improvements such as the Water Campus, the Tischler study recommended new development fees, which recognized the remaining value of the existing system as well as the estimated cost of the future system, needed to meet projected demand. The Study also recommended different

fees for different planning zones based on distinctive capital improvement needs and growth patterns. The study established the basic fee calculation methodology, which includes:

- Current value of existing facilities
- Cost of future capital facilities for the 15 year base period (currently 2001-2016)
- Cost of new water supplies to meet estimated demands for the base period which meet Arizona Department of Water Resources Assured Water Supply requirements
- Two geographic service areas (Zone A and Zones B-E) with distinct capital and water resource requirements (Figure 1)
- Water and sewer capacity and water resource requirements

Development Fee Update Process: New development fees are implemented on a two-year cycle following an update of the Water Resources Master Plans. In the first year of the cycle, a full fee review is conducted. Estimated future demands and capital costs to provide the required capacity from the Master Plans are revised to account for new or phased construction; fixed assets are updated and revalued to reflect the decline in useful life; base assumptions, including population and employment are reviewed; and the 15-year base period horizon is extended by two years. The new proposed fees are forwarded to City Council in the Comprehensive Biennial Review Report for review and adoption. Following adoption of the 2001 Water Resources Master Plans, the 2002 Development Fee Comprehensive Biennial Review Report was reviewed and approved by the City Council implementing new fees effective July 15, 2002.

In 2003, we are in the second year of the two-year cycle in which the fees are proposed for adjustment by a construction cost index to ensure that the fees continue to recover current construction costs. Utilizing the Engineering News Record construction cost index, a 2.4% increase in the net capital cost per gallon is being proposed. As described in the Water, Water Resources and Sewer Development Fees Construction Cost Adjustment 2003 Report, the 2003 adjusted fees will include all of the system improvements in the 2002 Comprehensive Report and maintain the same base period (2001-2016).

Findings: Expressed in terms of net capital cost per gallon, application of the construction cost index of 2.4% results in the following proposed adjustments:

- Water Development fees
 - \$0.04 increase in Zone A to \$1.52
 - \$0.17 increase in Zones B-E to \$7.34
- Water Resources Development Fees
 - \$0.04 increase in Zone A to \$1.55
 - \$0.05 increase in Zones B-E to \$2.00
- Sewer Development Fees
 - \$0.19 increase in Zone A to \$7.93
 - \$0.57 increase in Zones B-E to \$24.48

ANALYSIS & ASSESSMENT

The City is proposing adjustment of the existing Water Development, Water Resources, and Sewer Development fees utilizing a construction cost index increase of 2.4% for the fiscal year 2003-2004 to ensure that fees are keeping pace with current construction costs. One-time development fee payments help fund construction of public facilities needed to accommodate new development and ensure that new development pays its "proportionate share" of the capital cost of infrastructure capacity needed for growth. These payments decrease the need for funding from other sources. The proposed development fee adjustment has been discussed with the Water Advisory Group (December 2002) with representatives from Valley Partnership, Arizona Multi-housing Association, and Home Builders Association of Central Arizona. In compliance with State law requiring release of a report at least 60 days prior to the noticed public hearing, the Water, Water Resources and Sewer Development Fees Construction Cost Adjustment 2003 Report was posted on January 13, 2003. Tonight's hearing provides an opportunity for citizens to comment on this proposed adjustment.

RESOURCE IMPACTS

The proposed fees are projected to generate revenues of approximately \$14.7 million for fiscal year 2003/04.

OPTIONS & STAFF RECOMMENDATION

Description of Option A:

Conduct public hearing in order to proceed with proposed construction cost index adjustment to fees.

Description of Option B:

Do not conduct public hearing. The fees effective July 15, 2002 will remain in place, and development fee revenues will not maintain current construction cost.

RESPONSIBLE DEPT(S)

Water Resources, Financial Services

STAFF CONTACT(S)

David M. Mansfield, Water Resources General Manager (480)-312-5681. dmansfield@ScottsdaleAz.gov

APPROVED BY

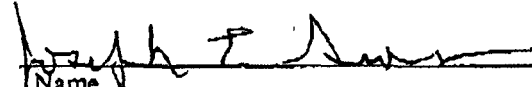
Name: David M. Mansfield, Water Resources General Manager, (480) 312-5681, dmansfield@ScottsdaleAz.gov
Date: 3/3/03

Name: Craig Clifford, Financial Services General Manager, (480) 312-2364, cclifford@ScottsdaleZz.gov
Date: 3/3/03

PLEASE SIGN & DATE

Name: Roger Klingler, Assistant City Manager, (480) 312-5830, rklingler@ScottsdaleAz.gov
Date:

ATTACHMENTS

- 1. Draft - Ordinance No. 3496
- 2. Draft - Exhibit A (Code Update 49-74 and 49-74.3)

Exhibit A

Sec. 49-74. Water and sewer development fees.

- (a) There are hereby imposed water and sewer development fees for the purpose of compensating the city for the cost of system improvements within the city's water and sewer service areas.
- (b) There are hereby established two (2) zones, A and B through E, as reflected on the following map:

GRAPHIC LINK: Water and Sewer Zones

- (1) The boundaries of zone A shall be as follows: that part of the City of Scottsdale which is south of Shea Boulevard, west of Pima Road, and east of Scottsdale Road, including that area south of Indian Bend Road and west of Scottsdale Road which is within the city limits.
- (2) The boundaries of zone B through E shall be as follows: that portion of the City of Scottsdale which is not in zone A and that portion of Maricopa County west of Scottsdale Road, north of Dynamite Boulevard, east of 56th Street, and south of the Carefree Highway.
- (c) The developer shall pay to the city the water and sewer development fees at the time and as a condition of the issuance of a building permit, or if the development does not require a building permit, the fees shall be paid prior to and as a condition of connection to the city's water and/or sewer systems. All funds collected shall be properly identified and promptly transferred for deposit in the appropriate water and sewer development fee accounts.

(d) The amount of the water and sewer development fees shall be determined by the following fee schedules. The developer shall also pay at the time residential water and sewer development fees are paid an administrative fee of forty-six one-hundredths (0.46) percent of the total water and sewer development fee:

TABLE INSET:

Single Family					
Construction Envelope		Zone A		Zones B--E	
(Square feet)		Water	Sewer	Water	Sewer
Minimum	Maximum	System	System	System	System
2,500	3,999	\$ 297.00 \$305.00	\$704.00 \$722.00	\$ 1,281.00 \$ 1,312.00	\$2,176.00 \$2,228.00
4,000	5,499	457.00 470.00	704.00 722.00	1,972.00 2,019.00	2,176.00 2,228.00
5,500	6,999	511.00 524.00	844.00 864.00	2,187.00 2,239.00	2,606.00 2,668.00
7,000	8,499	564.00 579.00	844.00 864.00	2,402.00 2,459.00	2,606.00 2,668.00
8,500	11,799	617.00 634.00	844.00 864.00	2,617.00 2,679.00	2,606.00 2,668.00
11,800	17,299	820.00 861.00	868.00 991.00	3,552.00 3,636.00	2,989.00 3,060.00
17,300	22,799	1,060.00 1,089.00	968.00 991.00	4,486.00 4,592.00	2,989.00 3,060.00
22,800	43,559	1,282.00 1,316.00	1,037.00 1,063.00	5,421.00 5,549.00	3,204.00 3,280.00
43,560	87,119	1,630.00 1,675.00	1,037.00 1,063.00	6,725.00 6,885.00	3,204.00 3,280.00
87,120	130,679	1,878.00 2,033.00	1,068.00 1,094.00	8,030.00 8,221.00	3,300.00 3,378.00
130,680	174,239	2,328.00 2,391.00	1,068.00 1,094.00	9,325.00 9,557.00	3,300.00 3,378.00
174,240	217,799	2,993.00 3,074.00	1,068.00 1,094.00	12,003.00 12,287.00	3,300.00 3378.00
217,800	>>	*	1,068.00 1,094.00	**	3,300.00 3378.00

*\$2,993.00 \$3,074.00 plus \$15.27 \$15.68 per 1,000 square feet over 217,800

~~**\$12,000.00~~ \$12,287.00 plus ~~\$61.24~~ \$62.69 per 1,000 square feet over 217,800

For large single-family residential properties (ten (10) acres or greater) developer may elect to compute and pay water and sewer fees pursuant to the water and sewer fees established for nonresidential uses. Developer shall submit a Water and Sewer Need Report which shall be approved by the city prior to and as a condition of submitting an application for development review board consideration under the Scottsdale Zoning Ordinance, or if no development review board approval is required, prior to submittal of final plans. Penalties for underpayment of such fees, and the administrative fee will be calculated pursuant to the provisions of subparagraph 49-74(e) below.

TABLE INSET:

Multi-Family					
Average Square Feet		Zone A		Zones B-E	
Per Dwelling Unit		Water	Sewer	Water	Sewer
Minimum	Maximum	System	System	System	System
815	1,569	\$310.00 \$318.00	\$704.00 \$722.00	\$1,601.00 \$1,537.00	\$2,176.00 \$2,228.00
1,570	2,339	321.00 330.00	704.00 722.00	1,556.00 1,593.00	2,176.00 2,228.00
2,340	3,109	344.00 353.00	704.00 722.00	1,668.00 1,707.00	2,176.00 2,228.00
3,110	3,869	361.00 371.00	704.00 722.00	1,738.00 1,779.00	2,176.00 2,228.00
3,870	4,639	378.00 388.00	704.00 722.00	1,779.00 1,822.00	2,176.00 2,228.00
4,640	5,399	401.00 411.00	704.00 722.00	1,834.00 1,878.00	2,176.00 2,228.00
5,400	6,169	423.00 435.00	844.00 864.00	1,889.00 1,934.00	2,606.00 2,668.00
6,170	6,939	440.00 452.00	844.00 864.00	1,931.00 1,978.00	2,606.00 2,668.00
6,940	7,899	457.00 469.00	844.00 864.00	1,978.00 2,025.00	2,606.00 2,668.00

7,700	8,469	477.00 490.00	844.00 864.00	2,052.00 2,101.00	2,606.00 2,668.00
8,470	>>	487.00 500.00	844.00 864.00	2,092.00 2,142.00	2,606.00 2,668.00

Nonresidential

Nonresidential water and sewer development fees shall be determined according to the schedule below. Average estimated water usage and sewer generation shall be provided to the city by the developer in a report, which format shall be established by the city, and which Water and Sewer Need Report shall be approved by the city prior to and as a condition of submitting an application for development review board consideration under the Scottsdale Zoning Ordinance, or if no development review board approval is required, prior to submittal of final plans.

TABLE INSET:

Per Gallon of Estimated Average Daily Use	Zone A		Zones B--E	
	Water Development Fee	Sewer Development Fee	Water Development Fee	Sewer Development Fee
All nonresidential	\$1.48 \$1.52	\$7.74* \$7.93*	\$7.17 \$7.34	\$23.91* \$24.48*

*Customers without a sewer connection will not be subject to a sewer development fee.

(e) Penalties for underpayment of nonresidential water and sewer development fees; administrative fee.

(3) Funds from the zone A sewer development fee account may only be used for sewer system improvements which benefit zone A. Funds from the zones B--E sewer development fee account may only be used for sewer system improvements which benefit zones B--E. If a system improvement benefits both zones, funds may be used from each account in proportion to the benefit received by each zone(s).

(j) Periodically, the city manager shall present to the city council a proposed capital improvement program for water and sewer system improvements. Specific water and sewer system improvement projects shall be assigned to each development fee account.

(Ord. No. 2927, § 3, 10-14-96; Ord. No. 3121, § 1, 3-16-98; Ord. No. 3217, § 1, 3-16-99; Ord. No. 3290, § 1, 3-21-00; Ord. No. 3369, § 1, 3-19-01; Ord. No. 3431, § 1(Exh. A), 4-16-02)

Sec. 49-74.3. Water resources development fee.

(a) There is hereby imposed a water resources development fee for the purpose of compensating the city for the costs of acquiring, transporting, treating and managing through recharge to and recovery from underground aquifers, new water resources required by developments within the city's water service area, and is assessed in the amounts stated in the following schedules. The developer shall also pay at the time residential water resources development fees are paid an administrative fee of forty-six one-hundredths (0.46) percent of the total water resources development fee.

Single-Family Residence

TABLE INSET:

Construction Envelope (Square feet)		Zone A Water Resources	Zones B--E Water Resources
Minimum	Maximum	Development Fee	Development Fee
<2,500	3,999	\$ 303.00 \$311.00	\$ 349.00 \$357.00
4,000	5,499	467.00 479.00	536.00 550.00
5,500	6,999	521.00 535.00	586.00 610.00
7,000	8,499	575.00 591.00	653.00 670.00
8,500	11,799	630.00 646.00	712.00 730.00
11,800	17,299	856.00 878.00	956.00 991.00
17,300	22,799	1,082.00 1,110.00	1,220.00 1,251.00
22,800	43,559	1,308.00 1,342.00	1,474.00 1,512.00
43,560	87,119	1,684.00 1,708.00	1,829.00 1,876.00
87,120	130,679	2,019.00 2,073.00	2,184.00 2,240.00
130,680	174,239	2,375.00 2,438.00	2,539.00 2,604.00
174,240	217,799	3,054.00 3,135.00	3,264.00 3,348.00
217,800	>>	*	**

*\$3,054.00 \$3,135.00 plus \$15.59 \$15.99 per 1,000 square feet over 217,800

~~**\$3,264.00~~ \$3,348.00 plus ~~\$16.65~~ \$17.08 per 1,000 square feet over 217,800

For large single-family residential properties (ten (10) acres or greater) developer may elect to compute and pay the water resources development fee pursuant to the water resources development fee established for nonresidential uses. Developer shall submit a Water and Sewer Need Report which shall be approved by the city prior to and as a condition of submitting an application for development review board consideration under the Scottsdale Zoning Ordinance, or if no development review board approval is required, prior to submittal of final plans. Penalties for underpayment of such fee and the administrative fee will be calculated pursuant to the provisions of subparagraph 49-74.3(d) below.

Multi-Family

TABLE INSET:

Average Square Feet		Zone A	Zones B--E
Per Dwelling Unit		Water Resources	Water Resources
Minimum	Maximum	Development Fee	Development Fee
<	1,569	\$316.00 \$324.00	\$408.00 \$419.00
1,570	2,339	328.00 336.00	423.00 434.00
2,340	3,109	351.00 360.00	454.00 465.00
3,110	3,869	368.00 378.00	473.00 485.00
3,870	4,639	386.00 396.00	484.00 496.00
4,640	5,399	409.00 420.00	499.00 512.00
5,400	6,169	432.00 443.00	514.00 527.00
6,170	6,939	449.00 461.00	525.00 539.00
6,940	7,699	466.00	538.00

		478.00	552.00
7,700	8,469	487.00 500.00	558.00 572.00
8,470	>>	487.00 510.00	569.00 584.00

Nonresidential

Nonresidential water resources development fees shall be determined according to the schedule below. Average estimated water usage shall be provided to the city by the developer in a report, which format shall be established by the city, and which report shall be approved by the city prior to and as a condition of submitting an application for development review board consideration under the Scottsdale Zoning Ordinance, or if no development review board approval is required, prior to submittal of final plans.

TABLE INSET:

	Zone A	Zones B--E
Per Gallon of Average Daily Use	Water	Water
	Development Fee	Development Fee
All nonresidential*	\$1.51 \$1.55	\$1.95 \$2.00

*Excluding golf courses.